

	Page nº		Page nº
GROUP 0 - Introduction			
0.1 - Construction. Tubular heating element parts	IV	1.30 - Metallic heating clamps for drums (Models AF)	35
0.2 - EC Conformity statement	IV	1.31 - Flexible silicone heating bands for drums (Models AFBS)	36
0.3 - Quality assurance	IV	(Models AFAFS)	36
0.4 - Electricfor's constructive thermic class	V	(Models AFHSSD)	36
0.5 - Production schedule for shielded tubular elements	VI	1.32 - Insulation jackets for drums (Models AFCHA)	36
GROUP 1 - Immersion heaters, drum heaters and accessories			
1.1 - With coupling plug (Models NA / OV / T)	1	1.33 - Flexible heating blankets for drums (Models AFCCB)	37 - 40
(Models DP / ED / ET)	2 - 3	(Models AFHT)	37
1.2 - Titanium heaters with coupling plug (Modelos TIM)	3	(Models AFHSP)	37
1.3 - Incoloy®-825 heaters with coupling plug (Models NY / OY / DY / EY)	4	1.34 - Base drum heater with adjustable thermostat (Models AFBCB)	38
1.4 - Exchangeables heater elements in stainless steel sheath with 2"1/2 thread (Models RTV)	5	1.35 - 1000 Lts intermediate bulk container heaters. (Models HIBC)	38
1.5 - With coupling plug Europa Range (Models EUROPA RANGE)	6 - 7	1.36 - Immersion heaters for the food industry. (Models EPV-GP)	39
1.6 - Accessories: Aluminium connection box	7	(Models EPV-C2)	39
1.7 - Accessories: Weldable flanges	9	(Models EPV-C1)	40
1.8 - Accessories: Nuts	9	GROUP 2 - Heating elements for air	
1.9 - Accessories: Threaded brass adapters	9	2.1 - Cabinet heaters (Models CAM / HGK)	41
1.10 - Accessories: Gaskets	9 - 10	(Models HG 140 / CSK / CSF)	42
1.1 - Heaters for knife sterilizers (Models ECU)	12	(Models CS / CSL / CR / CS 130)	43
1.12 - With coupling plug and sheath for thermostat (Models NOB)	12 - 13	(Models HV / HVL)	44
1.13 - With round flange and sheath for thermostat (Models PNOB)	13	2.2 - Finned heating elements (Models AL / ALG / ALEC)	46
1.14 - With coupling plug and sheath for thermostat. Suitable for connection box IP-66 (Models NOBxxCH)	13	2.3 - Spiral finned heaters (Models AHR / AHU / AHM)	47
1.15 - Steatite mounted heating elements (Models CT / BT)	14	2.4 - Heating elements with connectors for forced air (Models U)	48
1.16 - Heating elements for electric boilers (Models CALEB)	15	2.5 - Heating elements to make electrical batteries of different dimensions. (Models UST / MxST)	48
1.17 - With connectors (Models 7V / U)	15	2.6 - Electrical batteries with rectangular fin heating elements (Models ALBAT)	49
1.18 - Heating groups with flange (Models GCB)	16 / 22	2.7 - Electrical batteries with spiral fin heating elements (Models AHBAT)	50
1.19 - In line heaters (Models GCP-TR / GCP-TR-INOX)	11	2.8 - Electric batteries for air conditioning (Models BR / BSMC / MNS / ST)	51
(Models GCP)	23	(Models MB / MS / MSR / BTS)	52
1.20 - CAST-IN line heaters	24-25	2.9 - Batteries for cylindrical ducts (Models BMC / BTT)	53
1.21 - Cup type heating elements for fuel-oil or other applications (Models C)	27	2.10 - Electric batteries for air heating (Models TFAN)	54
1.22 - Heating elements with IP44 connection box (Models SBR)	28	(Models TMAX / TMAXL)	55
1.23 - Accessories: Connection box IP-44 with thermostat and limiter (Models CCR)	28	2.11 - Heating elements for ovens and furnaces (Models UTFAN / UTMAX / UTMAXL)	56
1.24 - Circular base heaters (Models SBM / SBC)	29	2.12 - Heating elements for ovens and furnaces (Models M8GRK)	56
1.25 - Heating elements for no aggressive liquids (Models SN / SL / SF)	30	(Models REINF / R / U / Mx360)	57
1.26 - Heating elements for aggressive liquids (Models STI / SIN / SIY)	31	2.13 - Boron Nitrid heaters	58 - 59
(Models SIYMN / STEF)	30	2.14 - Spiral or curved heating elements for ovens	60
1.27 - Heating elements for aggressive liquids (Models RG)	33	2.15 - Braking heating elements for speed variators (Models SAC/PR / SI/PR / RB)	61
1.28 - Flat Teflon heaters for aggressive liquids (Models GVT)	34	GROUP 2A - Heating elements for air and/or immersion	
1.29 - Very low density load heaters (Models CMG)	35	2A.1 - Elementos rectos recocidos en tubo de acero inoxidable (Modelos RR)	62
		2A.2 - Elementos rectos monotubo vulcanizados en acero inoxidable. (Modelos RTR)	62
		2A.3 - Elementos tubulares planos TH (Modelos RKF)	63



	Page nº	Page nº
GROUP 3 - Electric process heating equipment suitable for hazardous area		
3.1 - Cabinet heaters (Models CREX)	44	
3.2 - Flexible heater blankets for drums. ATEX certified. (Models AFW-ATX)	66	
3.3 - Intermediate container heaters IBC. ATEX certified (Models IBCW-ATX)	66	
3.4 - ATEX certified heating blankets for gas cylinders (Models GCW)	67	
3.5 - Controladores de temperatura para equipos de calefacción ATEX (Models CLT-ATX)	67	
3.6 - Drum heater for classified zones (Models HIDH)	67	
3.7 - Immersion heaters with screw cap coupler (Models REX-TR)	68	
(Models RFA-C)	69	
3.8 - Flange heaters REX-F	70 - 71	
3.9 - Convectors (Models FAW)	72 - 110	
3.8 - Air heaters (Models FUH)	73 - 108	
GROUP 4 - Flexible heating elements		
4.1 - Straight annealed elements adaptable for evaporators (Models RRFI)	74	
4.2 - Elements for evaporators or tray defrosting (Models EFI)	75	
4.3 - Flexible annealed copper heating elements for drain pipe defrosting (Models RFIE)	75	
4.4 - FOR-FLEX in rolls	76	
4.5 - FOR-FLEX silicone heating elements (Models SFF / SSFF / PSFF / PSSFF)	76	
4.6 - FORMEC-FLEX silicone + fiber glass heating elements (Models PVSFF / PPVSFF)	77	
4.7 - Fiber glass heating elements (Models VFF)	77	
4.8 - Flexible heating lead for terrariums (Models CFR)	77	
4.9 - Parallel-type constant power-output per metre heating cable (Models CCP)	78	
4.10 - Torpedo-type two-pole silicone resistors (Models RBS)	78	
4.11 - Heating hoses (Models ELH)	79	
4.12 - Silicone heating wire covered with tinned copper mesh (Models SFFM)	80	
4.13 - Flexible annealed copper tubing heating element for pipes (Models FFC)	80	
4.14 - Heating elements for compressors (Models CFF)	80	
4.15 - Self adhesive etched foil elements (Models BSA)	81	
4.16 - Flexible heating blankets for curing composites (Models SRV)	82	
4.17 - Flexible high temperature heating blankets for curing composites (Models FGH / SXH)	82	
4.18 - Self regulating heating cable (Models ESR / TRC / CAB)	83	
4.19 - High temperature heating bands (Models ELW-GN / ELW-VA / ELW-H).....	84	
(Models ELW-HS / ELW-Q)	85	
4.20 - Mineral insulation heating lead (Models ELK-MI)	85	
4.21 - Accessories and complements for FOR-FLEX and self regulating cable	86	
GROUP 5 - Self regulating heating elements		
5.1 - PTC surface heaters (Models EA / EB / HP)	87	
(Models HP / HT)	88	
5.2 - PTC heating elements for Anti-Frost application (Models FE)	88	
5.3 - PTC heating elemetns to heat up moving air (Models HR)	89	
5.4 - Fan heaters with PTC technology (Models HKL)	89	
GROUP 6 - Infrared radiation equipment		
6.1 - Infrared emitters (Models 77F)	90	
(Models 77P)	91	
(Models 81P)	92	
6.2 - Universal ceramic infrared emitters (Models IRU)	93	
6.3 - Quartz industrial halogen-infrared emitters (Models LCP / LCU)	93	
6.4 - MW/SW infrared emitters (Models IRCM / IRCC)	94	
6.5 - Accessories for MW / SW infrared emitters (Models H7RS / PRA-IRC))	95	
6.6 - MW / SW infrared heating equipment (Models FIRM / FIRCI)	95	
6.7 - Ceramic infrared emitters (Models OSC / OSCxxxK / OSCP)	96	
(Models OSPP / OSPG / OSH / OSHC / OSHP)	97	
(Models BOS)	98	
6.8 - Heating elements for infrared reflectors on stock farms (Models IGRR)	98	
6.9 - Quartz infrared panels (Models PQR / PQP / PQC)	99	
GROUP 7 - Industrial heating apparatus		
7.1 - Infrared heat emitters for open spaces. (Models IC / ICSAFE)	100 / 102	
7.2 - Heating elements for warm air guns (Models RCAPAC)	103	
7.3 - Electric industrial night storage heaters (Models ACN)	103	
7.4 - Air heaters (Models ANB)	104	
(Models RMO / RMOB)	105	
(Models GAP)	106	
7.5 - Aluminium injected emitters (Models RAD)	106	
7.6 - Hot-air curtains (Models COR)	107	
7.7 - Convectors (Models RIS / CIE)	109	
7.8 - Panels with infrared emitters (Models IRC / IM)	111	
GROUP 8 - Cartridge type elements		
8.1 - TH high heating density electric heating cartridges. (Models in mm / Models in inches)	112 - 113	



	Page nº		Page nº
8.2 - CFOR high heating density electric heating cartridges. (Models in mm)	114	11.20 - Compact multi-use controller with logging functions. (Models MultiCon)	135
8.3 - Extra-long monotube heating elements (Models CM)	115	11.21 - Solid state relays (SSR) (Models SO8 / SO9)	136
GROUP 9 - Clamp type elements		(Models SO4 / SGTA)	137
9.1 - CFOR high performance shapeable elements (Models RCFR / RCFRC / RCFRR)	116	11.22 - Configurable digital thyristor units (Models CD3200 / CD3000M)	138 / 143
9.2 - TH high performance shapeable elements (Models ATB / ATBR / ATBRC / ATBRR)	117	11.23 - Safety valves for steam, gases and liquids (Models SV604 / SV607)	145
9.3 - Annealed straight square tubes (Models TC)	118	(Models SV615)	146
9.4 - Clamp heating elements	119	(Models SV6205 / SV6217)	147
9.5 - Flat heating elements	119	(Models SV6370 / SV6395)	148
9.6 - Connectors	119	11.24 - Magnetic level switches (Models IMN INOX)	149
9.7 - Hermetic clamps for nozzles (Models RCAH45 / RCAH30-I)	120	(Models IMN PVC)	150
9.8 - Monotube heating elements of 2 circuits with triangular profile (Models L-ETM)	121	11.25 - Level control: resistive probes (Models NS / NR / NRA)	151
9.9 - Triangular "Clamp" heating elements (Models L-ENC-FE)	121	11.26 - Level control: Level relays (Models PNSA)	151
GROUP 10 - Small electric home appliance elements		GROUP 12 - Electrical cable and insulating sheaths	
10.1 - Shielded kitchen plates	122	12.1 - Insulating sheaths for high and very high temperature (Models TU-FIVI / TU-FIVISI / TU-SILICIO)	152
10.2 - Heater bars with or without support (Models BF)	122	12.2 - Fiber glass covered electrical nickel cable	153
(Models BZ)	122	12.3 - Silicone covered electrical copper cable	153
10.3 - Markers, burners and lighters (Modelos PA)	122	GROUP 13 - Limescale control and cold production	
GROUP 11 - Control regulation		13.1 - Magnetic anti-calcium that reduces corrosion	153
11.1 - Capillary thermostats	8 - 124	13.2 - Peltier cells, TEC's (Models TCEC1)	154
11.2 - Rod thermostats (Models TER-xxx-NEF)	8 - 125	GROUP 14 - Electric heating panels for breeding and care of animals	
11.3 - Thermostats for monoblock (Models TER-CO / TER-AR / TER-BU)	14 - 125	14.1 - Electric heating panels for breeding and care of animals (Models PCG)	155
11.4 - Control and switch boards (Models ACO / ACT)	26 - 126	(Models PIG / BOS)	156
11.5 - Thermostats for acids and aggressive liquids (Models TERACTE / TERACTI / TERACTY)	32	GROUP 15 - De-misting elements for mirrors	
11.6 - Control elements for cabinet heaters (Models REX / ERF / ETF / FZK / FTO / FTS)	45	15.1 - De-misting elements for mirrors (Models STOP VAPOR)	157
11.7 - Anti-Legionella electronic thermostat (Models LEGIONELUS)	86 - 128	GROUP 16 - Heaters and accessories for aquariums, terrariums and gardens	
11.8 - Electronic thermostat. (Models CTX)	86 - 133	16.1 - Ultra-thin external heating pad for terrariums (Models TERRA)	157
11.9 - Fixed temperature thermostats (Models 206 / 2TT / PK1 / 1NT / 15AM / 9700 / 2MM / TH10)	123	TECHNICAL NOTES	158 / 162
11.10 - Thermal Fuses	124		
11.11 - Double action bimetallic thermostats (Models TER-Z01)	125		
11.12 - Regulators (Models MR-1 / MR-2)	126		
11.13 - Time switches (Models IHA / IHD)	127		
11.14 - Starting relay for motors (Models 2CR3 / 2CR4)	127		
11.15 - Differential thermostats (Models ALLEGRO 400 / FC200)	128		
(Models ALLEGRO 33)	128		
11.16 - Temperature sensors: thermocouples and RTD sensors	129 / 131		
11.17 - Configurable temperature controller with display (Models TTM)	132		
11.18 - Configurable multi-input controller 48x96 DIN (Models XE)	123		
11.19 - Graphic and data logger (Models SRD-99)	134		



GROUP 0 - Introduction

0.1 - Construction: tubular heating element parts

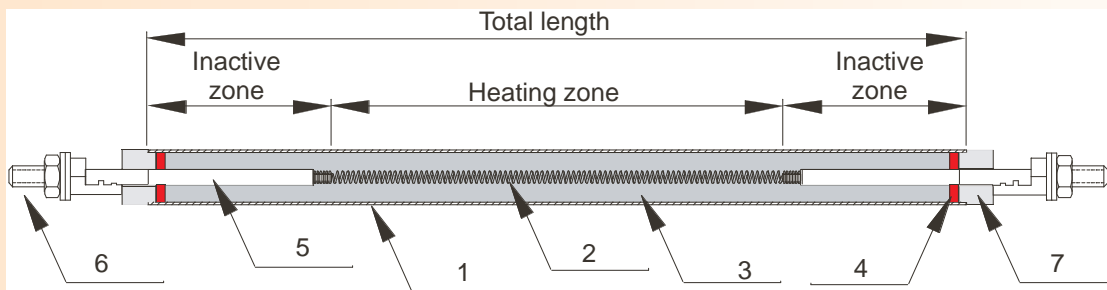

1.- Tubular sheath

It changes based on the material to heat and the working temperature. See attached table with some of the most standard materials sheaths, also with the different diameter options and tube lengths

2.- Resistive coil

Resistive wire of Nickel Chrome alloy or other metals. The alloy changes according to the type of application of the heating element. The resistive coil can be made with one, two or three wires.

This element is the heat source.

3.- Granular insulating

Magnesium oxide electrofused with the adequate characteristics to Electricfor's constructive thermic class. When the magnesium oxide is compacted by lamination or compression it acquires a good thermal conductivity as well as ensuring correct dielectric strength.

4.- Seal

It protects against humidity penetrating the heating element. Five types of seal according to Electricfor's constructive thermic class:

- Airtight seal.
- Extra airtight seal.
- Extra airtight high temperature seal.
- Porous seal.
- Porous high temperature seal

5.- Terminal

In prenickel steel, stainless steel AISI 303 or steel.

The length of internal terminal determines the cold zone of the heating element.

6.- Connection terminal

Different types of terminal to connect to electricity supply.

7.- Insulation terminal

Ceramic or thermoplastic wallhole to ensure the dielectric strength between tubular sheath and terminal.

GROUP 0 - Introduction

0.2 - EC Conformity statement

CE CONFORMITY STATEMENT

Electricfor, S.A. declares that all the products described in this catalogue fulfil the requirements of the Community's Directive on Low Voltage 73/23 EEC and the Directive on Electromagnetic Accountability 89/336 EEC. For this reason, the accepted EC standards are applied in the design and manufacture of our products, with emphasis on:

- UNE-EN 60.335 Safety of household and similar electrical appliances - General requirements
- UNE-EN 60.335-2-9 Safety of household and similar electrical appliances - Particular requirements for toasters, grills, boilers and similar appliances.
- UNE-EN 60.335-2-15 Safety of household and similar electrical appliances - Particular requirements for appliances for heating liquids.
- UNE-EN 60.335-2-30 Safety of household and similar electrical appliances - Particular requirements for room heaters.
- UNE-EN 60.335-2-73 Safety of household and similar electrical appliances - Particular requirements for fixed immersion heaters.
- UNE-EN 60.519 Safety in electrothermal installations
- EN 60.529 Degrees of protection provided by enclosures (IP Code)

For its products destined to form part of an end appliance, Electricfor ensures the points of the standards applicable. It is the responsibility of the appliance constructor to adopt the necessary measures to fulfil the standards in force.

(1) Referring mainly to tolerances in power and intensity, leakage currents, dielectric strength, screws and connections, escape lines, distances in the air and distances through the insulation.



The heating elements bearing the attached symbol are considered components of a final appliance which cannot in themselves guarantee protection against electric shock in accessible metallic parts. It is responsibility of the constructor of the end appliance to adopt the protection measures and/or earthing devices according to standards in force.

GROUP 0 - Introduction

0.3 - Quality assurance

Electricfor assures in its heating elements manufacturing process the maintenance of the standards of design applied. For our standardised products, the following systematic controls are carried out among others

Class I elements

- Power: +5%
-10%
- Dielectric strength: 1250 V - 1 min.
- Leakage current: 0,75 mA / kW (max. 5 mA)
- Dimensions: General according IT15

Class II elements

- Power: +5%
-10%
- Dielectric strength: 500 V - 1 min In event of a **basic insulation** in normal use with a **safety extra low voltage**
1000 V - 1 min for any **basic insulation**
2750 V - 1 min for a **supplementary insulation**
3750 V - 1 min for a **reinforced insulation**
- Leakage current: 0,25 mA
- Dimensions: General according IT15

In products of special manufacture, the control parameters are personalised from the design according to the needs of each case

In compliance with these chapters, the measures required by the norm are carried out under normal functioning temperature. Electricfor carries out measures at the highest temperature admitted by each product. One needs to take into consideration that if a sufficient extraction of heat of the resistance isn't guaranteed, it can exceed the maximum temperature and melt or deteriorate. To make sure that the element, once installed on the final heater, keeps on fulfilling the EC norm you will only need to measure the temperatures of the seal and sheath in all the situations likely to occur, whether during normal use, abnormal functioning or during overheating, and check that it remains within the limits of utilisation of the product detailed below. It is specially advised to study the functioning without a product to heat, for example without ventilation or without being immersed in water, depending on the products. It necessary take the adequate measures in order to avoid the resistance functioning in such conditions and inform the user of the precautions to take.



The object of the **Electricfor constructive thermic classes** is to define a standard construction of heating elements depending on the sheath material, its maximum permissible temperature and the type of seal. These three characteristics, and above all the sheath material, should always be chosen bearing in mind the medium in which the element is to work.

SHEATH MATERIALS

- **AISI 304L:** Austenitic stainless steel. It presents optimum ability for soldering and good resistance to corrosion at room temperature. If it is kept for some time within the critical temperature interval of 450 to 850°, an inter-crystalline precipitation of chrome carbide may occur with the consequential inter-granular corrosion.
- **AISI 321:** A specific amount of titanium is added to the components of the AISI304 with the effect of preventing formation of chrome carbide and, thus, preventing the phenomenon of inter-granular corrosion, making this material particularly suitable for use over prolonged periods of time at critical temperature interval. It has good resistance to formation of cinders up to 800°C
- **AISI 316L:** It contains an addition of 2-3% molybden that gives it greater resistance to corrosion by pitting and better performance than the previous steels as far as low tension corrosion is concerned. Carbon content lower than 0.03% that makes it difficult for chrome carbide to form, thus increasing its resistance to inter-granular corrosion.
- **INCOLOY® 800:** Refractory stainless steel with high nickel and chrome content. Good resistance to formation of cinders up to 1,100°C. It presents high resistance to tension and good resistance to corrosion at high temperatures.
- **INCOLOY® 825:** This is a nickel-iron-chrome alloy with additions of molybden and copper. It offers good resistance to both reducing and rusting acids, to corrosion due to tension, to pitting and to interstitial corrosion.
® Brand-name registered by "The International Nickel Co."
- **COPPER (SF-Cu DIN 1787):** Semi-noble metal and by nature highly resistant to corrosion by water.
- **TITANIUM:** Titanium is a metallic element that presents a compact hexagonal structure, it is hard, refractory and a good conductor of electricity and heat. It presents high resistance to corrosion. Resistance to corrosion that it presents is owing to the phenomenon of passivation that it undergoes (an oxide that coats it if formed)

TYPES OF SEAL

- **Airtight seal:** this seal does not allow moisture to enter the element, maintaining insulation values for more than five years. Sheath and seal temperature should not exceed 300°C and 150°C respectively. If the sheath temperature exceeds 300°C or the seal temperature exceeds 150°C, insulation values decrease rapidly and leaks appear within a short time.
- **Extra airtight seal:** this seal does not allow the entry of moisture into the element either, maintaining the insulation values for more than ten years. In this case, temperature of the sheath can reach up to 600°C. If the sheath temperature exceeds 600°C or the seal temperature exceeds 150°C/250°C (according to thermic class), insulation values decrease rapidly and leaks appear within a short time.
- **Transpirable seal:** When an element works at over 600°C, it consumes oxygen. If the seal does not permit entry of such, the life of the element is reduced by about 100 hours. Thus, a seal has been designed to allow air to enter in sufficient quantities so as to permit correct respiration of the element. However, for proper respiration to occur, you should check that the element is halted for intervals of over 5 minutes, at least 15% of the time, and that it does not work without stopping for over 8 consecutive hours. Stoppages can easily be those originated by mediums of control, such as thermostats, etc. in the usual way in the majority of applications.

Due to the special conditions of this seal, on allowing the entry of air, it also allows moisture to enter, thus insulation can decrease to values of about 1 MΩ and, at the time of connecting, after a prolonged halt, transitory leaks of current may occur. These leaks may reach up to 5 mA per kilowatt during this period, then drop to values of 0.2 mA per kilowatt until the temperature is established. In order to ensure that the leaks disappear before temperature stabilisation is reached, and thus comply with UNE-EN-60335 standards, it must be ensured that the seal temperature is at least 110°C.

LIMITS OF USE OF THE HEATING ELEMENTS

Electricfor's constructive thermic class	Tube's protection		Seal		Seal temperature (base)			
	Maximum temperature	Tube material	Type	Designation	Minimum temperature		Maximum temperature	
					Off	On	Under regular use	Under peak
T-175-E	175 °C	Cobre	E	AIRTIGHT	-40 °C	--	150 °C	170 °C
T-270-E	270 °C	AISI 304L or 321 covered by a tube of Teflón®	E	AIRTIGHT	-40 °C	--	150 °C	170 °C
T-300-E	300 °C	AISI 304L or 321	E	AIRTIGHT	-40 °C	--	150 °C	170 °C
T-301-E	300 °C	AISI 316L	E	AIRTIGHT	-40 °C	--	150 °C	170 °C
T-440-E	440 °C	Titanium	E	AIRTIGHT	-40 °C	--	150 °C	170 °C
T-450-E	500 °C	Steel	E	AIRTIGHT	-40 °C	--	150 °C	170 °C
T-600-S	600 °C	AISI 304L or 321	S	EXTRA AIRTIGHT	-40 °C	--	150 °C	170 °C
T-601-S	600 °C	AISI 316L	S	EXTRA AIRTIGHT	-40 °C	--	150 °C	170 °C
T-602-S	600 °C	Incoloy® 800 or 825	S	EXTRA AIRTIGHT	-40 °C	--	150 °C	170 °C
T-600-H	600 °C	AISI 304L or 321	H	EXTRA AIRTIGHT	-40 °C	--	250 °C	280 °C
T-601-H	600 °C	AISI 316L	H	EXTRA AIRTIGHT	-40 °C	--	250 °C	280 °C
T-602-H	600 °C	Incoloy® 800 or 825	H	EXTRA AIRTIGHT	-40 °C	--	250 °C	280 °C
T-700-T	700 °C	AISI 304L or 321	T	POROUS	-40 °C	(*) 110 °C	200 °C	250 °C
T-750-T	750 °C	AISI 304L or 321	T	POROUS	-40 °C	(*) 110 °C	200 °C	250 °C
T-850-T	850 °C	Incoloy® 800	T	POROUS	-40 °C	(*) 110 °C	200 °C	250 °C
T-750-C	750 °C	AISI 304L or 321	C	POROUS	-40 °C	(*) 110 °C	(**) 750 °C	(**) 750 °C
T-850-C	850 °C	Incoloy® 800	C	POROUS	-40 °C	(*) 110 °C	(**) 850 °C	(**) 850 °C

The temperature of the tube protection is measured by a thermopar of thin wire fin and little weight sealed to the heating zone of the resistance.

(*) In porous seals, leaks may reach 5 mA per kilowatt during heating, however they remain within the limits of the values imposed by the norm when the regular working temperature is reached and as long as the temperature of the seal reaches a minimum of 110 °C. For this reason we recommend that you do not opt for such a seal unless absolutely necessary due to the temperature that the seal or the tube will have to reach.

(**) The maximum temperature of the sealing coincides with the maximum temperature permitted in the tube sheath. Whatever, when installing, other temperature limitations should be kept in mind, such as the maximum temperature in the supply conductors, terminal pins, flanges, etc.

While designing the heater in which the resistors will be included, it has to be taken into account that the temperature reached by the resistors should not dangerously affect the other parts of the heater.

In order to ensure a reasonable life expectancy, you should check the capacity of the protecting material in resisting corrosion in the real conditions created by the machine in operation. We remind you that even stainless steel in drinking water may show signs of corrosion. For more information, see our technical sheet NTT-4101, or contact our Technical-Commercial department.



Your design team partner

The experience of 75 years of manufacturing heating elements has taught us that some systems don't work because the elements don't contribute enough heat, there is bad regulation or none at all, the materials used aren't the most appropriate ones, with the consequent risk of defects in the elements, etc. On the other hand, we find systems that are overly large and the consequences of such: more energy consumption than required, systems that are too inertial, etc. All of these factors lead to increased costs in your production system and even to halts in manufacturing.

At Electricfor S.A., we know that communication between customer and manufacturer is fundamental for satisfying needs as far as functioning, quality and price are concerned. Therefore, our team of Sales Technicians, together with the client, takes stock of the situation and decides how to approach it and solve the "problem". At the same time, the sales technicians work side by side with the Technical Office and the R+D department, improving the final product to the maximum.

We know that the Universal Solution doesn't always exist, but for Electricfor, customer service is first, that's why our Technical Office has great flexibility with the mass produced products, and if we cannot adapt ourselves to what has been requested, our R+D department will create and design the product that best meets your requirements.

Continuous market research and development of new products and processes (know-how) ensures that our team will always be up-to-date in new technologies in order to be able to transmit them and incorporate them into the products we offer you.

PRODUCTION SCHEDULE FOR SHIELDED TUBULAR ELEMENTS

	Tube material	Standardised options of tube diameter. Round or square tube													
		Ø6,4	Ø8	Ø8,5	Ø9,60 (*)	Ø10 (*)	Ø10,92	Ø12	Ø12,5	Ø16	Class II Ø16	▧ 6,1	▧ 7,6	▧ 9,65	
Maximum tube length in mm	AISI 321	3800	6800	6800	6900	6900	6600	---	6900	6200	1450	3600	6100	3600	
	AISI 304L														
	AISI 304	3800	6800	---	---	6900	---	---	---	6200	---	---	---	---	
	AISI 316L	3800	6800	6800	6900	6900	---	---	6900	6200	1450	3600	6000	---	
	254 SMO Austenitic stainless steel	---	---	---	---	---	---	---	6900	---	---	---	---	---	
	Incoloy® 800	3800	7000	---	6900	6900	6600	---	6900	---	---	---	3600	6000	---
	Incoloy® 825	---	6800	---	6900	6900	---	---	---	---	---	---	---	---	---
	AISI 309S	3500	6800	---	6900	6900	---	---	---	6200	---	---	3600	---	---
	Steel	3500	7000	---	7100	7100	---	---	---	6400	---	---	3700	---	---
	Copper	3900	7100	7100	5900	5900	---	---	---	6400	---	---	3600	6000	---
	Titanium	---	6900	---	---	6850	---	---	6900	6900	---	---	---	---	---
	Aluminium	---	500	---	---	500	---	---	---	---	---	---	---	---	---
	Teflon®	---	---	---	---	---	---	6900	---	---	---	---	---	---	---

(*) Also in monotube up to max. length 1300 mm. See more information on page nº 115



Heating elements UL Listed for U.S. and Canada

Electricfor can supply heating elements on demand with UL certification (Underwriters Laboratories) for U.S. and Canada and delivered with trademark 

The heating elements in this catalog incorporates the symbol  can be manufactured with UL certification, file E336613. Please consult us to discuss your needs within the scope of our certification in heating elements.

STANDARDISED PRODUCTS

Electricfor is aware of market demands. In our constant search for total customer satisfaction, is very important to minimize the delivery time of our products. That's why we have decided to daily expand our range of articles, standardise them and stock them, so that in a high percentage of cases we can offer immediate and real solutions from our commercial engineering department.

SPECIAL MANUFACTURES

One of our specialities is to manufacture any kind of heating elements. We can do it from a plan or a sample, or also design a new one answering concrete needs. In these cases our delivery dates are:

NORMAL CIRCUIT - 21 working days.

URGENT CIRCUIT - 10 working days.

HOT CIRCUIT - 4 working days. (request for specification sheet)

DESIGN CREATION - 2 to 45 working days depending on complexity.

TRADEMARKS: ELECTRICFOR / CFOR





Usual applications

- Steam boilers
- Water baths
- Warming of diesel fuel
- Water heaters
- Oil chambers
- Distillation
- Cleaning
- Dyeing
- Liquid convection heating radiators
- Towel dryers
- Degreasing
- Endothermal or exothermal reactions requiring it
- Heating by circulation of liquids
- Fish farms
- Boiling vats
- Cooking vats
- Chemical industries
- Electromedicine...

General characteristics

- Tubular element of nickel-plated copper or stainless steel AISI 321 of Ø8 mm
- BSP threaded plug of stamped brass
- Polyester with fiber glass or bichromed zinc-plated steel protection hood, with degree protection against moisture IP-40.
- Optionally, all the models with BSP thread of 1 1/2", 2" and 2 1/2" can be supplied with aluminum connection box IP-66.
- Welded with silver alloy for stainless steel tube and with copper alloy for copper tube.
- Standard voltage ~230 V
- By request, special heating elements can be made according to your specifications:
 - Material tube: AISI 316L, Incoloy®-800, Incoloy®-825 and Titanium
 - Stainless steel or titanium BSP threaded plugs.

U-SHAPED HEATING ELEMENT WITH BRASS COUPLING PLUG

Code	L in mm	BSP Threaded plug	Watts	W/cm ²	Tube material	Peso en Kg	Electricfor's construct. thermic class	Box connection range	
								IP-40 (1)	IP-66 (2)
NA001	170	3/4"	500	8,3	SS	0,21	T-300-E	C-FE-3/4"	---
NA001C	170	3/4"	500	8,3	Cu	0,21	T-175-E	C-FE-3/4"	---
NA002	180	1 1/4"	500	8,3	SS	0,28	T-300-E	C-MENZ	Range P3
NA002C	180	1 1/4"	500	8,3	Cu	0,28	T-175-E	C-MENZ	Range P3
NA101	180	1"	500	8,3	SS	0,21	T-300-E	C-MENZ	---
NA101C	180	1"	500	8,3	Cu	0,21	T-175-E	C-MENZ	---
NA003	250	3/4"	750	7,5	SS	0,24	T-300-E	C-FE-3/4"	---
NA003C	250	3/4"	750	7,5	Cu	0,24	T-175-E	C-FE-3/4"	---
NA004	260	1 1/4"	750	7,5	SS	0,32	T-300-E	C-MENZ	Range P3
NA004C	260	1 1/4"	750	7,5	Cu	0,32	T-175-E	C-MENZ	Range P3
NA103	260	1"	750	7,5	SS	0,25	T-300-E	C-MENZ	---
NA103C	260	1"	750	7,5	Cu	0,25	T-175-E	C-MENZ	---
NA104C	260	1 1/2"	750	7,5	Cu	0,30	T-175-E	C-MENZ	---
NA005	340	3/4"	1000	7	SS	0,28	T-300-E	C-FE-3/4"	---
NA005C	340	3/4"	1000	7	Cu	0,28	T-175-E	C-FE-3/4"	---
NA006	350	1 1/4"	1000	7	SS	0,35	T-300-E	C-MENZ	Range P3
NA006C	350	1 1/4"	1000	7	Cu	0,35	T-175-E	C-MENZ	Range P3
NA105	350	1"	1000	7	SS	0,29	T-300-E	C-MENZ	---
NA105C	350	1"	1000	7	Cu	0,29	T-175-E	C-MENZ	---
NA008	520	1 1/4"	1500	6,6	SS	0,44	T-300-E	C-MENZ	Range P3
NA008C	520	1 1/4"	1500	6,6	Cu	0,44	T-175-E	C-MENZ	Range P3
NA108	520	1"	1500	6,6	SS	0,36	T-300-E	C-MENZ	---
NA108C	520	1"	1500	6,6	Cu	0,36	T-175-E	C-MENZ	---
NA010	680	1 1/4"	2000	6,5	SS	0,50	T-300-E	C-MENZ	Range P3
NA010C	680	1 1/4"	2000	6,5	Cu	0,50	T-175-E	C-MENZ	Range P3

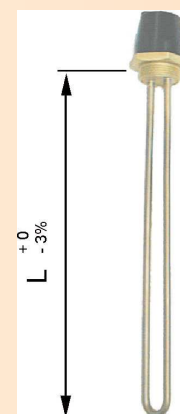

DOUBLE LOOP U-SHAPED HEATING ELEMENT WITH BRASS COUPLING PLUG

Code	L in mm	BSP Threaded plug	Watts	W/cm ²	Tube material	Weight in Kg	Electricfor's construct. thermic class	Box connection range	
								IP-40 (1)	IP-66 (2)
OV001	140	1 1/4"	600	7,1	SS	0,29	T-300-E	C-MENZ	Range P3
OV003	170	1 1/4"	800	7	SS	0,33	T-300-E	C-MENZ	Range P3
OV003C	170	1 1/4"	800	7	Cu	0,33	T-175-E	C-MENZ	Range P3
OV105	235	1 1/4"	400	2,2	SS	0,37	T-300-E	C-MENZ	Range P3
OV005	235	1 1/4"	1200	6,7	SS	0,42	T-300-E	C-MENZ	Range P3
OV005C	235	1 1/4"	1200	6,7	Cu	0,42	T-175-E	C-MENZ	Range P3
OV107	345	1 1/4"	900	3,1	SS	0,51	T-300-E	C-MENZ	Range P3
OV007	345	1 1/4"	1800	6,3	SS	0,51	T-300-E	C-MENZ	Range P3
OV007C	345	1 1/4"	1800	6,3	Cu	0,51	T-175-E	C-MENZ	Range P3
OV009	445	1 1/4"	2400	6,2	SS	0,56	T-300-E	C-MENZ	Range P3
OV009C	445	1 1/4"	2400	6,2	Cu	0,56	T-175-E	C-MENZ	Range P3
OV111	505	1 1/4"	1000	2,2	SS	0,61	T-300-E	C-MENZ	Range P3
OV211	505	1 1/4"	1500	3,4	SS	0,61	T-300-E	C-MENZ	Range P3
OV011	505	1 1/4"	3000	6,7	SS	0,61	T-300-E	C-MENZ	Range P3
OV011C	505	1 1/4"	3000	6,7	Cu	0,61	T-175-E	C-MENZ	Range P3

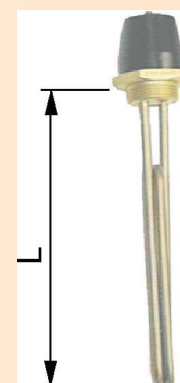

TRIPLE LOOP U-SHAPED HEATING ELEMENT WITH BRASS COUPLING PLUG

Code	L in mm	BSP Threaded plug	Watts	W/cm ²	Tube material	Weight in Kg	Electricfor's constructive thermic class	Box connection range	
								IP-40 (1)	IP-66 (2)
T001	150	1 1/4"	750	5	Inox	0,36	T-300-E	C-MENZ	Range P3
T003	200	1 1/4"	1000	4,4	Inox	0,24	T-300-E	C-MENZ	Range P3
T005	250	1 1/4"	1500	5,7	Inox	0,49	T-300-E	C-MENZ	Range P3
T007	350	1 1/4"	2000	4,5	Inox	0,62	T-300-E	C-MENZ	Range P3
T108	250	2"	2000	4,9	Inox	0,86	T-300-E	C-FE-2"	---
T009	450	1 1/4"	2500	4,2	Inox	0,74	T-300-E	C-MENZ	Range P3
T011	550	1 1/4"	3000	4	Inox	0,88	T-300-E	C-MENZ	Range P3

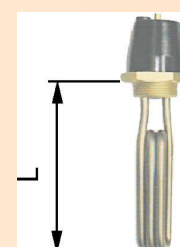

Note 1: Standard junction box. It is always given with the heater.

Note 2: Aluminum junction box. Optional. Delivered on request (see page # 7)

Note 3: In the elements with 3/4" BSP coupling plug, the protection hood is optional and is not included in price. Code 108006001

Note 4: If you require weldable flanges, nuts and threaded adapters for all these elements, see page # 9

General characteristics

- Tubular element of nickel-plated copper or stainless steel AISI 321 of Ø8 mm
- BSP threaded plug of stamped brass
- Polyester with fiber glass or bichromed zinc-plated steel protection hood, with degree protection against moisture IP-40.
- Optionally, all the models with BSP thread of 1 1/2", 2" and 2 1/2" can be supplied with aluminum connection box IP-66.
- Welded with silver alloy for stainless steel tube and with copper alloy for copper tube.
- Standard voltage 3~230 V Δ, 3~400 V Δ
- By request, special heating elements can be made according to your specifications:
 - Material tube: AISI 316L, Incoloy®-800, Incoloy®-825 and Titanium
 - Stainless steel or titanium BSP threaded plugs.



TRIPLE U-SHAPED HEATING ELEMENT WITH BRASS COUPLING PLUG

Code	L in mm	BSP Threaded plug	Watts	W/cm²	Tube material	Weight in Kg	Electricfor's construct. thermic class	Connection box range	
								IP40 (1)	IP66 (2)
DP001	180	2"	1500	8,3	Inox	0,76	T-300-E	C-PA-2"	Range M1
DP001C	180	2"	1500	8,3	Cu	0,76	T-175-E	C-PA-2"	Range M1
DP003	260	2"	2250	7,5	Inox	0,87	T-300-E	C-PA-2"	Range M1
DP003C	260	2"	2250	7,5	Cu	0,87	T-175-E	C-PA-2"	Range M1
DP005	350	2"	3000	7	Inox	1,0	T-300-E	C-PA-2"	Range M1
DP005C	350	2"	3000	7	Cu	1,0	T-175-E	C-PA-2"	Range M1
DP007	520	2"	4500	6,6	Inox	1,2	T-300-E	C-PA-2"	Range M1
DP007C	520	2"	4500	6,6	Cu	1,2	T-175-E	C-PA-2"	Range M1
DP009	680	2"	6000	6,4	Inox	1,4	T-300-E	C-PA-2"	Range M1
DP009C	680	2"	6000	6,4	Cu	1,4	T-175-E	C-PA-2"	Range M1
DP010	680	2 1/2"	6000	6,4	Inox	1,6	T-300-E	C-FE-2 1/2"	Range G1
DP025	180	1 1/2"	1500	8,3	Inox	0,53	T-300-E	C-MENZ	Range P1
DP025C	180	1 1/2"	1500	8,3	Cu	0,53	T-175-E	C-MENZ	Range P1
DP030C	180	1 1/2"	2000	9,5	Cu	0,53	T-175-E	C-MENZ	Range P1
DP026C	260	1 1/2"	2250	7,5	Cu	0,63	T-175-E	C-MENZ	Range P1
DP027C	350	1 1/2"	3000	7	Cu	0,79	T-175-E	C-MENZ	Range P1
DP031C	290	1 1/2"	3000	8,4	Cu	0,71	T-175-E	C-MENZ	Range P1
DP028C	520	1 1/2"	4500	6,6	Cu	1,0	T-175-E	C-MENZ	Range P1
DP029C	680	1 1/2"	6000	6,4	Cu	1,2	T-175-E	C-MENZ	Range P1
DP032C	315	1 1/2"	6000	14,5	Cu	0,74	T-175-E	C-MENZ	Range P1
DP021	415	1 1/2"	1200	2,2	Inox	0,84	T-300-E	C-MENZ	Range P1
DP022	635	1 1/2"	2700	3,1	Inox	1,1	T-300-E	C-MENZ	Range P1
DP023	956	1 1/2"	3000	2,2	Inox	1,5	T-300-E	C-MENZ	Range P1
DP024	956	1 1/2"	4500	3,4	Inox	1,5	T-300-E	C-MENZ	Range P1

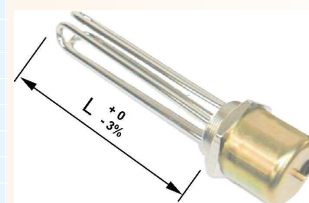

DOUBLE LOOP TRIPLE U-SHAPED HEATING ELEMENT WITH BRASS COUPLING PLUG

Code	L in mm	BSP Threaded plug	Watts	W/cm²	Tube material	Weight in Kg	Electricfor's construct. thermic class	Connection box range	
								IP40 (1)	IP66 (2)
ED001	140	2"	1800	7,1	SS	0,84	T-300-E	C-FE-2"	Range M1
ED002C	140	2 1/2"	1800	7,1	Cu	1,2	T-175-E	C-FE-2 1/2"	Range G1
ED003	170	2"	2400	7	SS	0,92	T-300-E	C-FE-2"	Range M1
ED003C	170	2"	2400	7	Cu	0,92	T-175-E	C-FE-2"	Range M1
ED105	235	2"	1200	2,2	SS	1,1	T-300-E	C-FE-2"	Range M1
ED005	235	2"	3600	6,7	SS	1,1	T-300-E	C-FE-2"	Range M1
ED005C	235	2"	3600	6,7	Cu	1,1	T-175-E	C-FE-2"	Range M1
ED107	345	2"	2700	3,1	SS	1,4	T-300-E	C-FE-2"	Range M1
ED007	345	2"	5400	6,3	SS	1,4	T-300-E	C-FE-2"	Range M1
ED007C	345	2"	5400	6,3	Cu	1,4	T-175-E	C-FE-2"	Range M1
ED008	345	2 1/2"	5400	6,3	SS	1,6	T-300-E	C-FE-2 1/2"	Range G1
ED008C	345	2 1/2"	5400	6,3	Cu	1,6	T-175-E	C-FE-2 1/2"	Range G1
ED009	445	2"	7200	6,2	SS	1,6	T-300-E	C-FE-2"	Range M1
ED009C	445	2"	7200	6,2	Cu	1,6	T-175-E	C-FE-2"	Range M1
ED109	445	2 1/2"	7200	6,2	SS	1,8	T-300-E	C-FE-2 1/2"	Range G1
ED110	505	2"	3000	2,2	SS	1,8	T-300-E	C-FE-2"	Range M1
ED111	505	2 1/2"	3000	2,2	SS	1,9	T-300-E	C-FE-2 1/2"	Range G1
ED210	505	2"	4500	3,4	SS	1,8	T-300-E	C-FE-2"	Range M1
ED211	505	2 1/2"	4500	3,4	SS	1,9	T-300-E	C-FE-2 1/2"	Range G1
ED010	505	2"	9000	6,7	SS	1,8	T-300-E	C-FE-2"	Range M1
ED010C	505	2"	9000	6,7	Cu	1,8	T-175-E	C-FE-2"	Range M1
ED011	505	2 1/2"	9000	6,7	SS	1,9	T-300-E	C-FE-2 1/2"	Range G1
ED011C	505	2 1/2"	9000	6,7	Cu	1,9	T-175-E	C-FE-2 1/2"	Range G1
ED012C	680	2"	12000	6,6	Cu	2,3	T-175-E	C-FE-2"	Range M2
ED013C	680	2 1/2"	12000	6,6	Cu	2,5	T-175-E	C-FE-2 1/2"	Range G1
ED014C	835	2"	15000	6,6	Cu	2,9	T-175-E	C-FE-2"	Range M2
ED015C	835	2 1/2"	15000	6,6	Cu	3,1	T-175-E	C-FE-2 1/2"	Range G1
ED016C	990	2"	18000	6,5	Cu	3,4	T-175-E	C-FE-2"	Range M2
ED017C	990	2 1/2"	18000	6,5	Cu	3,6	T-175-E	C-FE-2 1/2"	Range G2

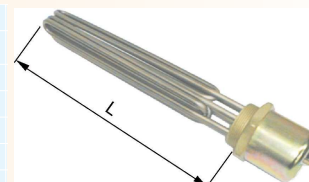

Note 1: Standard connection box. It is always given with the element.

Note 2: Aluminum connection box. Optional. Delivered on request (see page # 7)

Note: If you require weldable flanges, nuts and threaded adapters for all these elements, see the catalogue page # 9



GROUP 1 - Immersion heaters, drums heaters and accessories

1.1 - With coupling plug

ET

Models as per catalogue: 733

General characteristics

- Tubular element of nickel-plated copper of Ø8 mm
- BSP threaded plug of stamped brass
- Polyester with fiber glass or bichromed zinc-plated steel protection hood, with degree protection against moisture IP-40.
- Optionally, all the models with BSP thread of 1 1/2", 2" and 2 1/2" can be supplied with aluminum connection box IP-66.
- Welded with silver alloy for stainless steel tube and with copper alloy for copper tube.
- Standard voltage 3~230 V Δ, 3~400 V Λ
- By request, special heating elements can be made according to your specifications:
 - Material tube: AISI 316L, Incoloy®-800, Incoloy®-825 and Titanium
 - Stainless steel or titanium BSP threaded plugs.

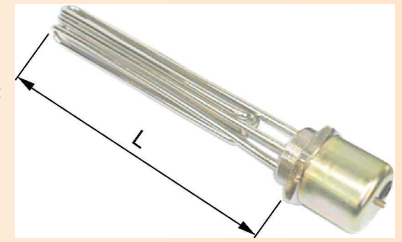

TRIPLE LOOP TRIPLE U-SHAPED HEATING ELEMENT WITH BRASS COUPLING PLUG

Code	L in mm	BSP Threaded plug	Watts	W/cm²	Tube material	Weight in Kg	Electricfor's construct. thermic class	Connection box range	
								IP40 (1)	IP66 (2)
ET401C	355	2 1/2"	9000	6,7	Cu	2,1	T-175-E	C-FE-2"1/2	Range G1
ET402C	465	2 1/2"	12000	6,6	Cu	2,6	T-175-E	C-FE-2"1/2	Range G1
ET403C	570	2 1/2"	15000	6,6	Cu	3,0	T-175-E	C-FE-2"1/2	Range G2
ET404C	680	2 1/2"	18000	6,5	Cu	3,6	T-175-E	C-FE-2"1/2	Range G2

Note 1: Standard connection box. It is always given with the element.

Note 2: Aluminum connection box. Optional. Delivered on request (see page # 7)

Note: If you require weldable flanges, nuts and threaded adapters for all these elements, see the catalogue page # 9

GROUP 1 - Immersion heaters, drums heaters and accessories

1.2 - Titanium heaters with coupling plug

TIM



TITANIUM HEATERS WITH COUPLING PLUG, TIM RANGE

The titanium tube and screw-cap TIM electrical resistors range is used to heat all kinds of water, of whatever source and treatment (e.g. seawater, chlorine treatment, bromine, ozone, electrophysical, electrochemical, and chlorine-free products).

General Characteristics

- Ø8 mm tubular elements in titanium
- Electrocasted and roll-compressed magnesium-oxide insulated resistor.
- 1" 1/2-thread Gas titanium screw heads
- Aluminium terminal box with damp protection grade IP-66
- **Attention:** aluminium connection box and thermostat of bulb not included in price. See page # 7
- With titanium casing of Ø9.5 x 0.5 mm for temperature sensors.
- Welds with titanium filler metal
- Standard voltage 3~230 V Δ, 3~400 V
- On request, resistors can be fabricated to order according to your specifications:

Standardised models

Code	L in mm	BSP Threaded plug	Watts	W/cm²	Tube material	Weight in Kg	Electricfor's constructive thermic class	Connection box range		Thermostat range
								WITHOUT thermostat	WITH thermostat	
TIM005	255	1" 1/2	3000	9,7	Titanium Ø8	0,6	T-440-E	Range D	Range P2	EG
TIM010	255	1" 1/2	4500	14,5	Titanium Ø8	0,6	T-440-E	Range D	Range P2	EG
TIM015	255	1" 1/2	6000	19,4	Titanium Ø8	0,6	T-440-E	Range D	Range P2	EG

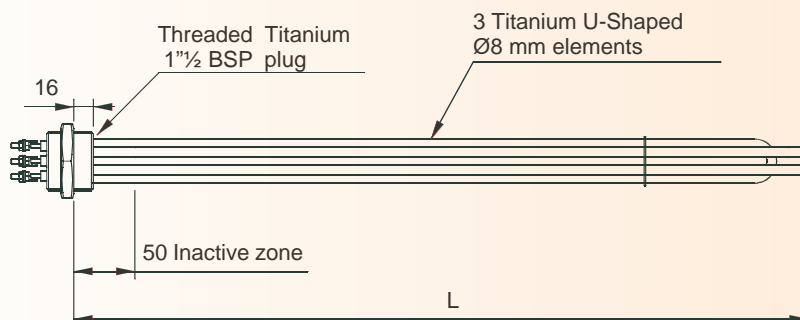



General characteristics

- Tubular element of Incoloy®-825 Ø8 mm
- BSP threaded plug of stamped brass.
- Polyester with fiber glass for models with coupling plug 1", 1"1/4, 1"1/2 and 2" BSP, with degree protection against moisture IP-40.
- Optionally, all the models with BSP thread of 1"1/4, 1"1/2 and 2" can be supplied with aluminum connection box IP-66.
- Welded with silver alloy for stainless steel
- By request, special heating elements can be made according to your specifications:
 - Material tube: AISI 316L, Incoloy®-800, Incoloy®-825 and Titanium
 - Stainless steel or titanium BSP threaded plugs.

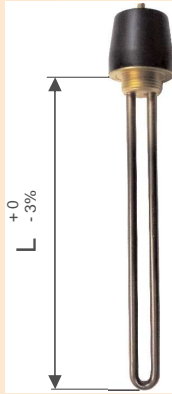

U-SHAPED HEATING ELEMENT WITH BRASS COUPLING PLUG

Code	L in mm	BSP Threaded plug	Watts	W/cm ²	Weight in Kg	Electric for's construct thermic class	Connection box IP40
NY001	180	1"	500	8,3	0,22	T-302-E	C-MENZ
NY003	260	1"	750	7,5	0,25	T-302-E	C-MENZ
NY007	350	1"	1000	6,9	0,29	T-302-E	C-MENZ
NY009	420	1"	1200	6,6	0,32	T-302-E	C-MENZ
NY011	520	1"	1500	6,5	0,36	T-302-E	C-MENZ
NY015	640	1"	1800	6,2	0,41	T-302-E	C-MENZ
NY017	680	1"	2000	6,4	0,43	T-302-E	C-MENZ
NY019	840	1"	2400	6,1	0,50	T-302-E	C-MENZ
NY021	960	1"	3000	6,6	0,55	T-302-E	C-MENZ
NY023	1320	1"	4000	6,3	0,70	T-302-E	C-MENZ

DOUBLE LOOP U-SHAPED HEATING ELEMENT WITH BRASS COUPLING PLUG



Code	L in mm	BSP Threaded plug	Watts	W/cm ²	Weight in Kg	Electric for's construct thermic class	Connection box range	
							IP40 (1)	IP66 (2)
OY003	205	1"1/4	1000	6,9	0,32	T-302-E	C-MENZ	Range P3
OY005	240	1"1/4	1200	6,6	0,35	T-302-E	C-MENZ	Range P3
OY007	290	1"1/4	1500	6,5	0,39	T-302-E	C-MENZ	Range P3
OY011	350	1"1/4	1800	6,2	0,44	T-302-E	C-MENZ	Range P3
OY013	370	1"1/4	2000	6,4	0,46	T-302-E	C-MENZ	Range P3
OY015	450	1"1/4	2400	6,1	0,53	T-302-E	C-MENZ	Range P3
OY017	510	1"1/4	3000	6,6	0,58	T-302-E	C-MENZ	Range P3
OY019	690	1"1/4	4000	6,3	0,73	T-302-E	C-MENZ	Range P3
OY021	860	1"1/4	5000	6,2	0,87	T-302-E	C-MENZ	Range P3
OY023	860	1"1/4	6000	7,3	0,99	T-302-E	C-MENZ	Range P3

TRIPLE U-SHAPED HEATING ELEMENT WITH BRASS COUPLING PLUG

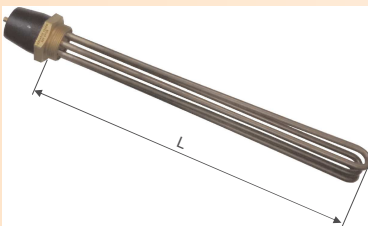

Code	L in mm	BSP Threaded plug	Watts	W/cm ²	Weight in Kg	Electric for's construct thermic class	Connection box range	
							IP40 (1)	IP66 (2)
DY001	180	1"1/2	1500	8,3	0,54	T-302-E	C-MENZ	Range P1
DY003	260	1"1/2	2250	7,5	0,64	T-302-E	C-MENZ	Range P1
DY007	350	1"1/2	3000	6,9	0,75	T-302-E	C-MENZ	Range P1
DY009	420	1"1/2	3600	6,6	0,84	T-302-E	C-MENZ	Range P1
DY011	520	1"1/2	4500	6,5	0,97	T-302-E	C-MENZ	Range P1
DY015	640	1"1/2	5400	6,2	1,12	T-302-E	C-MENZ	Range P1
DY017	680	1"1/2	6000	6,4	1,17	T-302-E	C-MENZ	Range P1
DY019	840	1"1/2	7200	6,1	1,37	T-302-E	C-MENZ	Range P1
DY021	960	1"1/2	9000	6,6	1,52	T-302-E	C-MENZ	Range P1
DY023	1320	1"1/2	12000	6,3	1,98	T-302-E	C-MENZ	Range P1

DOUBLE LOOP TRIPLE U-SHAPED HEATING ELEMENT WITH BRASS COUPLING PLUG



Code	L in mm	BSP Threaded plug	Watts	W/cm ²	Weight in Kg	Electric for's construct thermic class	Connection box range	
							IP40 (1)	IP66 (2)
EY003	205	2"	3000	6,9	0,98	T-302-E	C-PA-2"	Range M1
EY005	240	2"	3600	6,6	1,07	T-302-E	C-PA-2"	Range M1
EY007	290	2"	4500	6,5	1,20	T-302-E	C-PA-2"	Range M1
EY011	350	2"	5400	6,2	1,35	T-302-E	C-PA-2"	Range M1
EY013	370	2"	6000	6,4	1,40	T-302-E	C-PA-2"	Range M1
EY015	450	2"	7200	6,1	1,60	T-302-E	C-PA-2"	Range M1
EY017	510	2"	9000	6,6	1,75	T-302-E	C-PA-2"	Range M1
EY019	690	2"	12000	6,3	2,21	T-302-E	C-PA-2"	Range M1
EY021	860	2"	15000	6,2	2,63	T-302-E	C-PA-2"	Range M1
EY023	860	2"	18000	7,3	2,99	T-302-E	C-PA-2"	Range M1



General characteristics

- Tubular element of AISI 321 Ø8mm.
- Sheath 2" in stainless steel AISI 304 with 1.5mm thickness
- BSP threaded plug of stamped brass.
- Aluminium terminal box with damp protection grade IP-66 according to EN-60529.
- Exchangeable heating element without emptying the tank
- Heating elements with UL certification for USA and Canada with trade mark 

Note: If you require weldable flanges, nuts and threaded adapters for all these elements, see page # 9

Code	L in mm	Volts	Watts	W/cm ²	Weight in Kg	Electricfor's constructive thermic class
TRV008	300	230/400 V	800	1,0	1,1	T-600-E
TRV010	410	230/400 V	1000	1,5	1,5	T-600-E
TRV015	630	230/400 V	1500	1,5	1,7	T-600-E
TRV020	870	230/400 V	2000	1,5	2,3	T-600-E
TRV030	1290	230/400 V	3000	1,5	3,2	T-600-E

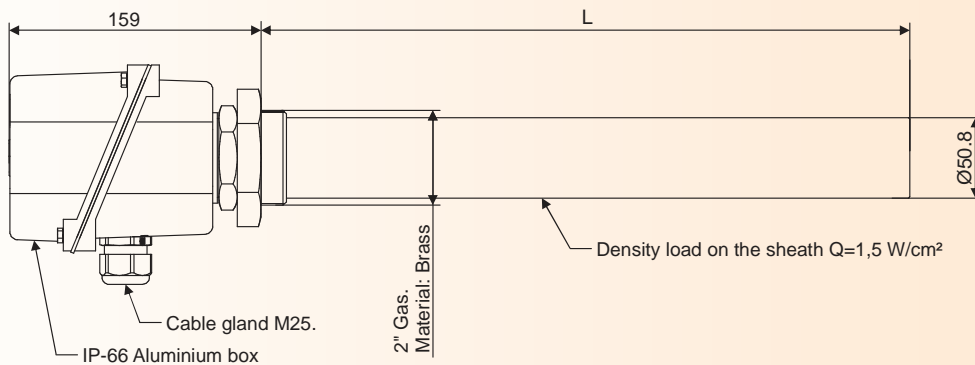

Heating element spare part. General characteristics

- Tubular element of AISI 321 Ø8mm.
- 1"1/2 BSP threaded plug of stamped brass
- Aluminium terminal box with damp protection grade IP-66 according to EN-60529.
- Heating elements with UL certification for USA and Canada with trade mark 

Code	L in mm	Volts	Watts	W/cm ²	Weight in Kg	Electricfor's constructive thermic class
RC-TRV008	290	230/400 V	800	2,5	1,1	T-600-E
RC-TRV010	400	230/400 V	1000	1,9	1,5	T-600-E
RC-TRV015	615	230/400 V	1500	1,8	1,7	T-600-E
RC-TRV020	870	230/400 V	2000	1,7	2,3	T-600-E
RC-TRV030	1265	230/400 V	3000	1,7	3,2	T-600-E

Sheath spare part. General characteristics

- 2 "BSP threaded plug of stamped brass.
- Sheath in stainless steel AISI 304

Code	L in mm	Weight in Kg
VA-TRV008	300	1,1
VA-TRV010	410	1,5
VA-TRV015	630	1,7
VA-TRV020	870	2,3
VA-TRV030	1290	3,2

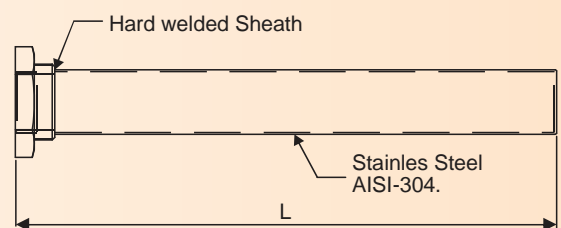
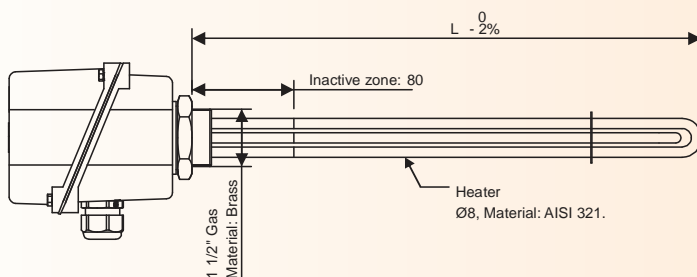



General characteristics

- Tubular element of nickel-plated copper, stainless steel AISI 321, stainless steel AISI 316l or steel
- Threaded plug of stamped brass or stainless steel AISI 304
- All the models are provided with sheath for thermostat of the same material as the tube, with the exception of models CR77CIA.
- Adjustable aluminium connection box, with degree protection against moisture IP-66 according to IEC-60529. Supplied with plastic pouch containing all connection, interlock and sealing accessories

(*) **Note:** If you require heating elements with threaded Gas plug, change the corresponding code
 45 for 112
 77 for 212

Example: Threaded brass 1" 1/2 Gas plug with 3 nickered copper U-Shaped elements of Ø 8mm, 2000 W
 Code: CR112CN0020

Attention: aluminium connection box and thermostat of bulb not included in price. See page # 7

Note: If you require weldable flanges, nuts and threaded adapters for all these elements, see page # 9

THREADED BRASS M45x2 or 1"1/2 BSP PLUG WITH 1 or 3 U-SHAPED Ø8 ELEMENTS, WITH SHEATH FOR THERMOSTAT

Tube material	Code (*)	L in mm	Nº elements	Watts	W/cm²	Weight in Kg	Electricfor's constructive thermic class	Connection box range		Thermostat range	
								WITHOUT thermostat	WITH thermostat		
Nickel-plated copper	CR112CN0020	205	3	2000	10,3	0,60	T-175-E	Range D	Range P2	EG	
	CR112CN0030	285	3	3000	9,6	0,68	T-175-E	Range D	Range P2	EG	
	CR112CN0040	360	3	4000	9,5	0,80	T-175-E	Range D	Range P2	EG	
	CR112CN0060	520	3	6000	9,1	1,0	T-175-E	Range D	Range P2	EG	
	Stainless steel 316-L	CR112CI0010	160	3	1000	8,3	0,24	T-301-E	Range D	Range P2	EG
		CR112CI0020	270	3	2000	7	0,48	T-301-E	Range D	Range P2	EG
CR112CI0030		380	3	3000	6,7	0,60	T-301-E	Range D	Range P2	EG	
CR112CI0050		600	3	5000	6,5	0,89	T-301-E	Range D	Range P2	EG	
	CR112CI0065	770	3	6500	6,4	1,1	T-301-E	Range D	Range P2	EG	

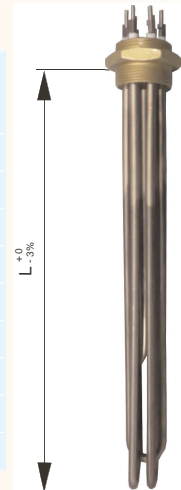

THREADED BRASS M77x2 or 2"1/2 BSP PLUG WITH 3 NICKEL-PLATED COPPER U-SHAPED Ø16 ELEMENTS, WITH SHEATH FOR THERMOSTAT

Code (*)	L in mm	Watts	W/cm²	Weight in Kg	Electricfor's constructive thermic class	Connection box range		Thermostat range
						WITHOUT thermostat	WITH thermostat	
CR212CN0040	230	4000	8,7	1,8	T-175-E	Range G1	Range G1	EG
CR212CN0060	310	6000	8,6	2,1	T-175-E	Range G1	Range G1	EG
CR212CN0080	390	8000	8,6	2,6	T-175-E	Range G1	Range G1	EG
CR212CN0100	470	10000	8,7	3,0	T-175-E	Range G1	Range G1	EG
CR212CN0150	700	15000	8,1	4,2	T-175-E	Range G1	Range G3	CA - CT
CR212CN0200	900	20000	8,2	5,2	T-175-E	Range G2	Range G3	CA - CT
CR212CN0240	1070	24000	8,1	6,0	T-175-E	Range G2	Range G3	CA - CT
CR212CN0350	1500	35000	8,5	8,7	T-175-E	Range G2	Range G3	CA - CT



THREADED STAINLESS STEEL 304 M77x2 or 2"1/2 BSP PLUG WITH 3 STAINLESS STEEL 316L U-SHAPED Ø10 ELEMENTS, WITH SHEATH FOR THERMOSTAT

Code (*)	L in mm	Watts	W/cm²	Weight in Kg	Electricfor's constructive thermic class	Connection box range		Thermostat range
						WITHOUT thermostat	WITH thermostat	
CR212I0030	315	3000	6,6	1,1	T-301-E	Range G1	Range G1	EG
CR212I0045	445	4500	6,5	1,3	T-301-E	Range G1	Range G1	EG
CR212I0060	589	6000	6,2	1,5	T-301-E	Range G1	Range G1	EG
CR212I0090	845	9000	6,3	2,1	T-301-E	Range G1	Range G1	EG
CR212I0120	1110	12000	6,4	2,9	T-301-E	Range G1	Range G3	CA - CT

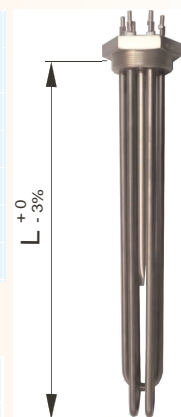

THREADED BRASS M77x2 or 2"1/2 BSP PLUG WITH 3 STEEL U-SHAPED Ø16 ELEMENTS, WITH SHEATH FOR THERMOSTAT

Code (*)	L in mm	Watts	W/cm²	Weight in Kg	Electricfor's constructive thermic class	Connection box range	Thermostat range
CR77CHA0060	980	6000	2,2	2,7	T-450-E	Range G1	EG



Standard voltage:
 1 Resistor: ~230 V
 3 Resistors: 3~230 V Δ 3~400 V Δ

GROUP 1 - Heating elements for immersion, accessories and tank heaters

1.5 - With Europa Range connection plug

EUROPA RANGE

Models according to catalogue: 733



General characteristics

- AISI 321 stainless steel tubular elements
- Stamped brass threaded heads
- Aluminium, adjustable-angle, connection box with IP-66 protection according to standard EN-60529. Supplied with all connection accessories, screws and thermostat connection.

Attention: Aluminium connection box and bulb thermostat are ordered separately. See page nº. 7

Note: If you need them we have solderable flanges, nuts and adaptors for these heating elements on page nº. 9 of the catalogue.

Code	L in mm	Watts	W/cm ²	Weight in Kg	Electricfor's constructive thermic class	Connection box range		Thermostat range
						WITHOUT thermostat	WITH thermostat	
CR212AC0010	290	1250	2,5	1,1	T-300-E	G1 Range	G1 Range	EG
CR212AC0022	450	2250	2,5	1,5	T-300-E	G1 Range	G1 Range	EG
CR212AC0030	565	3000	2,6	1,7	T-300-E	G1 Range	G1 Range	EG
CR212AC0045	840	4500	2,5	2,3	T-300-E	G1 Range	G1 Range	EG
CR212AC0060	1100	6000	2,5	3,2	T-300-E	G1 Range	G1 Range	EG
CR212AC0090	1500	9000	2,7	4,7	T-300-E	G1 Range	G1 Range	EG

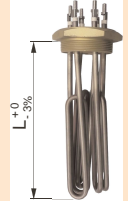
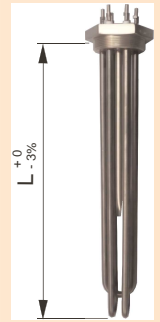

BRASS PLUG M77X2 THREAD OR 2"1/2 GAS THREAD WITH 3 "DL-HAIRPIN" Ø8 mm AISI321 HEATING ELEMENTS (WITHOUT THERMOSTAT SHEATH)

Code (*)	L in mm	Watts	W/cm ²	Weight in kg	Electricfor's constructive thermic class	Connection box range
CR212CIA2012	235	1200	2,2	0,75	T-300-E	G1 Range
CR77CIA2030	505	3000	2,2	1,90	T-300-E	G1 Range

GROUP 1 - Heating elements for immersion, accessories and tank heaters

1.6 - Accessories: Connection box

ALUMINIUM CONNECTION BOXES

P-M-G- RANGES

VALID FOR ALL DP – ED - ET - TIM and EUROPA HEATING ELEMENT RANGES.

- Aluminium, adjustable-angle, connection box with IP-66 protection according to standard EN-60529.
- Supplied with all connection accessories, screws and thermostat connection.
- Black oven-painted finish resistant to temperatures up to 220°C.
- The entire kit includes joints, screws, nuts, metal M25 or M32 stuffing box for power entry, metal M12 stuffing box for single-phase thermostat supply; and tightening discs needed for ensuring IP-66 level of protection against damp.

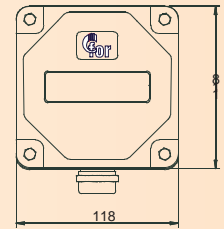
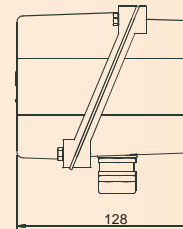

Connection box range	Code	Characteristics	Ready for:			Weight in Kg
			WITHOUT thermostat	Monophase thermostat	Triphase thermostat	
P1 Range	128088005	• For M45 and 1"1/2 • Maximum power: 10 KW • M25 Packing gland	X	---	---	0,95
P2 Range	128088006	• For M45 and 1"1/2 • Maximum power: 10 KW • M25 Packing gland	---	X (Ranges CA / CT) Only until 3,6 KW	X (Range EG)	0,95
M1 Range	128088007	• For 2" • Maximum power: 10 KW • M25 Packing gland	---	---	X (Range EG)	0,95
M2 Range	128088008	• For 2" • Power: 15 KW a 35 KW • M32 Packing gland	X	---	---	0,95
M3 Range	128088009	• For 2" • Power: 10 KW a 35 KW • M32 + M12 Packing gland	---	X (Ranges CA / CT)	---	1,0
G1 Range	128088010	• For M77 and 2"1/2 • Potencia máxima: 10 KW • M25 Packing gland	X	---	X (Range EG)	0,95
G2 Range	128088011	• For M77 and 2"1/2 • Potencia: 15 KW a 35 KW • M32 Packing gland	X	---	---	1,0
G3 Range	128088012	• For M77 and 2"1/2 • Potencia: 10 KW a 35 KW • M32 + M12 Packing gland	---	X (Range CA / CT)	---	1,0

P, D RANGE and

VALID FOR NA – OV - T – TIM AND CR45 EUROPA MODELS.
NOT SUITABLE FOR INCORPORATING BULB THERMOSTAT

- Aluminium, adjustable-angle, connection box with IP-66 protection according to standard EN-60529.
- Supplied with all connection accessories and screws
- The entire kit includes joints, screws, nuts, metal M20 stuffing box for power entry, and tightening discs needed for ensuring IP-66 level of protection against damp.

Connection box range	Code	Characteristics	Weight in Kg
Gama P	108050999	• For M45 and 1"1/2 • M20 Packing gland	0,35
Gama D	108050997	• For M45 and 1"1/2 • M20 Packing gland	0,35
Gama P3	128088013	• For 1"1/4 • M20 Packing gland	0,35

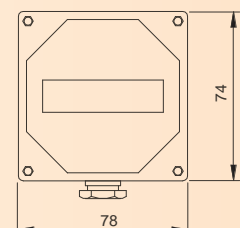
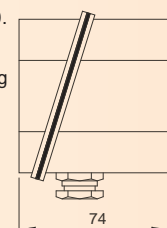

Single-pole bulb and capillary thermostats

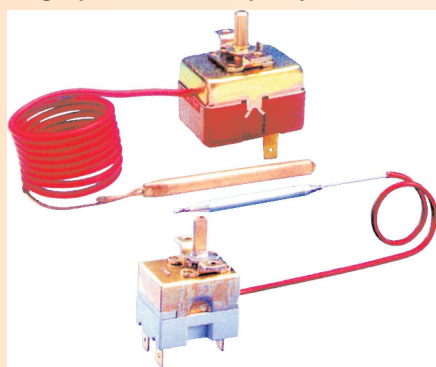

Bulb and capillary thermostats to include in the Europa Range

Single-pole snap action thermostats. 3 to 5 °C differential depending on temperate scales. Bulb and capillaries in copper up to 160°C, and in stainless steel for over 160°C. Connection to 6.3 mm fastons.

The thermostat units for each of the temperatures comprise the standard thermostat with its respective buttons, cover and connection screws.

Code	Thermostat range	Range	Characteristics	Max current (~240 V)	Weight in Kg
3509310324	CA	0 / 40 °C	Bulb in copper Ø6,5x142 mm Capillary 1m. 3 Faston	16 A	0,11
3509310320	CA	0 / 90 °C	Bulb in copper Ø6,5x66 mm Capillary 1m. 3 Faston	16 A	0,11
3509310321	CA	0 / 120 °C	Bulb in copper Ø6,5x66 mm Capillary 1m with PVC sheet. 3 Faston	16 A	0,11
3509310321/ESP	CA	0 / 120 °C	Bulb in copper Ø6,5x66 mm Capillary 1m. 3 Faston	16 A	0,11
3509310322	CA	0 / 200 °C	Bulb in S. Steel Ø5x98 mm Capillary 1m. 3 Faston	16 A	0,11
3509310322/ESP	CA	0 / 200 °C	Bulb in S. Steel Ø5x98 mm Capillary 1m with silicone sheet. 3 Faston	16 A	0,11
3509310323	CA	0 / 320 °C	Bulb in S. Steel Ø3x195 mm Capillary 1m. 3 Faston	16 A	0,11
517350000	CT1	0 / 90 °C	Bulb in copper Ø6x99 mm Capillary 1m. 2 Faston	20 A	0,06
517355000	Button + Face plate 0 / 90 °C				0,01
517352000	CT2	30 / 160 °C	Bulb in copper Ø6x88 mm Capillary 1m. 2 Faston	20 A	0,06
517357000	Button + Face plate 30 / 160 °C				0,01
517377000	TE	120 °C	Manual reset thermostat. Capillary 1m. Bulb in S. Steel Ø6x72 With M9x1 gland	16 A	0,12
517578000	TC	65 °C	Capillary 1m. Bulb in S. Steel Ø6x72 With M9x1 gland	16 A	0,12

NON-pluggable cane thermostats



Bulb and capillary thermostats to include in the Europa Range

Three-pole snap action thermostats. 2 to 13°C differential depending on temperate scales. Bulb and capillaries in stainless steel. Connection to 6.3mm fastons.

Code	Thermostat range	Range	Characteristics	MAximum intensity (~240 V)	Weight in Kg
517370000	EG	1 / 40 °C	Bulb in copper Ø6x215 mm Capillary 880 mm	16 A	0,19
517370001	Botón escala 0 / 40 °C				0,02
517371000	EG	28 / 85 °C	Bulb in copper Ø6x129 mm Capillary 880 mm	16 A	0,19
517371001	Botón escala 30 / 85 °C				0,02
517372000	EG	36 / 125 °C	Bulb in copper Ø6x138 mm Capillary 880 mm	16 A	0,19
517372001	Botón escala 30 / 120 °C				0,02
517373000	EG	60 / 200 °C	Bulb in S. Steel Ø6x142 mm Capillary 880 mm	16 A	0,19
517373001	Button scale 60 / 200 °C				0,02
517374000	EG	50 / 300 °C	Bulb in S. Steel Ø6x77 mm Capillary 880 mm	16 A	0,19
517374001	Button scale 50 / 300 °C				0,02

Rod thermostats



Single-pole rod thermostats. 5 to 10°C differential depending on temperature scales. Connection by leads through side inputs.

Code	Description	Thermostat range	Operation temperatures		Characteristics	Maximum current (~240 V)
			Control (Automatic reset)	Safety (Manual reset)		
517330000	TER-CO-165-0-80-NEF	NEF	0 / 80 °C	---	Sheath Ø7,5x165 mm	20 A
517335000	TER-CO-265-5-80-NEF	NEF	5 / 80 °C	---	Sheath Ø7,5x265 mm	20 A
517337000	TER-CO-265-45-120-NEF	NEF	45 / 120 °C	---	Sheath Ø7,5x265 mm	20 A
517358000	TER-CO-165-0-73-87-NEF	NEF	-10 / 73 °C	87 °C	Sheath Ø7,5x165 mm	20 A
517347000	TER-SV-280-45-95-NEF	NEF	---	45 / 95 °C	Sheath Ø7,5x280 mm	16 A

ACCESSORIES FOR THERMOSTATS

Code	Description
570004330	Mounting clip for bulb thermostat Ø _{nominal} 7,5 mm to sheath Ø _{int} 3,5 to 8 mm
570004331	Mounting clip for bulb thermostat Ø _{nominal} 6 mm to sheath Ø _{int} 3,5 to 7 mm
570004332	Mounting clip for bulb thermostat Ø _{nominal} 8 mm to sheath Ø _{int} 3,5 to 12 mm



GROUP 1 - Immersion heaters and accessories

- 1.7 - Accessories: Weldable flanges
- 1.8 - Accessories: Nut
- 1.8 - Accessories: Threaded adapters
- 1.10 - Accessories: Gaskets

WELDABLE FLANGES / NUTS /
ADAPTERS / GASKETS

WELDABLE FLANGES

Code	Dimensions in mm		Thread	Material	Weight in Kg
	ØA	ØB			
106073000	70	60	M45	SS. 304	0,35
106071000	108	90	M77	SS. 304	0,60
106077000	65	54	1 1/4"	SS. 304	0,27
106075000	70	60	1 1/2"	SS. 304	0,28
106081000	93	75	2"	SS. 304	0,54
106079000	108	90	2 1/2"	SS. 304	,064
106072002	70	60	M45	Steel	0,31
106070002	108	90	M77	Steel	0,57
106076002	65	54	1 1/4"	Steel	0,26
106074002	70	60	1 1/2"	Steel	0,27
106080002	93	75	2"	Steel	0,53
106078002	108	90	2 1/2"	Steel	0,60

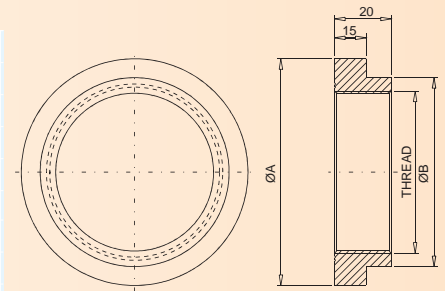

NUTS

Code	Dimensions in mm				Thread	Material	Weight in Kg
	A	B	C	Ø D			
106065000	60	7,5	-	-	M45	SS. 304	0,15
106083000	95	10	-	-	M77	SS. 304	0,27
106096000	55	7,5	-	-	1 1/4"	SS. 304	0,11
106068000	60	7,5	-	-	1 1/2"	SS. 304	0,13
106102000	85	10	-	-	2"	SS. 304	0,20
106099000	95	10	-	-	2 1/2"	SS. 304	0,28
106066002	60	7,5	-	-	M45	Steel	0,12
106084002	95	10	-	-	M77	Steel	0,24
106097000	55	7,5	-	-	1 1/4"	Steel	0,08
106069002	60	7,5	-	-	1 1/2"	Steel	0,12
106103000	85	10	-	-	2"	Steel	0,26
106100002	95	10	-	-	2 1/2"	Steel	0,24
106005000	28,7	7,3	5	35,4	3/4"	Brass	0,02
106007000	35,8	7,8	5	45,1	1"	Brass	0,02
106008000	44,8	8,2	5	55,9	1 1/4"	Brass	0,03
106064000	60	7,5	-	-	M45	Brass	0,08
106009000	60	7,5	-	-	1 1/2"	Brass	0,05
106010000	65	9	6	86,6	2"	Brass	0,12
106011000	90,8	11,5	9	112,2	2 1/2"	Brass	0,25

BRASS

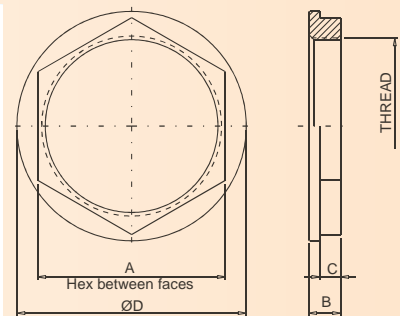

SS AISI 304 / STEEL

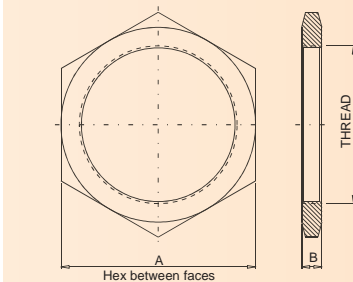

THREADED BRASS ADAPTERS

Code	Dimensions in mm			BSP Thread		Weight in Kg
	A	B	C	Male	Female	
106090000	57	25	10	R 1 1/2"	R 1 1/4"	0,12
106091000	75	27	10	R 2"	R 1 1/4"	0,43
106093000	88	28	10	R 2 1/2"	R 2"	0,51

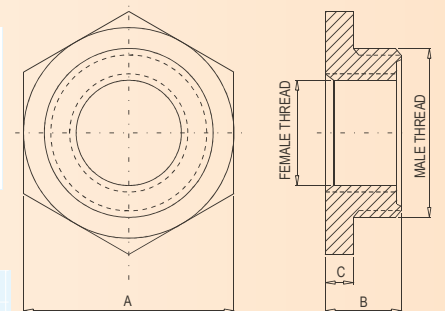

GASKETS

Code	Thread for	Material
107058000	ACL-CAL (Electric boiler flange P-EB-110)	Basic
107097000	3/4"	Basic
107095000	1"	Basic
107031000	1 1/4"	Rubber
107042000		Basic
107072000	1 1/2"	Basic
107032000	2"	Rubber
107050000		Basic
107075000	2 1/2" and M77x2	Rubber
107076000		Basic
107069000	M45x2	Rubber
107070000		Basic

BASIC: basic composition rubber NBR + Fibers of aramide (asbestos free)





Novatec Premium II

Premium II Novatec material is composed of compressed graphite, Kevlar® fibers and a low percentage of high quality NBR. Their excellent chemical and thermal resistance, high stability and low permeability to gases allows to replace the graphite materials reinforced with steel (fragile and difficult to work) in situations previously unthinkable for compressed fiber gaskets. With Novatec Premium II you can cover 80% of the different applications available in the industry.

Material characteristics

- NBR Binder
- Approvals DVGW-HTB-KTW-WRC-BAM (130 bar/80°C)
- Jacket Color: Blue Purple

- Marked Frenzelit on honeycomb
- A310-stick coating on both sides
- Available thickness: 1 - 1.5 - 2 - 3 mm
- Tolerance of thickness < 1 mm.: ±0.1 mm. > 1 mm.: ± 0.2 mm.

Recommended Application Limits

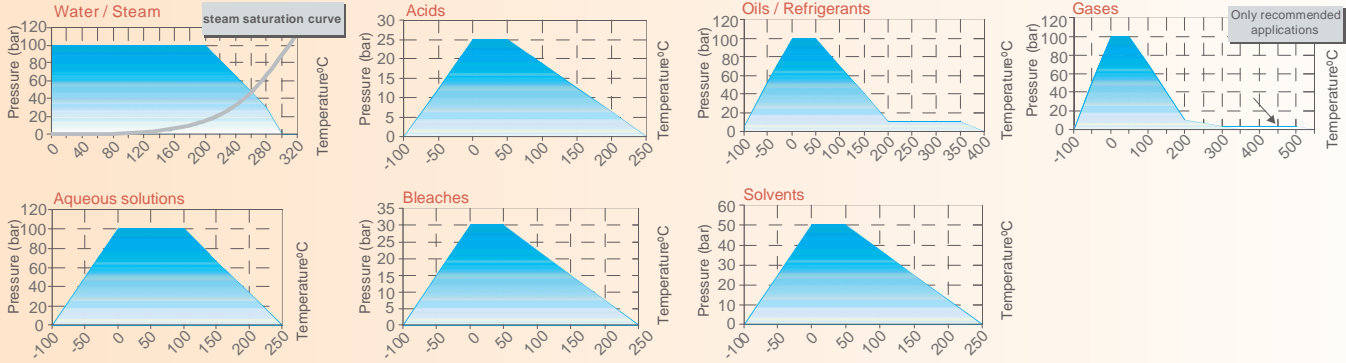

Novapress Basic

Mixture composed of aramid fibers, special materials filler and NBR rubber.

Material characteristics

- NBR Binder
- Approvals DVGW-HTB-KTW
- Jacket Color: Orange
- Marked Frenzelit on honeycomb

- A300-stick coating on one side
- Maximum continuous temperature: 120 °C
- Available thickness: 0.3 - 0.5 - 0.75 - 1 - 1.5 - 2 - 3 - 4 mm
- Peak temperature: 250 °C

Recommended Application Limits

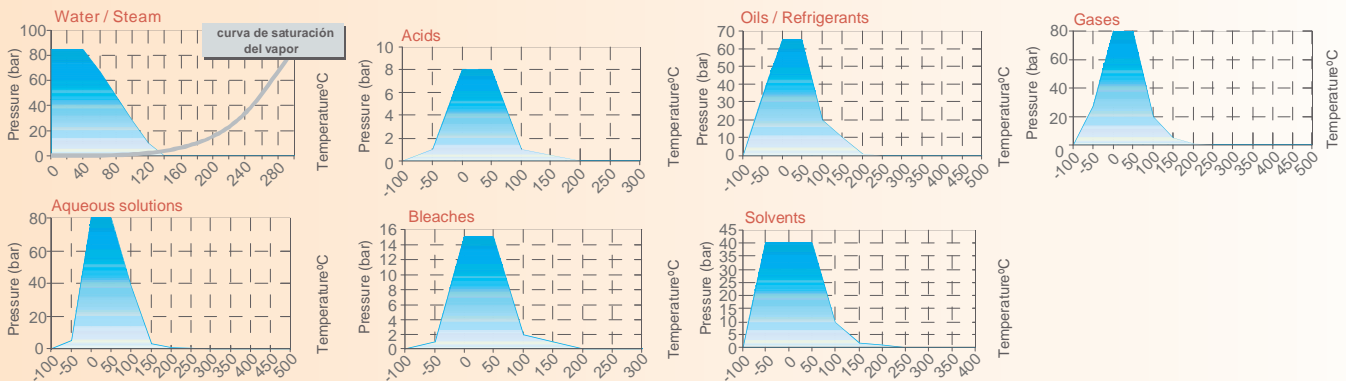

NOTA: Other materials and dimensions for standardized flanges and special flanges. Please contact our Technical Sales Department

Standard dimensions

NOTA: The standard thickness for joints is 2mm.

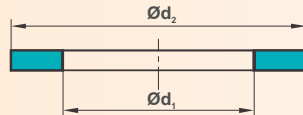

According to DIN2690 for RF flanges

DN	Dimensions in mm					
	Ød1	PN6	PN10	PN16	PN25	PN40
40	49	85	92	92	92	92
50	61	95	107	107	107	107
65	77	115	127	127	127	127
80	90	132	142	142	142	142
100	115	152	162	162	168	168
125	141	182	192	192	195	195
150	169	207	218	218	225	225
175	195	237	248	248	255	267
200	220	262	273	273	285	292
250	274	318	328	330	342	353
300	325	373	378	385	402	418
350	368	423	438	445	458	475
400	420	473	490	497	515	547

According to ANSI B16.21 for ANSI B16.5 RF flanges

DN	Dimensions in mm						
	Ød1	150# (PN20)	300# (PN50)	400# (PN68)	600# (PN100)	900# (PN150)	1500# (PN250)
¾"	27	57	67	67	67	70	70
1"	33	67	73	73	73	79	79
1 ¼"	42	76	82	82	82	88	88
1 ½"	48	86	95	95	95	98	98
2"	60	105	111	111	111	142	142
2 ½"	73	124	130	130	130	165	165
3"	89	136	149	149	149	168	174
3 ½"	102	161	165	161	161		
4"	114	174	181	178	194	206	209
5"	141	196	210	213	241	247	254
6"	168	222	250	247	266	288	282
8"	219	279	308	305	320	358	352
10"	273	340	362	359	400	434	434
12"	324	410	422	419	457	498	520
14"	356	451	486	483	492	520	577
16"	406	514	540	537	565	574	641



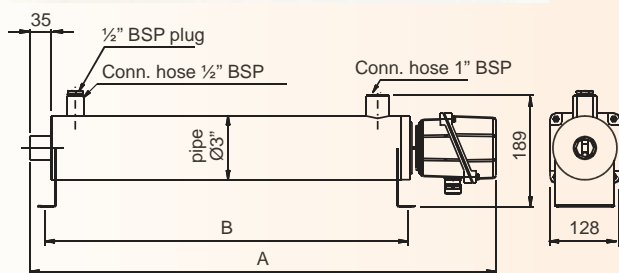

General characteristics

- Tubular elements in AISI 316L stainless steel, AISI 321 stainless steel or nickel-plated copper.
- Recipient of 3" in diameter in St37 steel, with an outer layer of anticorrosive paint
- Circuit input/output connection hoses of 1" female gas thread.
- Threaded heads of stamped brass or AISI 304 stainless steel.
- All models include a sheath of the same material as the heating element pipe, and a bulb thermostat with automatic reset, regulating scales 0/90°C; 30/85°C or 36/125°C according to models.
- Adjustable aluminium connection box, with IP-66 protection according to standard EN-60529.
- It is supplied with all accessories for connection, attachment and connection of the thermostat.
- All models include a 1/2" female gas thread hose for attaching a temperature probe (Not included)
- GCP-TR in line heaters are designed for working at a maximum design pressure of 6 bar and maximum design temperature indicated according to models.
- Optionally, together with the GCP-TR heater unit we can provide the switchboard with all the components and protections needed for its connection: heat-controllers, buttons, contactors, differential, magneto-thermal, etc.
- Standardised current 3~230 V Δ, 3~400 V ▲
- To order, made to measure heating elements can be manufactured according to your specifications:
 - Tubular elements in: AISI 316L, Incoloy®-800 e Incoloy®-825 and Titanium
 - Stainless steel or Titanium heads.
- Units according to Para. 3 Art. 3 of the Pressurised Units Directive 97/23 CE.

Standardised GCB-TR-AC models, range for heating oil, with AISI 321 stainless steel tube heating elements. Design temperature 125 °C

Code		Watts	W/cm ²	Thermostat range	I/O Sleeve	Dimensions in mm	
Steel St 37.0 vessel	Stainless steel AISI 316L vessel					A	B
GCP-TR-AC0010	GCP-TR-INOX-AC0010	1250	2,5	36 / 125 °C	1" Gas-H	565	390
GCP-TR-AC0022	GCP-TR-INOX-AC0022	2250	2,5	36 / 125 °C	1" Gas-H	665	490
GCP-TR-AC0030	GCP-TR-INOX-AC0030	3000	2,6	36 / 125 °C	1" Gas-H	790	615
GCP-TR-AC0045	GCP-TR-INOX-AC0045	4500	2,5	36 / 125 °C	1" Gas-H	1100	925
GCP-TR-AC0060	GCP-TR-INOX-AC0060	6000	2,5	36 / 125 °C	1" Gas-H	1315	1140
GCP-TR-AC0090	GCP-TR-INOX-AC0090	9000	2,7	36 / 125 °C	1" Gas-H	1715	1540

For heating element spares, please consult our Europa Range heating elements, models CR212AC

Standardised GCB-TR-CN models, range for heating water, with nickel-plated copper tube heating elements. Design temperature 90 °C

Code	Watts	W/cm ²	Thermostat range	I/O Sleeve	Dimensions in mm	
Steel St 37.0 vessel					A	B
GCP-TR-CN0040	4000	8,7	30 / 85 °C	1" Gas-H	565	390
GCP-TR-CN0060	6000	8,6	30 / 85 °C	1" Gas-H	565	390
GCP-TR-CN0080	8000	8,6	30 / 85 °C	1" Gas-H	665	490
GCP-TR-CN0100	10000	8,7	30 / 85 °C	1" Gas-H	665	490
GCP-TR-CN0150	15000	8,1	0 / 90 °C	1" Gas-H	1100	925
GCP-TR-CN0200	20000	8,2	0 / 90 °C	1" Gas-H	1100	925
GCP-TR-CN0240	24000	8,1	0 / 90 °C	1" Gas-H	1315	1140
GCP-TR-CN0350	35000	8,5	0 / 90 °C	1" Gas-H	1715	1540

For heating element spares, please consult our Europa Range heating elements, models CR212CN

Standardised GCB-TR-II models, range for heating water or other fluids, with AISI 316L stainless steel tube heating elements. Design temperature 90 °C

Code		Watts	W/cm ²	Thermostat range	I/O Sleeve	Dimensions in mm	
Steel St 37.0 vessel	Stainless steel AISI 316L vessel					A	B
GCP-TR-II0030	GCP-TR-INOX-II0030	3000	6,6	30 / 85 °C	1" Gas-H	565	390
GCP-TR-II0045	GCP-TR-INOX-II0045	4500	6,5	30 / 85 °C	1" Gas-H	665	490
GCP-TR-II0060	GCP-TR-INOX-II0060	6000	6,2	30 / 85 °C	1" Gas-H	790	615
GCP-TR-II0090	GCP-TR-INOX-II0090	9000	6,3	30 / 85 °C	1" Gas-H	1100	925
GCP-TR-II0120	GCP-TR-INOX-II0120	12000	6,4	0 / 90 °C	1" Gas-H	1315	1140

For heating element spares, please consult our Europa Range heating elements, models CR212II

IMPORTANT NOTE: For a fluid exit temperature > 60 °C, fireproofing of the in line heater is obligatory. If you so wish, we can supply your GCP-TR in line heating unit completely fireproofed with elastomer foam. For this purpose, please add CAL to the code on your order.

Example: 6000 W in line heating unit for oil with fireproofed recipient, model **GCP-TR-AC0060- CAL**



ECU

Models as per catalogue: NTC-9604

GROUP 11 - Immersion heaters, drums, heaters and accessories

1.11 - Heaters for knife sterilizers

THERMOSTATIC HEATER ASSEMBLY FOR KNIFE STERILIZERS OR OTHER INSTRUMENTS

General characteristics

- Tubular element of stainless steel AISI 316L of Ø8 mm
- BSP threaded plug of stamped brass
- Steel painted connection box with degree protection against moisture IP-66.
- Stuffing box
- Watertightness gasket
- Welded with silver alloy for stainless steel tube
- Standard voltage ~230 V
- Sheath with manual reset safety thermostat of 105 ± 4 °C. Differential 20 ± 10 °C.
- Sheath with automatic reset control thermostat of 93 ± 3 °C. Differential 6 ± 2 °C.
- On demand, special heating elements can be made according to your specifications:
 - Material tube: AISI 316L, Incoloy®-800, Incoloy®-825 and Titanium
 - Stainless steel or titanium BSP threaded plugs.

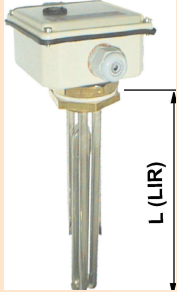

Code	L (LIR) in mm	Thread	Watts	W/cm ²	Tube material	Electricfor's construct. thermic class	Weight in Kg
ECU1	190	M45	1000	6,9	Ø 8 AISI 316L	T-301-E	1,1
ECU2	190	1 1/4"	1000	6,9	Ø 8 AISI 316L	T-301-E	1,1

Note: The complete set of heating element, connection box, thermostats, lock nut and klingerit joint is included in the price.

Usual applications: Especially appropriate for knife sterilizers in refrigerated slaughterhouses.

It may also be used for other applications such as heating slightly salted waters, or with low chlorine content, neutral or marginally basic pH, high oxygen content, etc., for which the most suitable sheath material for the element is 316L stainless steel, or when airtightness is required in the connection box, or double safety in the temperature control. In case of doubt, please consult NTT n°4101 or else our Technical Department.

SPARE PARTS FOR KNIFE STERILIZERS ECU

Code	Spare part for	L (LIR) in mm	Thread	Watts	W/cm ²	Tube material	Electricfor's constructive thermic class	Weight in Kg
RECU1	ECU1	190	M45	1000	6,9	Ø 8 SS 316L	T-301-E	0,7
RECU2	ECU2	190	1 1/4"	1000	6,9	Ø 8 SS 316L	T-301-E	0,7

SPARE THERMOSTATS FOR THERMOSTATIC HEATER ASSEMBLY ECU

Description	Code	Thermostat range	Range	Reset	Max. current	Capillary length	Bulb		Weight in Kg
							Material	Dimensions	
TER-BU-90-AUT-ECU	517105000	ECU	93 °C	Automatic	10A (~250 V)	180	Copper	Ø6 x 102 mm	0,75
TER-BU-105-MAN-ECU	517106000	ECU	104 °	Manual	10A (~250 V)	180	Copper	Ø6 x 102 mm	0,75

NOB

Models as per catalogue: 733 / NTC-8750

GROUP 11 - Immersion heaters, drums, heaters and accessories

1.12 - With coupling plug and sheath for thermostat

MONOBLOCK GROUP OF HEATING ELEMENT WITH SHEATH FOR THERMOSTAT WITH BRASS 1 1/4 BSP COUPLING PLUG

General characteristics

- Tubular element of stainless steel AISI 321, AISI 316L or nickel-plate copper of Ø8 mm, according models.
- BSP threaded plug of stamped brass
- Protection hood IP-40
- Welded with silver alloy for stainless steel tube.
- Sheath for rod thermostat connectable to heating element.
- Standard voltage ~230 V



RANGE FOR WATER OR HIGH QUALITY THERMAL OIL

Code	L (LIR) in mm	Watts	W/cm ²	Thermostat range according to appl.		Shape	Tube material	Electricfor's constructive thermic class	Weight in Kg
				Water	Oil				
NOB11	135	500	5,3	A1	A2	VD	AISI 321 or 304L	T-300-E	0,23
NOB12	150	750	7,7	A1	A2	VD	AISI 321 or 304L	T-300-E	0,24
NOB13	315	1000	7,9	B1	B2	U	AISI 321 or 304L	T-300-E	0,27
NOB14	315	1500	7,5	B1	B2	1/2 VD	AISI 321 or 304L	T-300-E	0,34
NOB15	315	2000	7,8	B1	B2	VD	AISI 321 or 304L	T-300-E	0,38
NOB16	285	2500	7,6	B1	B2	TVC	AISI 316L	T-301-E	0,45
NOB17	325	3000	7,8	B1	B2	TVC	AISI 316L	T-301-E	0,50
NOB18	375	3500	7,7	B1	B2	TVC	AISI 316L	T-301-E	0,58
NOB21	300	1000	8,3	B1	-	U	Nickel copper	T-175-E	0,28
NOB23	290	1500	7,7	B1	-	1/2 VD	Nickel copper	T-175-E	0,35
NOB24	330	2000	9,3	B1	-	1/2 VD	Nickel copper	T-175-E	0,38
NOB25	450	1500	7,3	B1	-	U	Nickel copper	T-175-E	0,34

L = Maximum length (sheath or resistor) including thread.

Dimensional tolerances for element shape:

"U" = $\begin{matrix} +0 \\ -3\% \end{matrix}$

"1/2 VD" - "VD" - "TVC" - "CVC" = IT15

RECOMMENDATIONS

- To heat water **don't** use the A2 and B2 thermostat range. (Scale 30-150 °C).
- To heat thermal oil of high quality or high velocity of movement **don't** use heating elements in copper or nicked copper tube. The corrosive effect of the oil over the copper may seriously damage the life of the heating element.



Code: CNOB

PROTECTION ACCESSORIES AND PROTECTION HOOD

Degree protection against moisture IP40



GROUP 1 - Immersion heaters, drum heaters and accessories

1.12 - With round flange and sheath for thermostat

MONOBLOCK GROUP OF HEATING ELEMENT WITH SHEATH FOR THERMOSTAT WITH BRASS 1 1/4 BSP COUPLING PLUG. RANGE FOR OIL

General characteristics

- Tubular element of stainless steel AISI 321, AISI 316L or nickel-plate copper of Ø8 mm, according models.
- BSP threaded plug of stamped brass
- Protection hood IP-40
- Welded with silver alloy for stainless steel tube.
- Sheath for rod thermostat connectable to heating element.
- Standard voltage ~230 V

Code	L (LIR) in mm	Watts	W/cm ²	Thermostat range	Shape	Tube material	Electricfor's constructive thermic class	Weight in Kg
NOB3	315	1000	4	B1 - B2	VD	AISI 321 or 304L	T-300-E	0,39
NOB5	450	1500	3,9	B1 - B2	VD	AISI 321 or 304L	T-300-E	0,50
NOB7	420	2000	3,9	B1 - B2	TVC	AISI 321 or 304L	T-300-E	0,63
NOB30	450	2500	3,3	B1 - B2	CVC	AISI 321 or 304L	T-300-E	0,80
NOB32	530	3000	3,3	B1 - B2	CVC	AISI 321 or 304L	T-300-E	0,95



L = Maximum length (sheath or resistor)

Dimensional tolerances for element shape according to IT-15

ECU

Models as per catalogue: NTC-9604

GROUP 1 - Immersion heaters, drum heaters and accessories

1.13 - With round flange and sheath for thermostat

MONOBLOCK GROUP OF HEATING ELEMENT WITH Ø48 mm ROUND BRASS FLANGE AND SHEATH FOR THERMOSTAT

General characteristics

- Tubular element of copper of Ø8 mm
- Ø48 mm round stamped brass flange
- Sheath for rod thermostat connectable to heating element.
- Standard voltage ~230 V

RANGE FOR WATER

Code	Dimensions in mm		Watts	W/cm ²	Thermostat range	Shape	Tube material	Electricfor's constructive thermic class	Weight in Kg
	L (LLLP)	A							
PNOB12AR	280	200	1500	10,9	E1-E3	VD	Copper	T-175-E	0,21

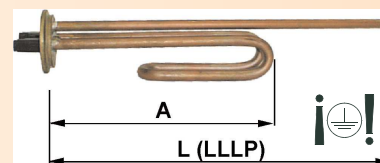

L = Maximum length (sheath or resistor)
Dimensional tolerances for element shape: "1/2 VD" = ± 2 mm.

ECU

Models as per catalogue: NTC-9604

GROUP 1 - Immersion heaters, drum heaters and accessories

1.14 - Steatite mounted heating elements

MONOBLOCK GROUP OF HEATING ELEMENT WITH BRASS 1 1/4 BSP COUPLING PLUG AND SHEATH FOR THERMOSTAT. SUITABLE FOR CONNECTING ADJUSTABLE ALUMINUM COUPLING BOX IP-66

General characteristics

- Tubular element of stainless steel AISI 321 or AISI 316L of Ø8 mm, according models
- BSP threaded plug of stamped brass
- Adjustable connection box with degree protection against moisture IP-66
- Welded with silver alloy for stainless steel tube.
- Sheath for rod thermostat connectable to heating element.
- Standard voltage ~230 V

RANGE FOR WATER OR HIGH QUALITY THERMAL OIL

Code	L (LIR) in mm	Watts	W/cm ²	Thermostat range According to application		Shape	Tube material	Electricfor's constructive thermic class	Weight in Kg
				Water	Oil				
NOB19CH	425	4000	7,6	CT1	CT2	TVC	AISI 316L	T-301-E	0,80

RANGE FOR OIL

Code	L (LIR) en mm	Watts	W/cm ²	Thermostat range	Shape	Tube material	Electricfor's constructive thermic class	Weight in Kg
NOB36CH	680	4000	3	CT2	CVC	AISI 321 or 304L	T-300-E	1,35

NOTE: The complete set is made up of element + adjustable aluminum coupling box + bulb thermostat range CT1 or CT2. The aluminum coupling box, as well as the bulb thermostat are not included in the price

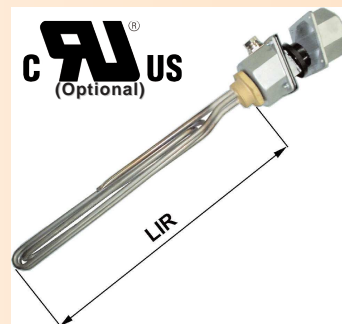

NOB

Models as per catalogue: 733, NTC-8750

C-HER-TER-MO RANGE SUITABLE FOR THERMOSTAT BULB

Code	Dimensions in mm			Weight in Kg
	A	B	C	
108072000	78	74	98	0,41

The complete set includes the joints, screws, nuts, flange attachment to bulb thermostat, metallic packing glands M20 for voltage supply and tightening disc necessary to assure the degree protection against moisture IP-66

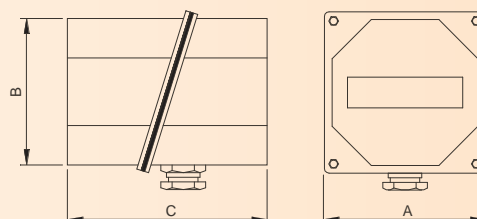

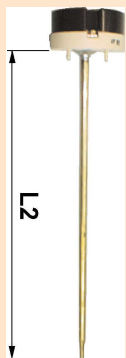

Description	Code	Thermostat range	Range	Max. current	L2 mm	Connection to element	Mains connection	Weight in Kg
TER-CO-137-0-90-F	517321000	A1	0-90	16 A	137	Faston 6,3	Barrilete	0,06
TER-CO-137-40-150-F	517323000	A2	40-150	16 A	137	Faston 6,3	Barrilete	0,06
TER-CO-270-30-90-F	517320000	B1	30-90	16 A	270	Faston 6,3	Barrilete	0,08
TER-CO-270-90-150-F	517322000	B2	90-150	16 A	270	Faston 6,3	Barrilete	0,08
TER-CO-280-10-80	517277000	E1	10-80	16 A	270	Faston 6,3	Barrilete	0,05
TER-AR-280-20-80-F	517311000	E3	20-80	15 A	280	Faston 6,3	Barrilete	0,05

Note 1: The thermostats of the "A" range may replace those of the "B" range, but they have a higher differential and lower accuracy.

Note 2: For water it is recommendable to use the thermostat up to 90 °C to avoid risk of accidental boiling.

BULB THERMOSTATS FOR NOB19CH and NOB36CH MODELS

Description	Code	Thermostat range	Range	Max. current	Capillary length	Bulb		Weight in Kg
						Material	Dimensions	
TER-BU-CT-0-90	517350000	CT1	0-90	20 A	1000	Copper	Ø6x65 mm	0,06
Button 0/90 + Black face plate	517355000	CT1	0-90	-	-	-	-	0,01
TER-BU-CT-30-160	517352000	CT2	30-160	20 A	1000	Copper	Ø6x65 mm	0,06
Button 30/160 + Black face plate	517357000	CT2	30-160	-	-	-	-	0,01

ACCESSORIES FOR BULB THERMOSTAT

Code	Description
570004330	Mounting dip for bulb thermostat Ø _{nominal} 7,5 mm to sheath Ø _{int} 3,5 to 8 mm
570004331	Mounting dip for bulb thermostat Ø _{nominal} 6 mm to sheath Ø _{int} 3,5 to 7 mm
570004332	Mounting dip for bulb thermostat Ø _{nominal} 8 mm to sheath Ø _{int} 3,5 to 12 mm

CT / BT

Models as per catalogue: NTC-8710

GROUP 1 - Immersion heaters, drums, heaters and accessories

1.15 - Steatite mounted heating elements

STEATITE-MOUNTED HEATING ELEMENTS

SINGLE VOLTAGE "CT" RANGE and DUAL VOLTAGE "BT" RANGE

Steatite-mounted elements work inserted inside a sheath that in turn is in contact with the liquid to be heated. They are made both for household as well as for industrial use

General characteristics

- Resistive wire of Nickel-Chrome alloy
- Easy to replace spare parts
- High-quality ceramic support
- On order, other diameters, lengths, power and voltages, both in mono-, two- and three-phase



SINGLE VOLTAGE "CT" RANGE

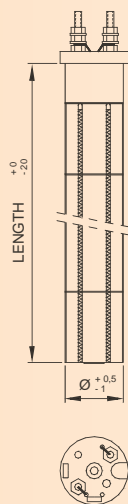

Code	Watts	ØxLength in mm.	Weight in Kg
CT002	600	20 x 220	0,07
CT003	750	20 x 270	0,07
CT004	850	20 x 320	0,09
CT006	750	20 x 255	0,09
CT007	750	20 x 265	0,09
CT009	850	20 x 370	0,20
CT013	600	29 x 175	0,18
CT014	750	29 x 175	0,22
CT015	750	29 x 260	0,25
CT016	1000	29 x 260	0,25
CT017	1000	29 x 325	0,30
CT026	1500	29 x 325	0,30
CT018	1000	29 x 375	0,31
CT019	1500	29 X 525	0,45
CT020	2000	29 X 625	0,55
CT021	2000	29 x 725	0,65
CT022	800	38 x 225	0,42
CT023	1000	38 x 275	0,45
CT024	1000	38 X 325	0,50
CT025	1000	38 X 375	0,56

SINGLE VOLTAGE, 2 TERMINALS, Voltage~230V

DUAL VOLTAGE "BT" RANGE

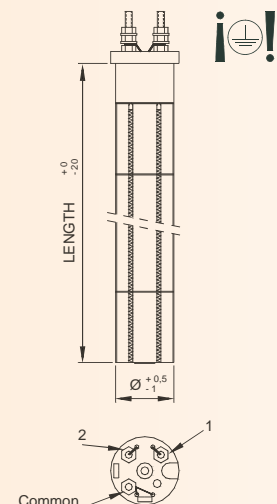

Code	Watts	ØxLength in mm.	Weight in Kg
BT008	800	29 x 175	0,15
BT009	900	29 x 225	0,20
BT001	1000	29 x 275	0,25
BT002	1000	29 x 325	0,30
BT003	1000	29 x 375	0,34
BT004	1500	29 x 375	0,34
BT005	1500	29 x 525	0,45
BT006	2000	29 x 625	0,50
BT010	1300	31 x 325	0,40
BT011	1500	31 x 325	0,40
BT007	1000	38 x 325	0,50
BT012	1000	48 x 275	0,68
BT013	1500	48 x 370	0,86

DUAL VOLTAGE, 3 TERMINALS, Voltage ~ 115/230 V

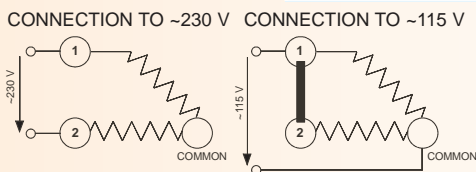

Connect to a ~230 V line through the terminal 1 and 2. Join terminals 1 and 2, and connect to a ~115 V line through the common terminal and one of the other two joined terminals.



HEATING ELEMENTS FOR ELECTRIC BOILERS

General characteristics

- Tubular elements of nickel-plate copper, insulated with electromelted and lamination-compressed magnesium oxide.
- Double-drawn plates of stainless steel plate or copper plated steel with coating of polyurethane acrylic resin primer. Also we can supply with brass or stainless steel threaded plugs or other type of plates in addition to those standardized by Electricfor.
- Silver alloy welds.
- M4 stainless terminals.
- All models with M5 terminal welded to plate for earth connection.
- Two sheaths of 217 mm usable length with Øint 8,5 mm for bulb thermostats or temperature sensors.
- The bunch of elements passes through Ø70 mm.
- The heating element is given a general finish of copper or nickel plating. The respective bridges, washers and nuts are supplied with each heating element.
- For specially hard water facilities, acid or alkaline they can be made in stainless steel tube AISI 321, AISI 316L or Incoloy®-825.

Usual applications

- In all facilities in which water is heated in a closed circuit to a maximum of 90 °C with a built-in acceleration pump.
- Electric boilers, auxiliary circuits for tap water, auxiliary circuits for bathrooms, etc.



Code	Watts	W per element	W/cm²	Nº elements	Dimensions in mm		Shape	Electricfor's constructive thermic class	Weight in Kg
					A	B			
CALEB4,5	4500	750	11	6	200	-	U	T-175-E	0,89
CALEB6	6000	1000	11	6	250	-	U	T-175-E	1,0
CALEB7,5	7500	1250	10	6	305	-	U	T-175-E	1,1
CALEB9	9000	1500	10	6	360	-	U	T-175-E	1,3
CALEB10,5	10500	1750	9,5	6	320	115	VD	T-175-E	1,5
CALEB12	12000	2000	9,4	6	375	115	VD	T-175-E	1,7
CALEB13,5	13500	2250	9,4	6	375	170	VD	T-175-E	1,8
CALEB15	15000	2500	9,3	6	375	230	VD	T-175-E	1,9
CALEB18	18000	3000	9,4	6	375	335	VD	T-175-E	2,2
* CALEB21	21000	2500	11	6	375	335	VD	T-175-E	2,2
* CALEB24	24000	4000	12	6	375	335	VD	T-175-E	2,2

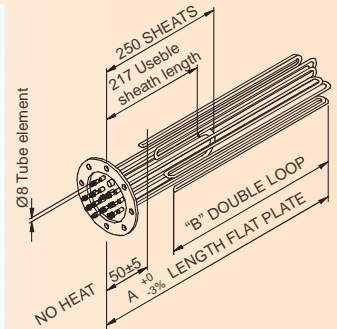

Standard Voltage 3~230 V Δ, 3~400 V

(*) **Attention:** DO NOT USE THESE MODELS UNLESS THERE IS A LARGE FLOW OF LIQUID. CONSULT OUR TECHNICAL-COMMERCIAL DEPARTMENT.

STANDARD PLATE FOR ELECTRIC BOILER HEATING ELEMENTS

Model	Code	Dimensions in mm.						Nº of boreholes coupling	Material
		D	K	G	d	b	f		
P-EB-110	111033230	110	97	71	9	7	2,5	8	Stainless Steel

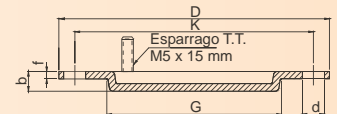

GASKETS FOR ELECTRIC BOILER HEATING ELEMENTS

Code	Description	Material
107058000	ACL-CALD	BASIC (asbestos free)

GROUP 1 - Immersion heaters, drum heaters and accessories

SEVEN LOOP U-SHAPED HEATING ELEMENT WITH COUPLING CONNECTORS

General characteristics

- Tubular elements of nickel-plate copper, insulated with electromelted and lamination-compressed magnesium oxide
- M12 brass connectors, welded to the tube with silver alloy.
- Standard Voltage ~230 V

Code	L in mm	Threas	Watts	W/cm²	Tube material	Electricfor's construct. thermic class	Weight in Kg
7V001C	170	M12	3.000	5,9	Cobre	T-175-E	0,50

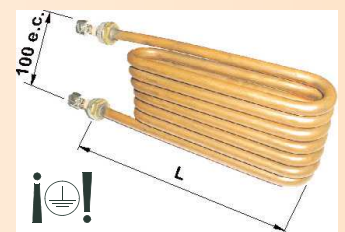

U-SHAPED HEATING ELEMENTS WITH COUPLING CONNECTORS

General characteristics

- Tubular elements of nickel-plate copper or stainless steel AISI 304L or AISI 321 Ø8 mm, insulated with electromelted and lamination-compressed magnesium oxide
- M13 x 1'25 brass connectors, welded to the tube with silver alloy.
- Standard Voltage ~230 V

Code	L in mm	Thread	Watts	W/cm²	Tube material	Electricfor's construct. thermic class	Weight in Kg
U001	180	M13	500	8,3	Stainless Steel	T-600-E	0,14
U001C	180	M13	500	8,3	Nick. cooper.	T-175-E	0,14
U002	260	M13	750	7,5	Stainless Steel	T-600-E	0,17
U002C	260	M13	750	7,5	Nick. cooper.	T-175-E	0,17
U003	350	M13	1000	7	Stainless Steel	T-600-E	0,21
U003C	350	M13	1000	7	Nick. cooper.	T-175-E	0,21
U004	520	M13	1500	6,6	Stainless Steel	T-600-E	0,28
U004C	520	M13	1500	6,6	Nick. cooper.	T-175-E	0,28
U005	680	M13	2000	6,5	Stainless Steel	T-600-E	0,35
U005C	680	M13	2000	6,5	Nick. cooper.	T-175-E	0,35





The GCB heating groups consist of a group of hairpin shaped elements soldered to standardised DIN2527 or ANSI flange of suitable diameter and nominal pressure, with its corresponding connection box.

The GCB heating groups are specifically adapted for heating and temperature maintenance of large volumes or for heating of fluids in circulation, such as water, heavy fuel-oil, thermal oils, air or gas.

Installation may be carried out indistinctly in vats or cisterns, in boilers or pass superheaters.

They represent an optimum electric heating system for such diverse industries as agroalimentary, chemical, textile, etc.

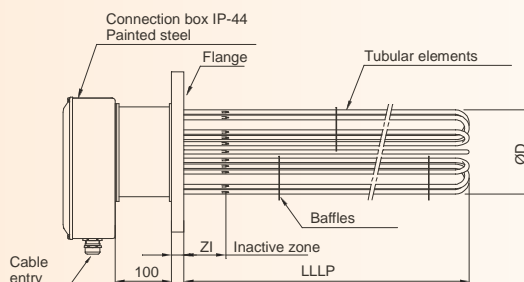

General characteristics

- Power according to your specifications
- Voltage supply 3-400 V Δ
- Density load up to 16 W/cm². Recommended density load according to applications
 - 1 to 3 W/cm² → Air, ovens
 - 1,2 W/cm² → Heavy fuel-oil
 - 2 to 4 W/cm² → Thermic oil, light fuel-oil
 - 6 to 8 W/cm² → Water
- Shape "U" tubular elements
- Tube material in stainless steel AISI 321, AISI 316L or Incoloy®-825
- Standardized tube diameters: Ø10 mm
- Maximum length flat plate: Standardized models until 1750 mm, on demand until 3300 mm
- Inactive zone (ZI) standardized models: 100 mm
- Standard flanges: DIN 2527 in steel
- Connection box IP-44.
- 2 Sheats of Øint6,5 mm for thermostat, limiter, thermocouple or PT100 sensor.
- Optionally, temperature control with thermostat, limiter, thermocouple or PT100 sensor
- Optionally, we can supply the GCB group with the cabinet of electrical set-up with all the components and necessary protections for its connection: Controllers, switches, relays, circuit breakers, etc...

IMPORTANT: When the heating groups GCB settle in a container affected by the Pressure Equipment Directive PED 97/23/EC, they will only be able to be used in equipment with a maximum design pressure according to the following parameters (extracted from the standard EN 1092-1, Table G.2.1-3 - PN10)

Design temperature	Maximum design pressure
Up to 99 °C	8 bar
From 100 °C to 149 °C	7,2 bar
From 150 °C to 199 °C	6,8 bar
From 200 °C to 249 °C	6,3 bar

STANDARDIZED MODELS GCB-V, RANGE FOR STEAM GENERATOR. MAXIMUM WORK TEMPERATURE: 150 °C

DN Flange	ØD in mm	Nº elements. (Tube ly-825® Ø10 mm)								Length flat plate (LLLp in mm)						
		6	9	12	15	18	21	24	27	30	600	800	1000	1250	1500	1750
DN Flange	100	X									6 kW	7,5 kW	9 kW	12 kW	15 kW	20 kW
	150		X								9 kW	11,25 kW	13,5 kW	18 kW	22,5 kW	30 kW
					X						12 kW	15 kW	18 kW	24 kW	30 kW	40 kW
	200					X					15 kW	18,75 kW	22,5 kW	30 kW	37,5 kW	50 kW
						X				18 kW	22,5 kW	27 kW	36 kW	45 kW	60 kW	
250							X			21 kW	26,25 kW	31,5 kW	42 kW	52,5 kW	70 kW	
								X		24 kW	30 kW	36 kW	48 kW	60 kW	80 kW	
									X	27 kW	33,75 kW	40,5 kW	54 kW	67,5 kW	90 kW	
									X	30 kW	37,5 kW	45 kW	60 kW	75 kW	100 kW	

STANDARDIZED MODELS GCB-AT, RANGE FOR THERMIC OIL. MAXIMUM WORK TEMPERATURE: 150 °C

DN Flange	ØD in mm	Nº elements. (Tube AISI 321 Ø10 mm)								Length flat plate (LLLp in mm)						
		6	9	12	15	18	21	24	27	30	600	800	1000	1250	1500	1750
DN Flange	100	X									8 kW	10,5 kW	13,5 kW	18 kW	21 kW	25,5 kW
	150		X								12 kW	15,75 kW	20,25 kW	27 kW	31,5 kW	38,25 kW
					X						16 kW	21 kW	27 kW	36 kW	42 kW	51 kW
	200					X					20 kW	26,25 kW	33,75 kW	45 kW	52,5 kW	63,75 kW
						X				24 kW	31,5 kW	40,5 kW	54 kW	63 kW	76,5 kW	
250							X			28 kW	36,75 kW	47,25 kW	63 kW	73,5 kW	89,25 kW	
								X		32 kW	42 kW	54 kW	72 kW	84 kW	102 kW	
									X	36 kW	47,25 kW	60,75 kW	81 kW	94,5 kW	114,75 kW	
									X	40 kW	52,5 kW	67,5 kW	90 kW	105 kW	127,5 kW	

STANDARDIZED MODELS GCB-A, RANGE FOR WATER. MAXIMUM WORK TEMPERATURE: 150 °C

DN Flange	ØD in mm	Nº elements. (Tube AISI 316L Ø10 mm)								Length flat plate (LLLp in mm)						
		6	9	12	15	18	21	24	27	30	600	800	1000	1250	1500	1750
DN Flange	100	X									15 kW	21 kW	27 kW	33,3 kW	42 kW	50 kW
	150		X								22,5 kW	31,5 kW	40,5 kW	50 kW	63 kW	75 kW
					X						30 kW	42 kW	54 kW	66,7 kW	84 kW	100 kW
	200					X					37,5 kW	52,5 kW	67,5 kW	83,3 kW	105 kW	125 kW
						X				45 kW	63 kW	81 kW	100 kW	126 kW	150 kW	
250							X			52,5 kW	73,5 kW	94,5 kW	116,7 kW	147 kW	175 kW	
								X		60 kW	84 kW	108 kW	133,3 kW	168 kW	200 kW	
									X	67,5 kW	94,5 kW	121,5 kW	150 kW	189 kW	225 kW	
									X	75 kW	105 kW	135 kW	166,7 kW	210 kW	250 kW	



The GCB heaters (flange heaters) are heating units designed to work under pressure. They are constructed through the welding of various reinforced heating elements to a standard blind flange.

The design of a GCB can vary significantly. Working pressure, the desired temperature or the fluid to be heated are just some of the factors that can affect which system to design. This is why each case is assessed by our technical department in order to provide a product that meets the specific requirements of each of our customers.

The following guide will help you find out more about the design of these devices, from their main materials to the welding processes appropriate for each situation. The following pages show the different manufacturing standards for this equipment and explain the pros and cons of each design according to the above requirements.

DIN / ASME Flanges.		Material	Code
DIN	Steel	S235JR	D235
		P250GH	D250
	Stainless Steel	AISI-304L	D304
		AISI-316L	D316
ASME	Steel	A-105	A105
	Stainless Steel	AISI-304L	A304
		AISI-316L	A316

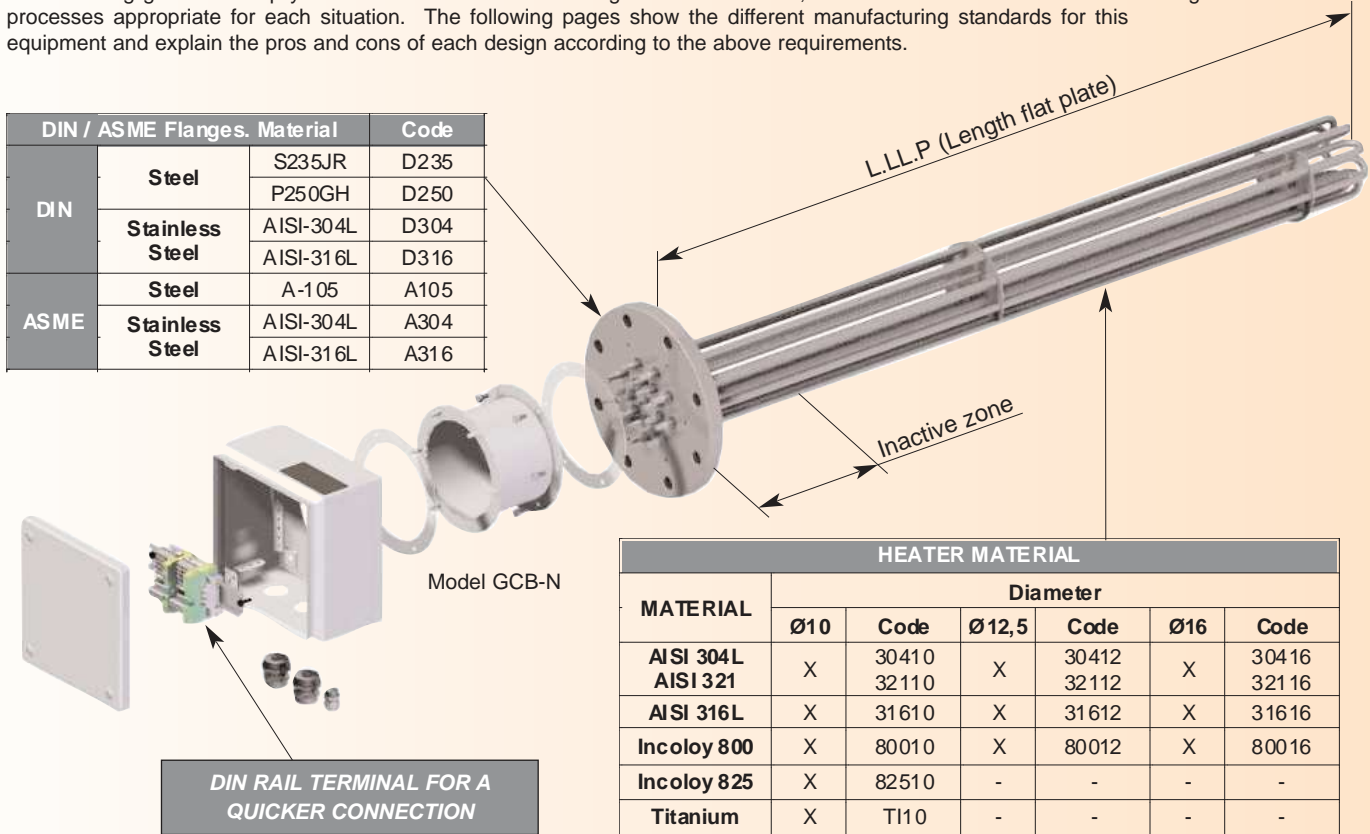

Electrical protection against outdoor conditions is through junction boxes or small control panels that prevent external elements getting inside (dust, water, etc.). This protection is calculated according to each application's special requirements.

Separators / Deflectors

To prevent contact between the heating elements our units include separators (see figure 1). These consist of a sheet whose diameter is always less than the nominal diameter of the flanges and that stiffens the heating elements thus preventing buckling or contact with contaminants during the element's lifecycle.

When the equipment is for heating a fluid in constant circulation, in most cases the flow needs to be directed to aid contact with the heater. Deflectors are included in these units for this (see figure 2).

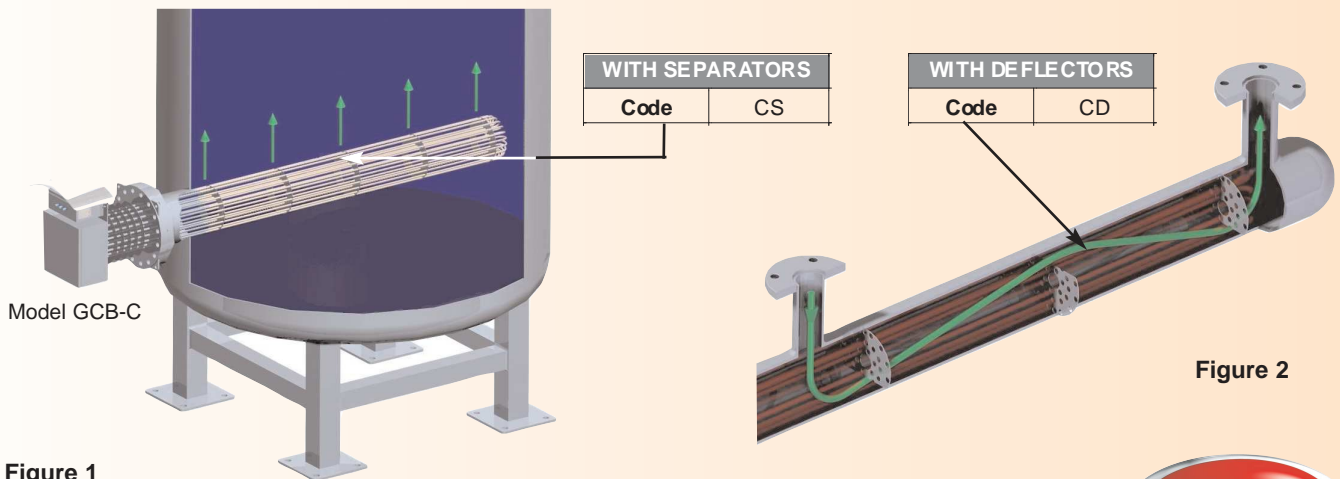

Figure 1

Figure 2

The GCB N heating units are the most frequently used and represent our standard manufacturing for this kind of flanged elements. They are constructed by coupling the junction box through a metal duct that is screwed to the flange and the box.

The heating elements remain near the flange and they are connected by placing strips in the junction boxes. This means the heating elements remain inter-connected so that once the customer receives them it is just a matter of the power reaching the strips.

Meanwhile, the seals between the flange and the duct, and between the duct and the box provide protection against dust and humidity of up to IP-66, as long as the box allows it, which makes them apt for working outdoors.

This kind of construction means the product is simple to assemble and easy to handle for practically anything. However, it is important to remember that the maximum heating temperature this composition permits is 150°C.

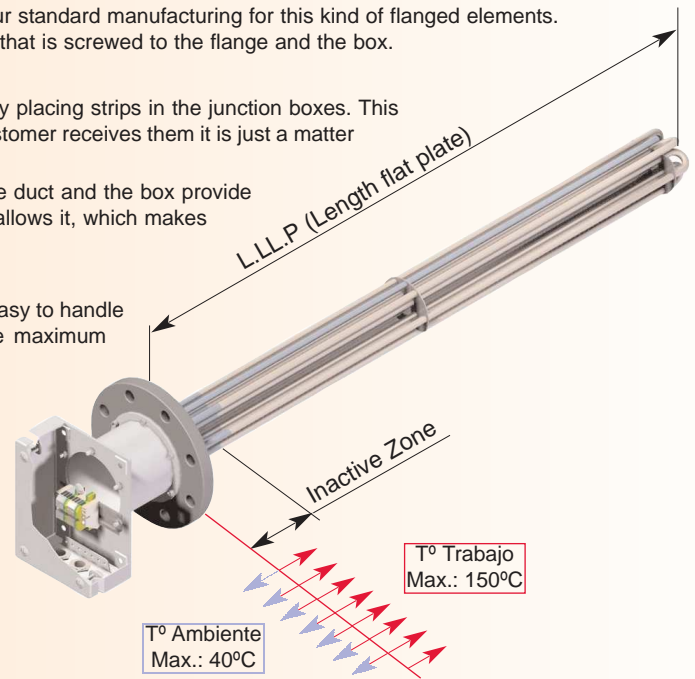

CONSTRUCTION OF FLANGES WITH DUCT

CONNECTION BOX		
IP	Material	Code
54	Painted steel	A54
54	S. Steel	I54
66	Painted steel	A66

(*) It is recommended that the exterior zone should always remain under a covered area. If this is not possible, the unit should be protected from direct water and wind, even if only with IP-66 protection.

FLANGE-HEATER WELDING	
Type	Code
Brazing silver alloy	P1
Welding TIG without contibution	T1

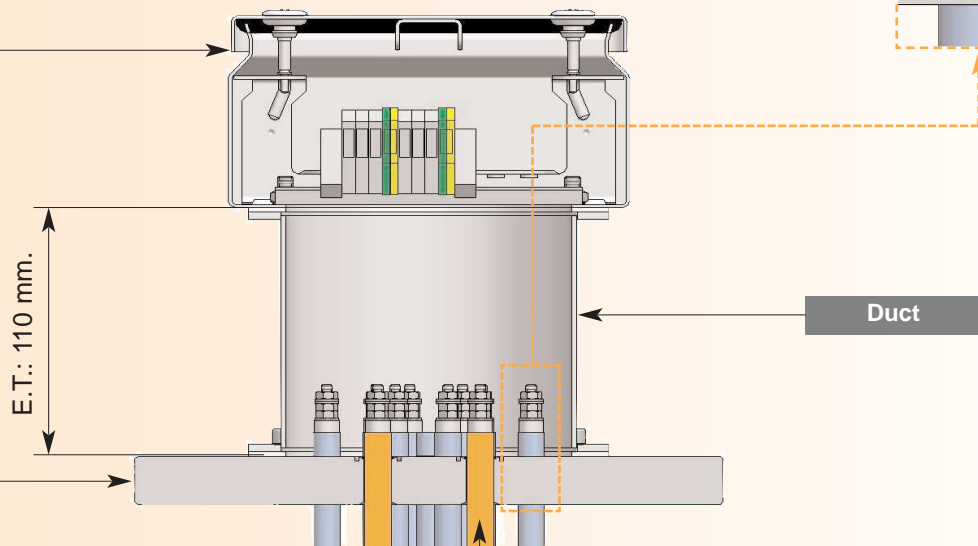
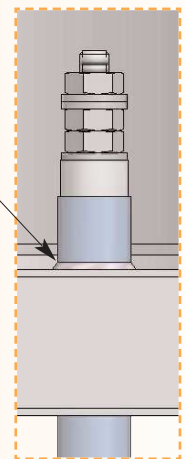

MAIN FLANGE	
Standards	Code
DIN	D
ASME	A

Heating element



The GCB-C heating units are mostly used for facilities where the working temperature exceeds 150°C. They are built to separate the terminals area and electrical connection from the heating element activity area, so that the former are not affected by the high temperature. Also, when the temperature is really high, heat sinks can be installed in the Thermal Zone to encourage temperature dissipation and therefore prevent excessive heating of important areas.

This kind of construction is always the most costly due to its complexity. This is why it is recommended for use only in cases when the working temperature does not permit use of a standard manufacturing model (GCB-N).

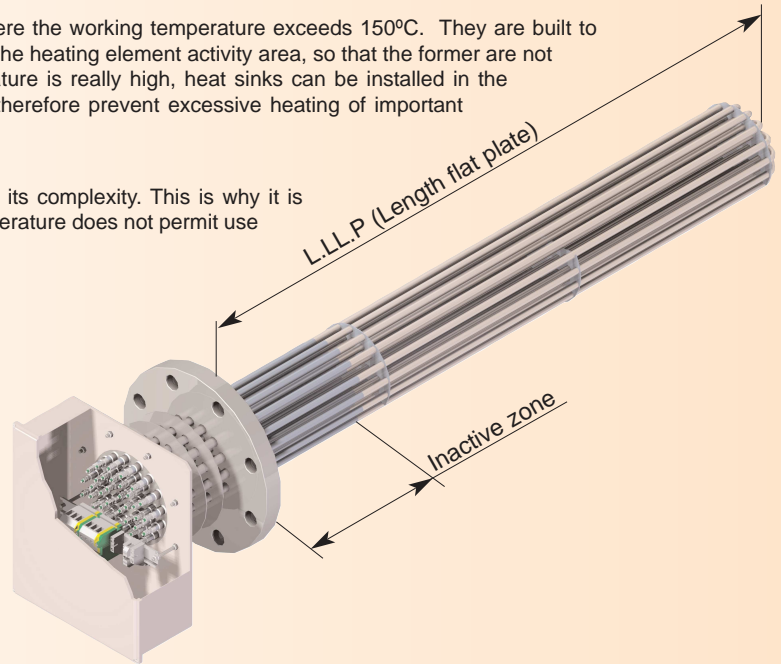

CONSTRUCTION OF FLANGES WITH THERMAL ZONE (TZ) AND BUSHING

CONNECTION BOX		
IP	Material	Code
54	Painted steel	A54
54	S. Steel	I54
66	Painted steel	A66

(*) It is recommended that the exterior zone should always remain under a covered area. If this is not possible, the unit should be protected from direct water and wind, even if only with IP-66 protection.

SHELL – HEATER WELDING	
Type	Code
Brazing silver alloy	P3
TIG welding without contribution	T3

SHELL – PLATEN WELDING	
Type	Code
Brazing silver alloy	P2
TIG welding without contribution	T2

Note: the combination of T3 and T2 is not recommended in the same element.

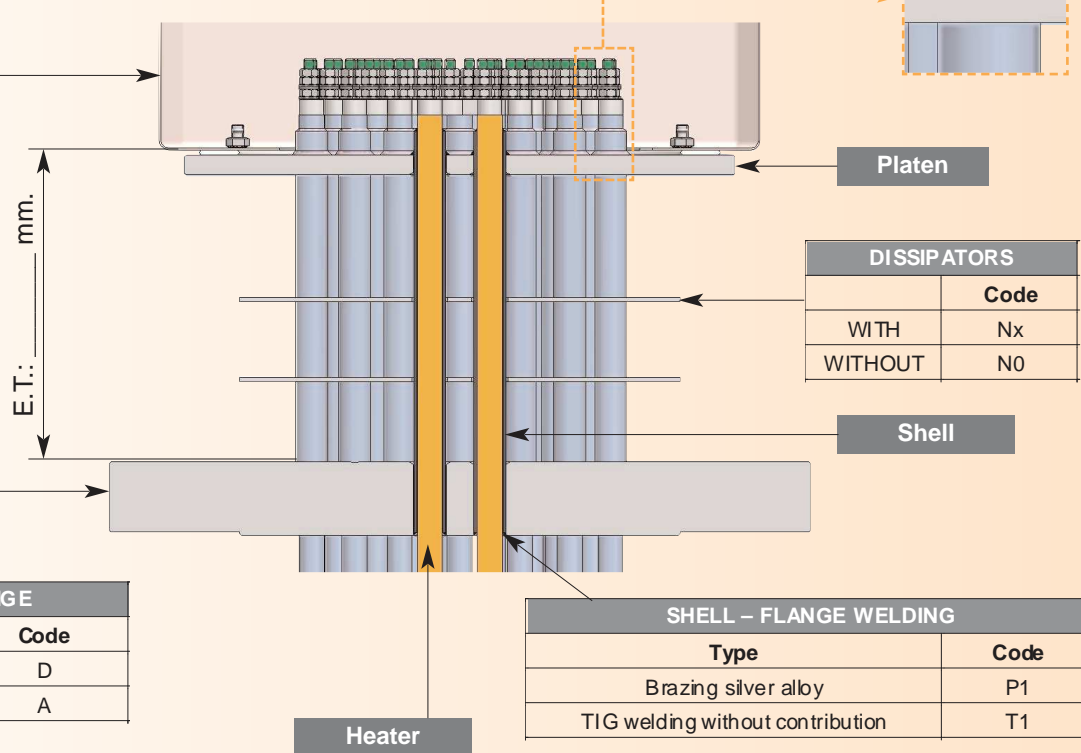
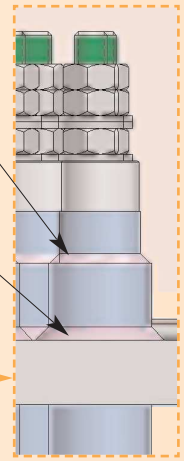

MAIN FLANGE	
Standards	Code
DIN	D
ASME	A

SHELL – FLANGE WELDING	
Type	Code
Brazing silver alloy	P1
TIG welding without contribution	T1

DISSIPATORS	
	Code
WITH	Nx
WITHOUT	N0

The heating units GCB-ET are made up of a group of heating elements that are welded to the standard flange and at the same time to a platen. This platen is what keeps the junction box fastened and it is adapted to it so that the IP conditions required in each case can be maintained.

This type of construction is used when the temperature exceeds 150°C and therefore space has to be left between the connection flange and the heating element terminals to prevent damage to the sealing.

They are a good option for equipment that does not have an excessively large flange and the number of rods to be welded is not that high. In this case, or depending also on the application, the GCB-C can also be used, as explained on the following page.

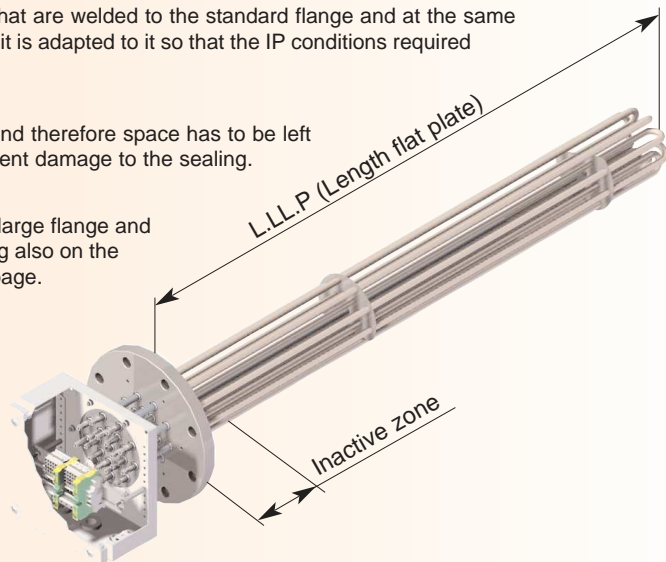

CONSTRUCTION OF FLANGES WITH THERMAL ZONE (ZT) WITHOUT BUSHING

CONNECTION BOX		
IP	Material	Code
54	Painted steel	A54
54	S. Steel	I54
66	Painted steel	A66

(*) It is recommended that the exterior zone should always remain under a covered area. If this is not possible, the unit should be protected from direct water and wind, even if only with IP-66 protection.

SHELL – PLATEN WELDING	
Type	Code
Brazing silver alloy	P2
TIG welding without contribution	T2

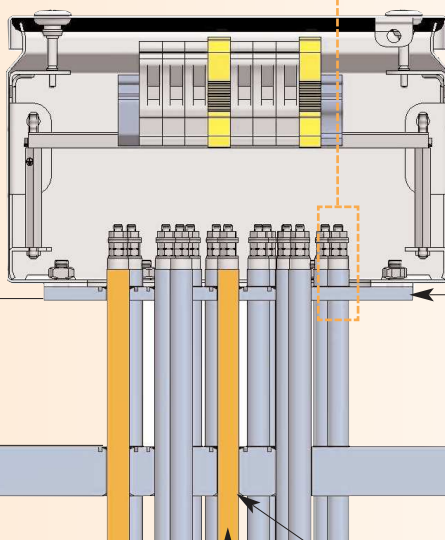
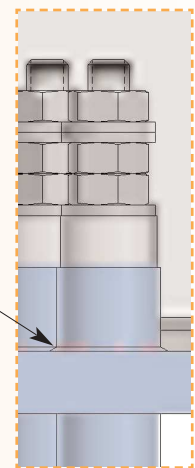

MAIN FLANGE	
Standards	Code
DIN	D
ASME	A

FLANGE – HEATER WELDING	
Type	Code
Brazing silver alloy	P1



The heating units GCB-R are reinforced elements with inter-changeable heating elements. They are mainly used for applications when the heating elements are exposed to strong conditions and continuous replacement needs to be anticipated.

Manufacturing this kind of element consists of welding sheaths to the coupling flange. These sheaths hold the heating elements and enable them to be replaced when they are no longer operational. Connecting and disconnecting the heating elements is very simple as this kind of device includes power distributors. These distributors enable the electricity to be directed from the customer's connection to all the heating elements.

This design with interchangeable heating elements can be manufactured the same as the GCB-C manufacturing process but without the welding of the heating element.

Optionally other kinds of interchangeable heating elements can be manufactured, (glow plugs, one-pipe, etc.)

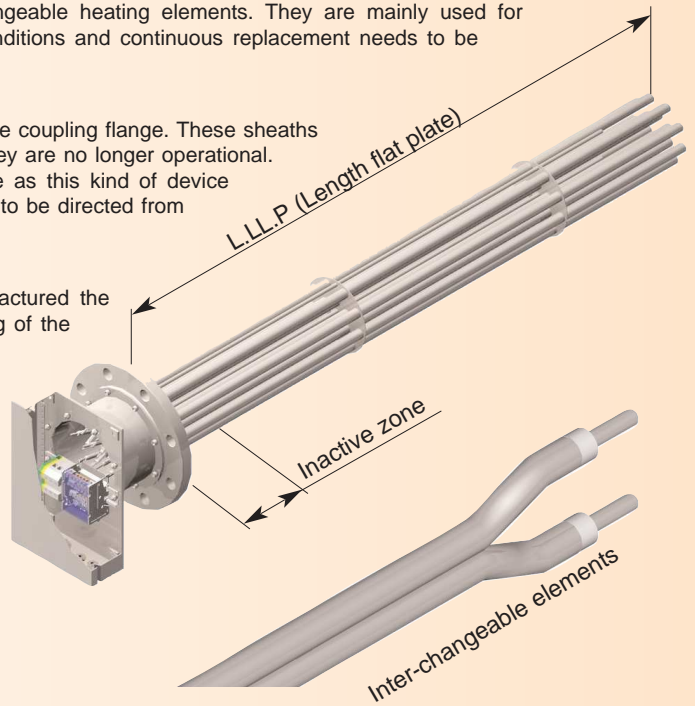

CONSTRUCTION OF FLANGES WITH INTERCHANGEABLE HEATING ELEMENTS

CONNECTION BOX		
IP	Material	Code
54	Painted steel	A54
54	S. Steel	I54
66	Painted steel	A66

(*) It is recommended that the exterior zone should always remain under a covered area. If this is not possible, the unit should be protected from direct water and wind, even if only with IP-66 protection.

FLANGE – SHEATH WELDING	
Type	Code
Brazing silver alloy	P1
TIG welding without contribution	T1

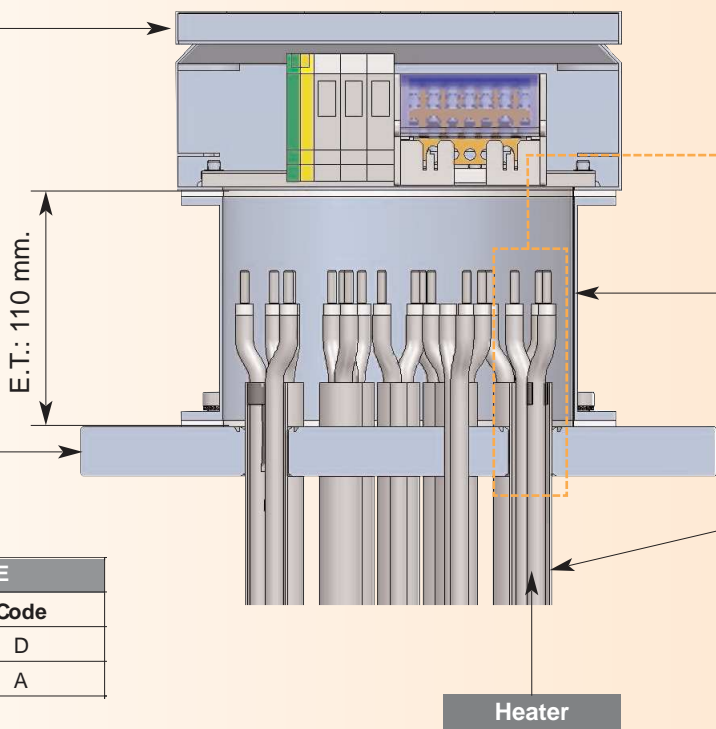
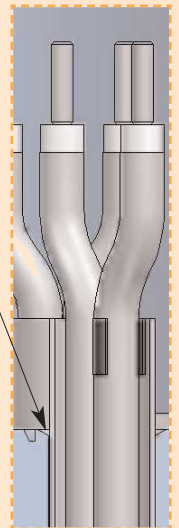

MAIN FLANGE	
Standards	Code
DIN	D
ASME	A

SHEATHS	
ØExt. sheath	Code
Ø19	V19
Ø25	V25

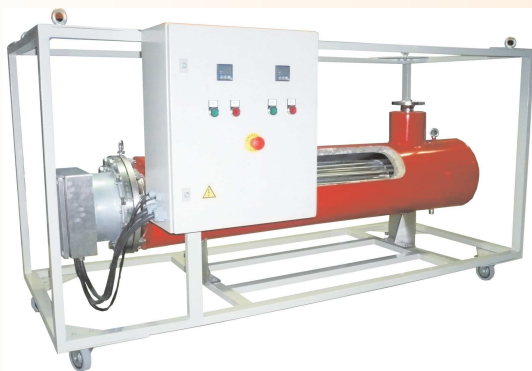

GCP pass superheaters consist of a GCB heating group assembled on a steel or stainless steel tubular body, of suitable flange, bed and entry, exit and purge tubulatures, threaded or flanged. The fluid to be heater circulates inside the same, guided by the deflectors at intervals in the heating group.

The GCP pass superheaters are manufactured to measure, adapting the design for each specific case. They can be manufactured as heat-resistant or non-heat-resistant depending on the working temperature of the same, in horizontal or vertical position, etc.

General characteristics

- Shape "U" tubular elements
- Tube material in stainless steel AISI 321, AISI 316L, Incoloy®-800, Incoloy®-825 or nicked copper
- Standardized tube diameters: Ø8, Ø10, 12'5, Ø16 mm
- Power according to your specifications

- Three-phase voltage up to 750 V
- Maximum length flat plate: 3300 mm
- Standard flanges: DIN - ANSI in stainless steel or steel
- Connection box IP-44. Tubular body in stainless steel or galvanized steel
- Optionally, tubular body with heat-resistant insulation
- Temperature control with thermostat, limiter, thermocouple or PT100 sensor

- Density load up to 16 W/cm². Recommended density load according to applications
 - 1 to 3 W/cm² → Air, ovens
 - 1,2 W/cm² → Heavy fuel-oil
 - 2 to 4 W/cm² → Thermic oil, lighth fuel-oil
 - 6 to 8 W/cm² → Water

If you wish to receive an offer for the GCP heating groups appropriate to your needs, please complete the attached tables indicating the data requested and send it by fax. You will receive a quote from us as soon as possible.

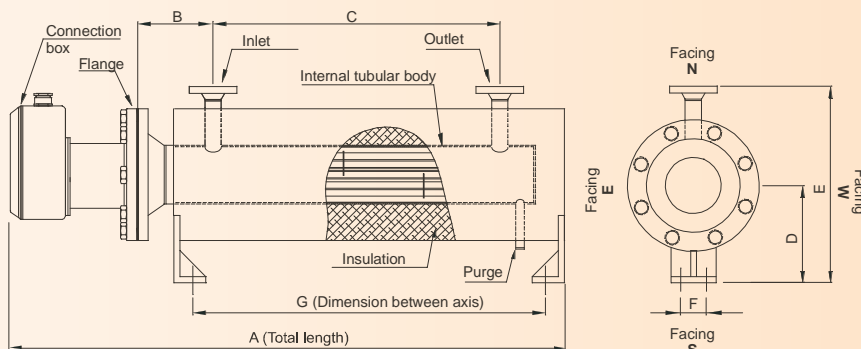

Process requirements	
Medium to heat: (Indicate material)	Liquid <input type="radio"/>
	Gas <input type="radio"/>
Static material	Q <input type="checkbox"/> dm ³ /h
In line material characteristics	Density <input type="checkbox"/> Kg/dm ³
	Viscosity <input type="checkbox"/> cP
	Specific heat <input type="checkbox"/> KJ/kg.K
Work temperature	<input type="checkbox"/> °C
Inlet temperature	<input type="checkbox"/> °C
Outlet temperature	<input type="checkbox"/> °C
Design pressure	P <input type="checkbox"/> kg/cm ²

Tubular element characteristics			
Tube material	SS AISI 321 <input type="radio"/>	Incoloy®-825 <input type="radio"/>	
	SS AISI 316L <input type="radio"/>	Steel <input type="radio"/>	
Tube diameter	Incoloy®-800 <input type="radio"/>	Copper <input type="radio"/>	
	Ø8 mm <input type="radio"/>	Ø16 mm <input type="radio"/>	
	Ø10 mm <input type="radio"/>		

Electrical characteristics	
Total Watts	<input type="checkbox"/> kW
Power supply	V (Mono-phase) <input type="checkbox"/>
	V (Three-phase) <input type="checkbox"/>
Connection	Mono-phase <input type="checkbox"/>
	Three-phase Δ <input type="checkbox"/>
	Three-phase λ <input type="checkbox"/>
N ^o steps	<input type="checkbox"/>
Density load	<input type="checkbox"/> W/cm ²

In line heater			
Material internal tubular body	Steel <input type="radio"/>	SS AISI 321 <input type="radio"/>	
		SS AISI 316 <input type="radio"/>	
Position	Horizontal <input type="radio"/>		
	Vertical <input type="radio"/>	Box position <input type="checkbox"/>	Top <input type="radio"/> Lower <input type="radio"/>
Heat-resistant insulation	Yes <input type="radio"/>		
	No <input type="radio"/>		

Temperature control		
Safety	Fluid temperature <input type="checkbox"/>	°C
	Tube temperature <input type="checkbox"/>	°C
Control	Fluid temperature <input type="checkbox"/>	°C
	Thermostat (ON/OFF) <input type="radio"/>	Range <input type="checkbox"/> °C
Type	Thermocouple sensor. Type:	
	J <input type="radio"/>	PT100 <input type="radio"/>
	K <input type="radio"/>	
Position (Flat plate)	<input type="checkbox"/>	mm

Inlet / Outlet - Flanges					
Flange	DIN		ANSI		Facing NSEW
	PN	DN	PN	DN	
Inlet					
Outlet					
Flange material	Steel <input type="radio"/>	SS AISI 321 <input type="radio"/>			
		SS AISI 316 <input type="radio"/>			
Purge	Yes <input type="radio"/>				
	No <input type="radio"/>				
Dimensions in mm	A		E		
	B		F		
	C		G		
	D				



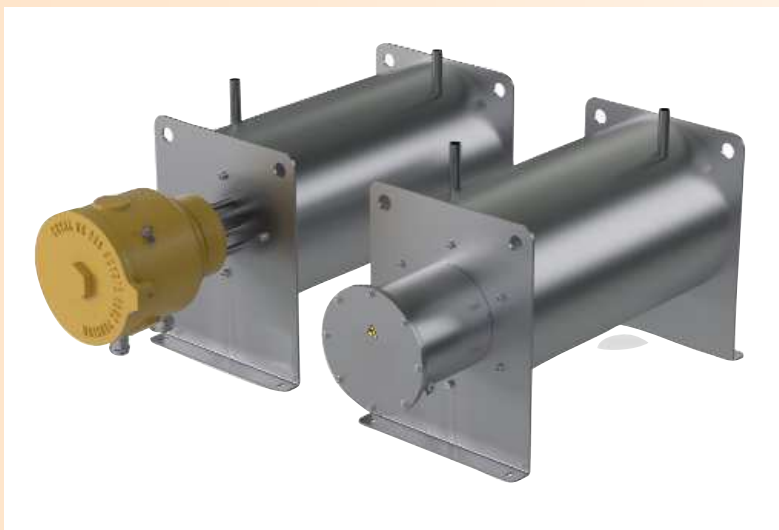

The developed Cast-In Circulation Heater Technology offers a safe and precise integrated solution for your process heating requirements.

Operating principle

This system is the ideal solution for heating gaseous, liquid or two-phase fluid at a specific flow rate.

Cast-in heaters consists of a cylindrical cast aluminium block which is heated. The fluid to be heated circulates through an helical coil which is embedded in the cast aluminium block. The heat is precisely and efficiently transferred to the gas or liquid.

To minimise heat losses, the aluminium block is thermally insulated and protected by a casing.

As the system is highly flexible, the heater can be connected in series or in parallel, according to power requirements..

Applications

- Natural gas, butane, propane, N2, CO2, H2
- Oxygen: Special designs
- Hydrocarbons, solvents and paints
- Sensitive fluids and gas applications
- UHP applications
- Agri-food: pasteurisation / sterilisation

Advantages

- Indirect heating
- Less expensive than a conventional heater
- Compact design, smaller footprint
- Precise, even heating
- Easy cleaning
- Operates at very high pressure
- Standard wide range sized according to flow rate and power output

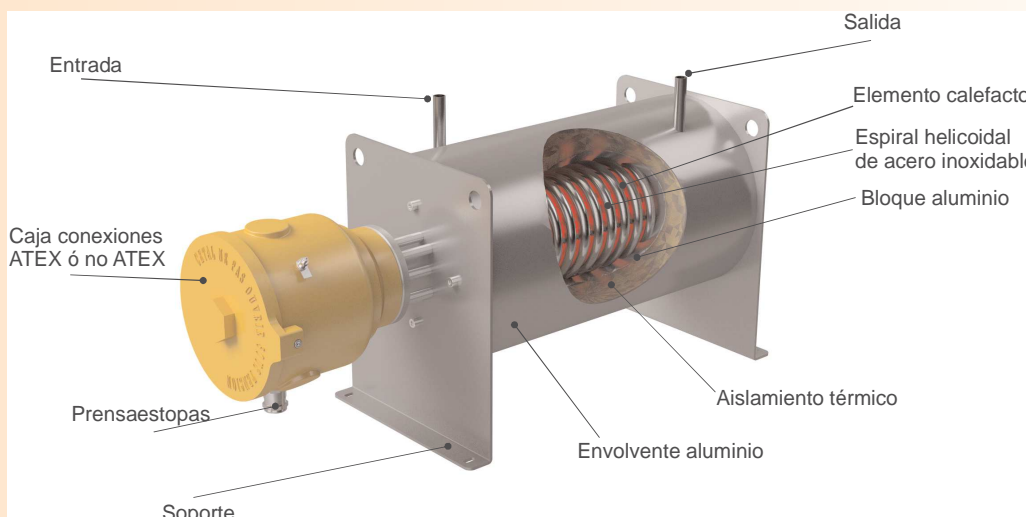

Technical advantages of indirect heating

- No direct contact between the fluid to be heated and the heating elements
- Optimized heat exchange
- Homogeneous heating, no hot spots during system start-up and temperature rise phase
- Easy cleaning

Regulation and control

A temperature probe is fitted as standard to monitor and control the skin temperature of the heating elements.

Other temperature probes are available as optional extras (for the aluminium block or at the heater inlet and outlet).

A control cabinet is used to control the heater.

ATEX and non-ATEX versions available

The entire system is available in an explosion-proof version for the ATEX T1 (450°C) to T6 (85°C) environment or for other "safe" environment applications.

A compact alternative

Cast-in circulation heaters are excellent alternatives to conventional heaters consisting of an immersion heater mounted in a body.

They save space, have lower costs and are very competitive for high pressure applications.

System maintenance is also considerably reduced.

ELECTRICFOR flexibility

Electricfor heaters are available for specific flow rates and process power requirements.

The range starts at 1.5 kW to 32 kW as standard and is available with either a 230 V single-phase, 400 V three-phase to 690 V three-phase power supply.



Standardized Models

Delivery time: 8 weeks to be counted from the approval of the technical documentation

Defining design based on the application

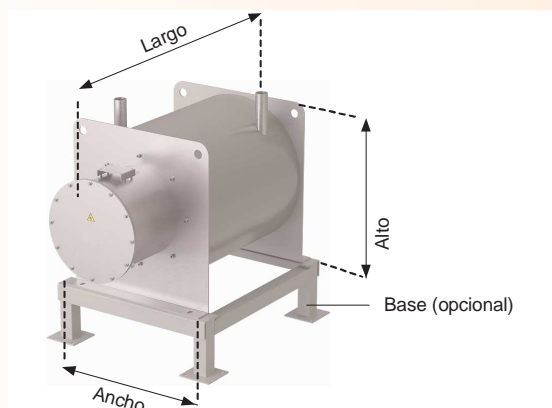

Type	Power KW	Max flow-rate at 8 bar (Nm³/h)	Max flow-rate at 80 bar (Nm³/h)	Max liquid flow-rate m³/h	Distance between inlet & outlet in mm	Ext. Ø of helical coil in mm	Tube thick in mm	Dimensions in mm			Weight in Kg
								Width	Length	Height	
Cast-in 01-xx KW	1.5 / 3	10	100	0.2	90	6.35	1.24	240	470	190	30
Cast-in 02-xx KW	1.5 / 3	25	250	0.5		8	1				30
Cast-in 03-xx KW	1.5 / 3 / 6	40	400	1		10	1				30
Cast-in 04-xx KW	1.5 / 3 / 6	55	560	1.5	140	13.7	2.24	310	500	220	45
Cast-in 05-xx KW	3 / 6 / 9 / 12	120	1300	3		17.2	1.6				45
Cast-in 06-xx KW	3 / 6 / 9 / 12 / 24	180	1900	4		21.3	2.11				90
Cast-in 07-xx KW	6 / 9 / 12 / 24	320	3300	7	250	26.7	2.11	430	520	275	95
Cast-in 08-xx KW	6 / 9 / 12 / 24	540	5500	11		33.4	2.77				110
Cast-in 09-xx KW	6 / 9 / 12 / 24 / 32	850	8600	19		42.2	2.77				240
Cast-in 10-xx KW	9 / 12 / 24 / 32	1150	12000	26	390	48.3	2.77	590	550	345	250

Technical data

Attachment and connection

- Standard smooth welding end

Options:

- 1/2" to 2" ASME/ANSI B16.5 stainless steel RF flange, 150 lbs to 600 lbs
- PN 40 or PN 100, DN15 to DN50, RF flange. Other seal bearing on request for ASME or DIN flange
- Stainless steel female 1/8" to 1 1/2" diameter standard NPT or gas or 3000lbs union fitting
- Back flange, nuts and bolts and PTFE or spiral wound graphite seal

Operating conditions

- Operating temperature: from -196 °C to +350 °C (-273 °C on request)
- Operating flow rate: from 10 Nm³/h to 12000 Nm³/h max. depending on operating pressure and gas
- Up to 100 bar operating pressure as standard
- Very high pressure up to 420 bar on request

Electrical

- Power: 1.5 kW to 32 kW per unit
- 230 V AC single-phase or three-phase
- 400 V AC three-phase and up to 690 V three-phase optional

Coil

- Fluid circulation and heating in a 316L stainless steel coil
- Pickled, passivated seamless tube for better mechanical strength
- 6.35 mm to 48.3 mm diameter

Options:

- Incoloy or inconel coil
- Coil electro polishing
- Oxygen degreasing

Temperature control

- Three-wire PT100 probe for monitoring the heating element temperature

Options:

- Safety thermocouple or safety limiter thermostat or thermal fuse
- Temperature regulation of the aluminium cast-in unit by PT100 probe, thermocouple or thermostat
- Process regulation with temperature monitoring by PT100 probe at the

outlet or thermocouple (in a separate housing)

- Temperature measurement at the heater inlet by PT100 probe, thermocouple or thermostat (in a separate housing)
- 4-20 mA transmitter with or without HART protocol for PT100 probes or thermocouples (ATEX version if an Ex e housing is used)

Non-ATEX connection box

- Stainless steel IP66/67 connection box
- Two nickel-plated brass cable glands for power and control

ATEX connection box

- Aluminium explosion-proof box with protective paint, Ex d IIC or stainless steel Ex e II C increased safety box

- Two nickel-plated brass cable glands for power and control

Options:

- Anti-condensation heating tape
- Cable gland for additional temperature probe

Insulation and mounting

- Foamglas® / rock wool / ceramic insulation depending on operating temperatures and the fluid being heated

- Protective aluminium jacket

- Horizontal foot mounting

Self-draining

- Available option : Vertical mounting configuration

- Gas bleed and complete drain down

Certifications (if required)

- nforms to Pressure Equipment Directive 2014/68/EU

ATEX (option)

Exd IIC T1 to T6

Ex IIC 2GD Ex tD A21 IP67

- Ambient temperature: -50 °C ≤ Ta ≤ + 60 °C

- According to CE LCIE 04 ATEX 6094X examination certification

A correct choice of setting and switch system material increases the results of the thermo-electrical elements and guarantees that the system works properly within the established working limits.

All Electricfor control and switch boards are designed to respond to European safety specifications.

Choice of whether the control board is a standard model or a made to measure model following specific specifications will depend largely on the following criteria:

- Type of control method
- Required setting accuracy

If its application refers to a high thermal inertia process (for example, heating of large water or oil tanks), an ACO- type control board with ALL/NOTHING settings by contactors may be the best solution.

If on the other hand your process consists in instantaneous heating of circulating fluid (for example, tankless heaters) or you require rapid reactions in the setting system with great accuracy of temperature control, then the most suitable control board for you will be an ACT-type with a power setting by thyristors.

Contact our technical service for them to help you choose the most suitable equipment for each application.

Apart from setting and switch boards, you will also find a wide range of both mechanical and electronic action thermostats, of ALL/NOTHING, PD and PID type on pages 136 to 143 of this catalogue.

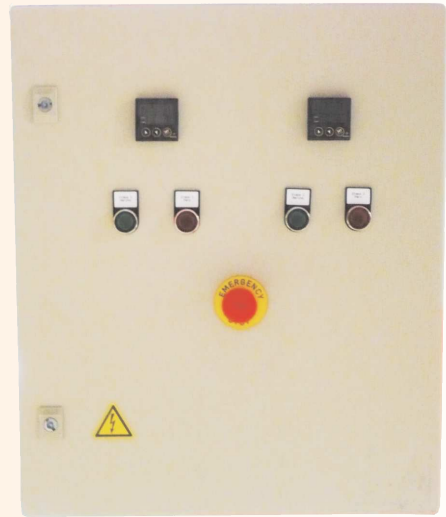

ACO model control and switch boards.

Power control by contactor (ALL-NOTHING)

- Board of an appropriate size for each range of power with IP-65 damp protection rating
- Control of one ALL/NOTHING power stage controlled by a remote thermostat
- Connection input for a safety thermostat
- Front running switch with door blocking and integrated fuses

Code	Voltage	Maximun nominal power, in KW	Dimensions in mm		
			High	Wide	Deph
ACO12	3N~400	12 kW	400	400	200
ACO27	3N~400	27 kW	400	400	200
ACO50	3N~400	50 kW	500	500	300
ACO61	3N~400	61 kW	500	500	300



ACT model control and switch boards

Power control by thyristor

- Painted steel board of an appropriate size for each range of power with IP-41 damp protection rating.
- 1 sectioner door blocking + general protection.
- 1 safety contactor (overheating of the process/internal overheating/external contact).
- 1 break thyristor on 3 phases (in the 3N~400 V versions) with RC varistors and circuits.
- Feed and outlets on terminal block.
- 1 PID adjustable temperature controller.

Code	Voltage	Maximun nominal power, in KW	Dimensions in mm		
			High	Wide	Deph
ACT8	~230	8 kW	300	300	250
ACT12	3N~400	12 kW	300	300	250
ACT22	3N~400	22 kW	400	400	250
ACT27	3N~400	27 kW	600	500	311
ACT51	3N~400	51 kW	600	500	311
ACT60	3N~400	60 kW	600	500	311
ACT86	3N~400	86 kW	600	500	311



General characteristics

- Electric heating element Class I.
 - Hermetic head (Degree protection against moisture IP67) in steel, except C405 model in stainless steel AISI 316.
 - The upper part of the hermetic head incorporates a female 1/2" BSP thread to connect a tube.
 - Heating element in stainless steel tube AISI 321, except for C405 models in AISI 316L
 - Model C405 with two sheaths of Øint 8,5 mm for temperature sensors or bulb thermostats.
 - Watertight gasket.
 - For installations of acid/basic liquids or especially dense liquid, they can be manufactured in 316L stainless steel tube, Incoloy 800, Incoloy 825, and/or with lower charge densities.
- (*) IP67 protection is ensured in the final installation with the appropriate nipples and joints on the 1/2" BSP female thread.

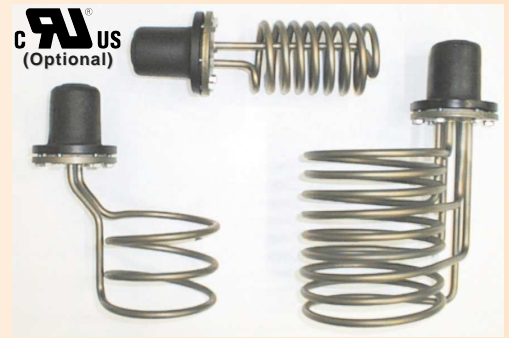

They allow, by means of a 1/2" BSP tube properly connected to the CUP heating element, conserving the degree protection against moisture, to prolong and to protect the connection cables, creating the cold zone and exit to the outside according to your necessities.

The C405 model is provided with two sheaths. The sheaths can be used for implementing control and safety elements, such as rod thermostats TER-xxxx-NEF (see pag 6 and 120) regulatable from 10 - 80 °C, or automatic or manual reset temperature limiters. Model C405 also allows safety elements within its two sheaths, such as fuses for external temperature, range of 15 A of 60 °C and 93 °C in temperature of non rearmable safety cut out and automatic reset thermostats models 9700 (13 A) 90 °C and 75 °C (see pag 123).

All the other models allow the placing of the previously mentioned security elements inside the CUP, with the exception of the rod thermostats

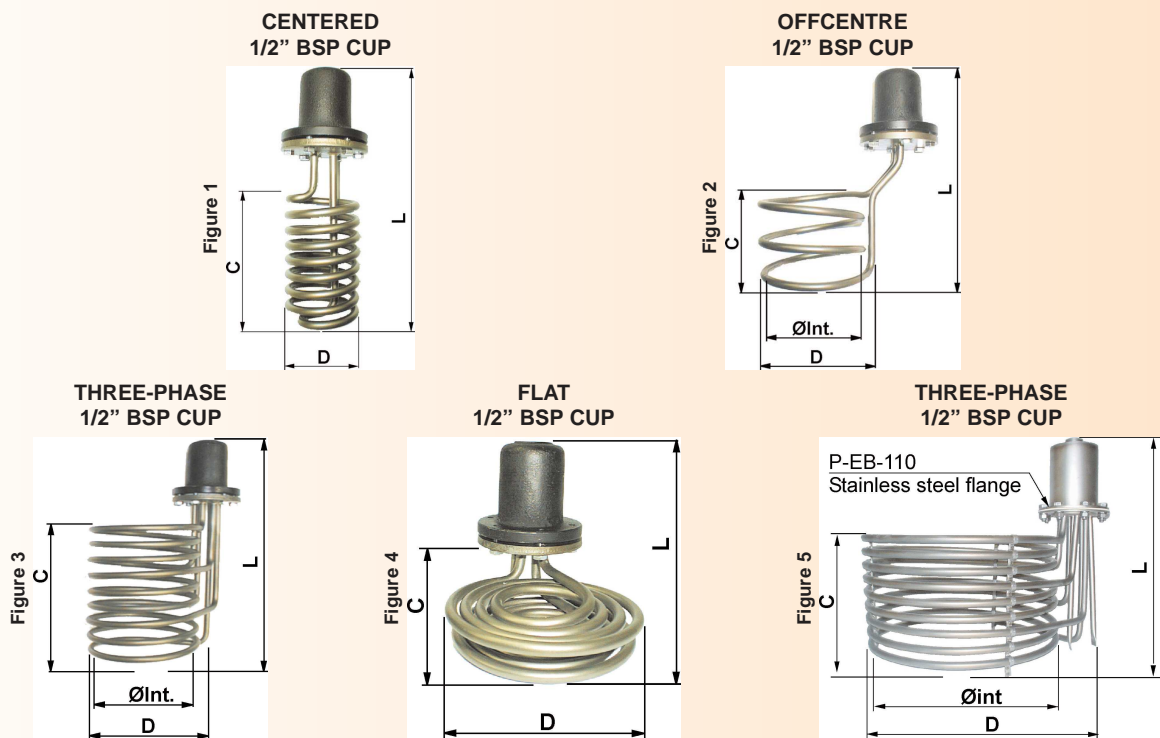

Figure	Code	Dimensions in mm				Volts	Watts	W/cm ²	Tube material	Plate and connection box material	Electricfor's constructive thermic class	Weight in Kg
		C Heatig zone	D	ØInt	L							
1	C010	135	73	-	240	~230	1500	3,4	AISI 321 Ø8	Steel	T-300-E	1,4
	C011	165	73	-	270	~230	2000	4,0	AISI 321 Ø8	Steel	T-300-E	1,4
	C012	225	73	-	330	~230	3000	3,8	AISI 321 Ø8	Steel	T-300-E	1,7
2	C001	100	120	95	210	~230	1000	3,9	AISI 321 Ø8	Steel	T-300-E	1,2
	C002	100	160	130	210	~230	2000	3,6	AISI 321 Ø8	Steel	T-300-E	1,5
	C003	150	210	184	260	~230	3000	4,0	AISI 321 Ø8	Steel	T-300-E	1,6
	C004	150	210	180	260	~230	4500	3,4	AISI 321 Ø10	Steel	T-300-E	2,4
3	C302	170	170	118	270	3~230 Δ 3~400	3000	3,2	AISI 321 Ø8	Steel	T-300-E	1,8
	C303	230	170	118	330	3~230 Δ 3~400	4500	3,8	AISI 321 Ø8	Steel	T-300-E	2,2
	C304	160	245	190	260	3~230 Δ 3~400	6000	3,3	AISI 321 Ø8	Steel	T-300-E	2,6
4	C013	35	130	-	135	~230	1000	3,5	AISI 321 Ø8	Steel	T-300-E	1,2
	C014	50	130	-	135	~230	2 x 1000	3,6	AISI 321 Ø8	Steel	T-300-E	1,5
5	C405	173	343	280	344	3~230 Δ 3~400	9000	3,1	AISI 316L Ø10	Stainless Steel	T-301-E	4,1



FIXED IMMERSION HEATING ELEMENT WITH IP-44 CONNECTION BOX, CONTROL THERMOSTAT AND TEMPERATURE LIMITER

General characteristics

- Degree protection against moisture IP-44.
- Stainless steel AISI 321 or 304L tube.
- Connection box in painted steel.
- Zinc steel crimped connectors.
- Connection cable type Schuko 16 A.
- Control thermostat.
- Manual reset temperature limiter.
- Luminous On / Off switch
- Standard voltage ~230 V

NOTE: To ensure good system operation and prolonged life of heating elements we advise you to install protection elements such as fluid level controls (See pages 149, 150 and 151).

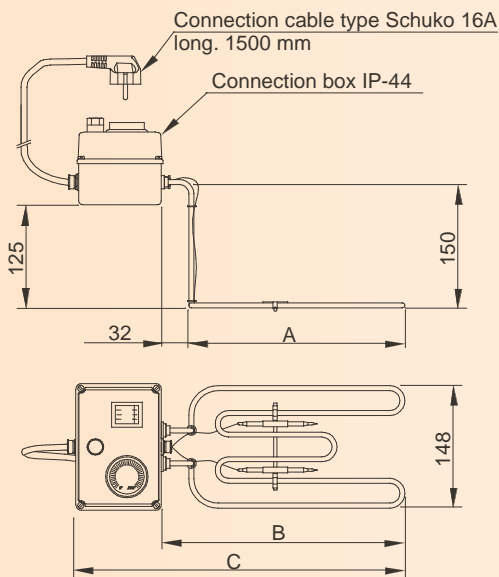

SBR RANGE TO HEAT WATER AND OTHERS APPLICATIONS OF MAXIMUM TEMPERATURE 90 °C.

Specific characteristics

- Bulb control thermostat. Scale 0 - 90 °C. Bulb and capillary in copper
- Manual reset safety limiter. Fixed at 100 °C. Bulb and capillary in copper

Code	Watts	W/cm ²	Tube material	Dimensions in mm			Electricfor's constructive thermic class	Weight in Kg
				A	B	C		
SSBRH1,4	1400	4,7	AISI 321 ó 304L Ø8	196	228	328	T-600-S	1,3

SBR RANGE TO HEAT OIL AND OTHERS APPLICATIONS OF MAXIMUM TEMPERATURE 200 °C.

Specific characteristics

- Bulb control thermostat. Scale 0 - 200 °C. Bulb and capillary in stainless steel.
- Manual reset safety limiter. Fixed at 230 °C. Bulb and capillary in stainless steel.

Code	Watts	W/cm ²	Tube material	Dimensions in mm			Electricfor's constructive thermic class	Weight in Kg
				A	B	C		
SSBRA1,4	1400	4,7	AISI321 ó 304L Ø8	196	228	328	T-600-S	1,3

SPARE HEATING ELEMENTS FOR SBRH and SBRA RANGES

Code	Watts	W/cm ²	Material tube	Electricfor's constructive thermic class	Weight in Kg
RESSBR1,4	1400	4,7	AISI 321 ó 304L Ø8	T-600-S	0,34



IP-44 CONNECTION BOX WITH CONTROL AND SAFETY THERMOSTAT AND ON / OFF LIGHTING SWITCH

General characteristics

Connection box for heating elements. All models including:

- Steel painted box. IP44.
- Control thermostat with automatic reset, chromed face plate and button.
- Manual reset temperature limiter.
- Luminous On / Off switch.
- Cable 3x1,5 mm² with Schuko 16 A plug type.
- PG11 for cable.

- PG9 for control thermostat and limiter bulbs.
- Gaskets for packing glands.
- It can accept other heating element types with connectors, always with maximum current 16A.
- External dimensions in mm: **155 mm wide x 105 mm deep x 88 mm high**

Code	Temperature ranges for control and safety elements		Weight in Kg
	Adjustable thermostat	Limiter	
CCR-40100	0 - 40 °C	100 °C	1,0
CCR-90100	0 - 90 °C	100 °C	1,0
CCR-200230	0 - 200 °C	230 °C	1,0



FIXED IMMERSION CIRCULAR BASE THREE-PHASIC HEATERS

General characteristics

- IP-54 degree protection against moisture
- Incoloy-800 tube (Ø10 mm for the range SBM and Ø8 mm for the range SBC)
- Connection box AISI 430 and box cover AISI 304.
- Connectors AISI 303, crimped and re-sealed.
- Corrugated tube to protect the leads, 3000 mm long.
- Standard voltage 3~230 V Δ, 3~400 V Δ

Applications

- Degreasing
- Chemical industries.
- Cleaning.
- Sea-food boilers
- Boilers
- Fish farms
- Saline solution heating

NOTE: To ensure a good system operation and prolonging heating element life we advise you to install protection elements such as fluid level controls (See pages 149, 150 and 151) and temperature controller (See our general Forcosa catalogue n° 927)



MODELS SBM.

Code	Watts	W/cm²	Material tube	Dimensions in mm			Electricfor's constructive thermic class	Weight in Kg
				A	ØB	L		
SBM6	6000	3	Iy-800	529	370	442	T-602-S	5,4
SBM12	12000	2,9	Iy-800	414	560	327	T-602-S	7,4

Option

- Clamps to fix the heater to a double omega shaped tank. They will be supplied in bags of six units with six screws M4x25 Stainless Steel.
Code: 128169000 **Reference:** MPA-BO-SBM
- Special order: Other dimensions, power and voltages.
 Manufacturing in titanium tube Ø10,92mm
 Manufacturing in Teflon® tube Ø12 mm.

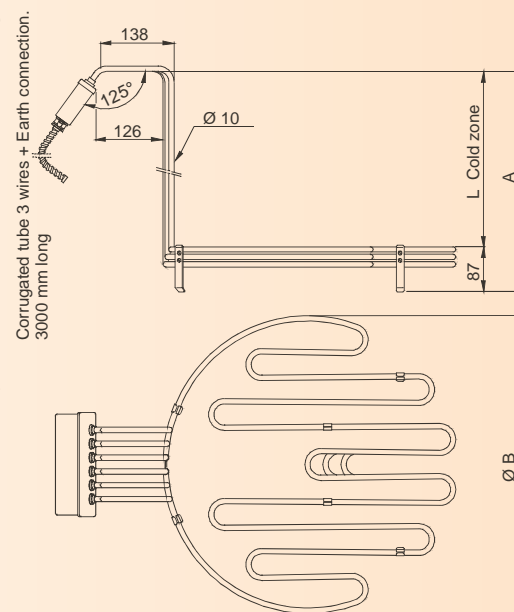

MODELS SBC.

Code	Watts	W/cm²	Tube material	Dimensions in mm					Electricfor's constructive thermic class	Weight in Kg
				A	ØB	L	C	D		
SBC2,5	2500	1,7	Iy-800	438	235	351	40	70	T-602-S	3,2
SBC7,5	7500	2,4	Iy-800	690	425	612	57	97	T-602-S	5,1

Option

- Clamps to fix the heater to a double omega shaped tank. They will be supplied in bags of six units with six screws M4x25 Stainless Steel.
Code: 128170000 **Reference:** MPA-BO-SBC
- Special order: Other dimensions, power and voltages.
 Manufacturing in titanium tube Ø10,92mm
 Manufacturing in Teflon® tube Ø12 mm.

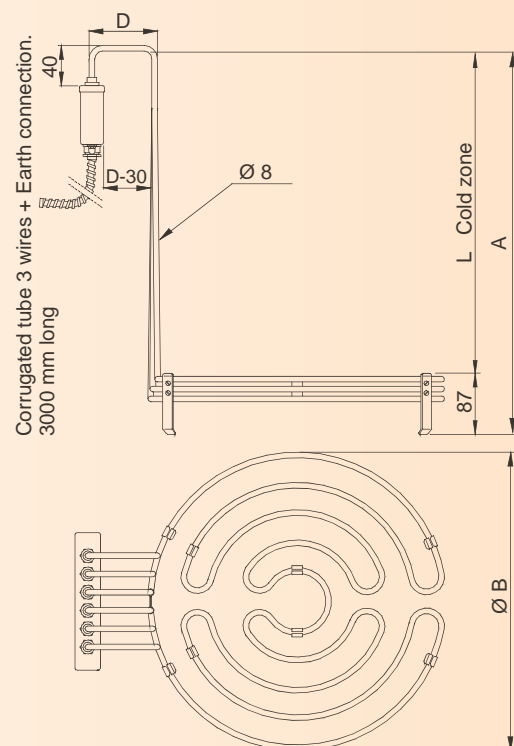

The SBM and SBC models are stocked in finished or semi-finished version in order to be adaptable to several different uses.

If you require, we can also supply the SB type heaters varying side A height to make a special attitude, according to the diagrams, to facilitate fixing the containing baskets in the heating barrels. Specify dimensions A, C, D, E and F in the order.

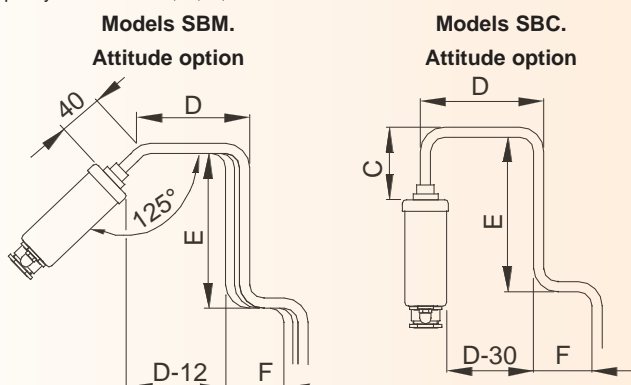



L-SHAPED FIXED HEATERS WITH HANDLE

General characteristics

- Degree protection against moisture IP-20.
- Stainless steel AISI 316L Ø10 mm tube.
- All models incorporate hose cable type H07RN-F with 3 wires of suitable section and length 1500 mm.
- Stocked in finished or semi-finished version in order to be adaptable to several different uses.
- The standard version has the shape of an "S" with handle.
- Standard voltage ~230 V

Options

Shape: «V», «X», «Y».
 Handles: Made in melted resin IP-67
 Connection box with degree protection against moisture IP-66
 Internal plug for 1, 3 or 6 elements.

Also available: Other dimensions, voltages and powers.
 Titanium Ø10,92 mm tube

If you require to reduce the SN heater heights, indicate the dimension Ls, Lv, Ly, Lx on your order sheet

SN HEATERS. STANDARD MODELS

Code	Watts	W/cm ²	Common		Dimensions in mm				Electricfor's constructive thermic class	Weight in Kg
					Shape S	Shape V	Shape Y	Shape X		
					Ls	Lv	Ly	Lx		
SN001	1500	3,3	320	70	450	587	600	931	T-301-E	1,0
SN002	3000	3,1	320	160	450	587	600	931	T-301-E	2,0
SN003	4500	2,9	320	250	450	587	600	931	T-301-E	2,6
SN004	2000	3,9	270	70	850	981	1000	1275	T-301-E	1,9
SN005	4000	3,9	270	160	850	981	1000	1275	T-301-E	2,3
SN006	5700	3,8	270	250	850	981	1000	1275	T-301-E	2,9

Fixation clamps for heaters SN, SL and SF

- Clamps to fix the heater SN to a double omega shaped tank. Material AISI 430. They will be supplied in bags of two units with two screws M4x25 Stainless Steel.

Code: 128171000

Reference: MPA-BO-SN

Other solutions with standard SN elements

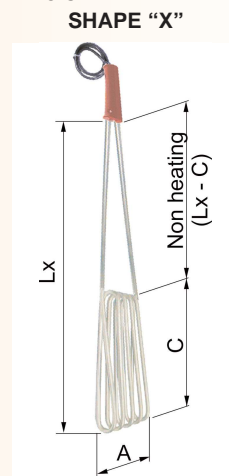
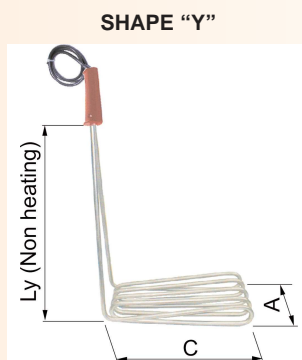
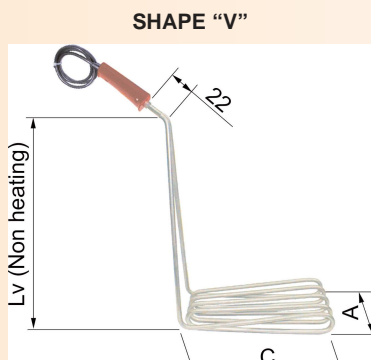
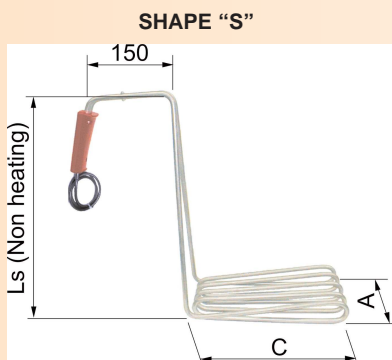

SL HEATERS. STANDARD MODELS

Code	Watts	W/cm ²	Tube material	Dimensions in mm			Electricfor's constructive thermic class	Weight in Kg
				L	LC	Passes through Ø		
SL0,6	600	5,6	AISI 321	295	170	120	T-600-S	0,46
SL1	1000	5,9	AISI 316L	400	105	50	T-301-E	0,56
SL1,5	1500	6,6	AISI 316L	400	105	50	T-301-E	0,61

SL FIXED HEATERS

General characteristics

- Degree protection against moisture IP-20.
- Stainless steel AISI 321 Ø8 mm tube for the model SL0,6 and AISI 316L Ø8 mm tube for the models SL1 and SL1,5.
- All models incorporate hose cable type H07RN-F with 3 wires of suitable section and length 1500 mm.
- Standard voltage ~230 V

SF HEATERS. STANDARD MODELS

Code	Watts	W/cm ²	Tube material	Dimensions in mm			Electricfor's constructive thermic class	Weight in Kg
				L	LC	Passes through Ø		
SF001	1000	5,3	AISI 321	1170	148	56,5	T-300-E	1,0
SF002	1500	5,6	AISI 321	1170	148	56,5	T-300-E	1,1
SF003	1200	2,9	AISI 321	840	447	24	T-300-E	1,1

SF FIXED HEATERS FOR DRUMS

General characteristics

- Degree protection against moisture IP-20.
- Stainless steel AISI 321 Ø8 mm tube.
- All models incorporate hose cable type H07RN-F with 3 wires of suitable section and length 1500 mm.
- Standard voltage ~230 V

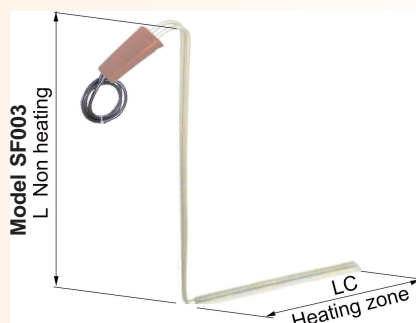
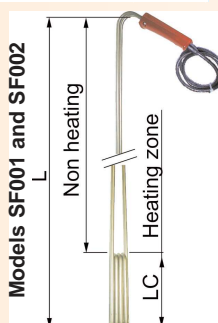
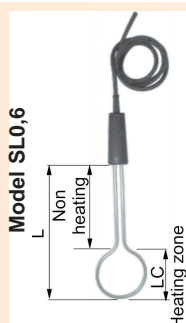
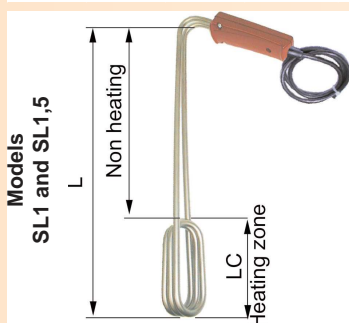

FIXED INSTALLATION HEATING ELEMENTS FOR AGGRESSIVE LIQUIDS.

General characteristics

- Smelted resin handles with degree protection against moisture IP-67.
- Silicone hose cable 2 wires + Earth cable 1500 mm long.
- Electrical Class I
- Standard voltage ~230 V
- Tube material:
 - Titanium Ø10 mm → Models STIU / STIM
 - AISI 316L Ø10 mm → Models SINU / SINM
 - Incoloy®-825 Ø10 mm → Models SIYU / SIYM / SIYMN



TITANIUM HEATERS. SHAPE "U"

Code	Watts	W/cm ²	Dimensions in mm				Electricfor's constructive thermic class	Weight in Kg
			L	I	A	B		
STIU0,5	500	5,0	400	190	160	71	T-440-E	0,70
STIU1	1000	4,3	600	200	350	71	T-440-E	0,86
STIU2	2000	4,9	900	200	650	71	T-440-E	1,1
STIU3	3000	4,8	1250	200	1000	71	T-440-E	1,3
STIU4	4000	4,9	1550	200	1300	71	T-440-E	1,5

STAINLESS STEEL AISI 316L HEATERS. SHAPE "U"

Code	Watts	W/cm ²	Dimensions in mm				Electricfor's constructive thermic class	Weight in Kg
			L	I	A	B		
SINU0,5	500	5,1	400	190	160	71	T-301-E	0,70
SINU1	1000	4,3	600	200	350	71	T-301-E	0,84
SINU2	2000	4,9	900	200	650	71	T-301-E	1,1
SINU3	3000	4,8	1250	200	1000	71	T-301-E	1,3
SINU4	4000	4,9	1550	200	1300	71	T-301-E	1,5

INCOLOY®-825 HEATERS. SHAPE "U"

Code	Watts	W/cm ²	Dimensions in mm				Electricfor's constructive thermic class	Weight in Kg
			L	I	A	B		
SIYU1,5	1500	3,3	1000	250	700	60	T-602-E	1,1
SIYU2	2000	3,3	1300	300	950	60	T-602-E	1,4
SIYU3	3000	3,1	1900	330	1520	60	T-602-E	1,7
SIYU4	4000	3,3	2300	350	1900	60	T-602-E	2,1

TITANIUM HEATERS. SHAPE "M-4"

Code	Watts	W/cm ²	Dimensions in mm				Electricfor's constructive thermic class	Weight in Kg
			L	I	A	B		
STIM2	2000	4,9	600	200	350	158	T-440-E	1,1
STIM2L	2000	4,9	700	200	450	158	T-440-E	1,1
STIM3	3000	4,8	800	200	550	158	T-440-E	1,3
STIM4	4000	4,9	900	200	650	158	T-440-E	1,5

STAINLESS STEEL AISI 316L HEATERS. SHAPE "M-4"

Code	Watts	W/cm ²	Dimensions in mm				Electricfor's constructive thermic class	Weight in Kg
			L	I	A	B		
SINM2	2000	4,9	600	200	350	158	T-301-E	1,1
SINM2L	2000	4,9	700	200	450	158	T-301-E	1,1
SINM3	3000	4,8	800	200	550	158	T-301-E	1,3
SINM4	4000	4,9	900	200	650	158	T-301-E	1,5

INCOLOY®-825 HEATERS. SHAPE "M-4"

Code	Watts	W/cm ²	Dimensions in mm				Electricfor's constructive thermic class	Weight in Kg
			L	I	A	B		
SIYM1,5A	1500	3,3	700	250	400	158	T-602-E	1,1
SIYM1,5B	1500	3,3	800	250	500	158	T-602-E	1,1
SIYM2A	2000	3,3	800	300	458	158	T-602-E	1,4
SIYM2B	2000	3,3	900	300	558	158	T-602-E	1,4
SIYM3	3000	3,1	1150	330	770	158	T-602-E	1,7
SIYM4	4000	3,3	1350	350	950	158	T-602-E	2,1

Applications

- For chemical baths:
- Degreasing
 - Pickling
 - Shining
 - Phosphatizing
 - Electropolishing
 - Zinc-plating
 - Cadmium-plating
 - Copper-plating
 - Nickel-plating
 - Chrome-plating
 - Silver-plating
 - Gold-plating
 - Fixed
 - Colored

COMMON DIMENSIONS. SHAPE "U" RANGE

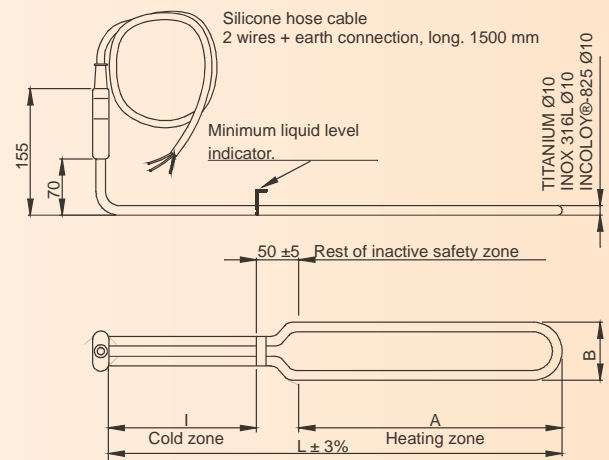

COMMON DIMENSIONS. SHAPE "M-4" RANGE

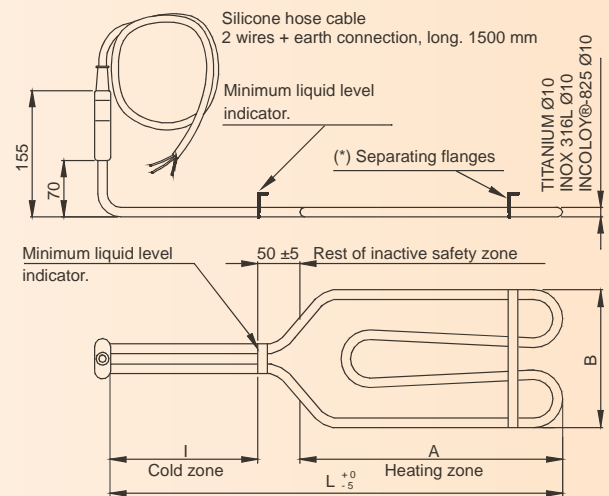

(*) NOTE: The separating flange is only supplied with the models SIYU, SIYM and SIYMN

COMMON DIMENSIONS. SHAPE "M-6" and "M-8"

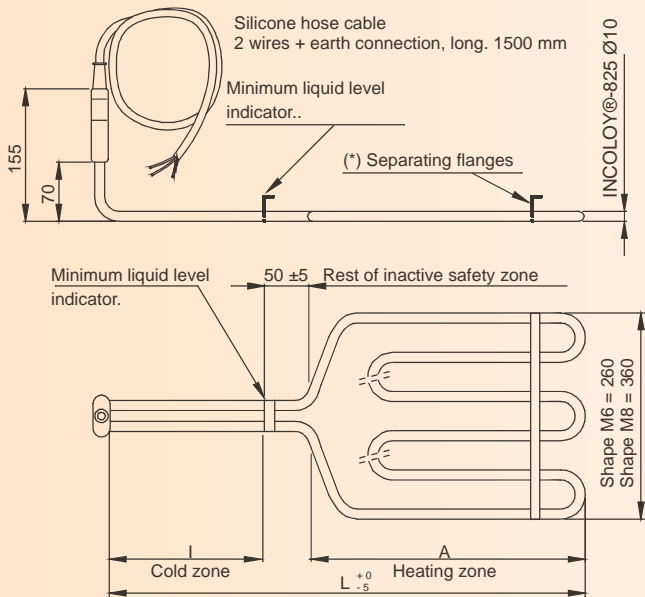

INCOLOY®-825 HEATERS.

SHAPE "M-6" / "M-8"

Code	Watts	W/cm²	Dimensions in mm			Shape	Electricfor's constructive thermic class	Weight in Kg
			L	I	A			
SIYMN1,5	1500	3,3	600	250	300	M6	T-602-E	1,1
SIYMN2	2000	3,3	700	300	350	M6	T-602-E	1,4
SIYMN3C	3000	3,1	800	330	420	M8	T-602-E	1,7
SIYMN3A	3000	3,1	900	330	520	M6	T-602-E	1,7
SIYMN3B	3000	3,1	1000	330	620	M6	T-602-E	1,7
SIYMN4C	4000	3,3	900	350	500	M8	T-602-E	2,1
SIYMN4D	4000	3,3	1000	350	600	M8	T-602-E	2,1
SIYMN4A	4000	3,3	1100	350	700	M6	T-602-E	2,1
SIYMN4B	4000	3,3	1200	350	800	M6	T-602-E	2,1

HEATERS COATED WITH PTFE

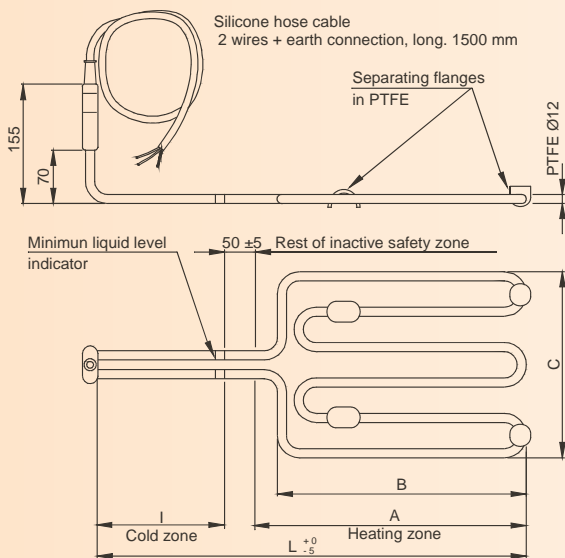

Exclusive for PTFE heaters.

These elements are especially designed to heat a wide variety of corrosive liquids with the exception of hydrofluoric acid. The final choice may be based on the working conditions, recommendations of the manufacturer of the corrosive material, or a preliminary test. ELECTRICFOR, S.A. declines responsibility for any possible problems owing to corrosion, since the different working conditions and factors, which are very often unknown, can affect the effectiveness of the sheath.



ATTENTION! The maximum working temperature is 90 °C for liquids with boiling point below 110 °C, and 35 °C for liquids with boiling point over 110 °C. For more information ask for our NTC 9120.

Code	Watts	W/cm²	Dimensions in mm				Shape	Electricfor's constructive thermic class	Weight in Kg	
			I	A	B	C				
STEF1	1000	2,4	140	210	150	245	400	M6	T-270-E	1,1
STEF2	2000	2,5	180	370	330	245	600	M6	T-270-E	1,5
STEF3	3000	2,5	320	430	390	245	800	M6	T-270-E	2,1
STEF3A	3000	2,6	320	530	380	245	900	M8	T-270-E	2,1
STEF3B	3000	2,5	320	630	510	245	1000	M8	T-270-E	2,1

TERACTE / TERACTI / TERACTY

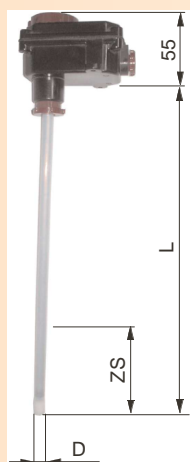

GROUP 11 - Control and regulation

Model	Sheath	Thermostat							
		Assembly code	Material	Dimensions in mm			Sheath replacement code	Assembly code	Material
L	ZS Minimum level Bulb zone			D	Assembly code	Material			
TERACTE3090	PTFE	360	100	12	128046000	30_90	BULB	3501290201	0,34
TERACTI3090	TITANIUM	360	100	12,7	128045000	30_90	BULB	3501290201	0,34
TERACTY3090	IY-825	360	100	12	128206000	30_90	BULB	3501290201	0,34

Replacements

Code	Description
128046000	PTFE SHEATH
128045000	TITANIUM SHEATH
128206000	INCOLOY®-825 SHEATH
108046004	BAKELITE BOX WITH GASKETS
3503290201	THERMOSTAT WITHOUT BUTTON
517165000	BLACK BUTTON. TEMPERATURE RANGE 30 / 90 °C





IMMERSION HEATERS FOR AGGRESSIVE BATHS, RG RANGE.

Immersion heaters for aggressive baths in the RG range are used for heating the different types of substances and solutions of a chemical or electrolytic, surface-coating process

General characteristics

- Heating element manufactured with high-quality ceramic support and Ni-Cr alloy resistive wire
- Head in EPDM for all models with sheath Ø25, Ø30 and Ø33 mm and also for models with lead sheath in Ø52 mm.
- Bakelite head with IP65 protection degree for the porcelain models of Ø40 mm and all models with sheath Ø52 mm except for models with lead sheath.
- 2 or 3 wire silicone hose lead + Earth of 1500 mm long (for different lengths of lead, indicate on the order)
- Class I electric heater
- Standardised voltages: ~230 V; 2~400 V; 3~400 V
- Sheath material:

Titanium	→	Ø25 mm / Ø52 mm	Pyrex	→	Ø52 mm
Quartz	→	Ø25 mm / Ø30 mm	PTFE	→	Ø52 mm
AISI 316L	→	Ø33 mm / Ø52 mm	Lead	→	Ø52 mm
Porcelain	→	Ø40 mm			

Applications

- Chemical baths for:
- Degreasing
 - Bead-polishing
 - Polishing
 - Phosphate-plating
 - Electro-polishing
 - Zinc-plating
 - Cadmium-plating
 - Copper-plating
 - Nickel-plating
 - Chrome-plating
 - Silver-plating
 - Gold-plating
 - Fixing
 - Colouring

Method of use

- The immersion heater is supplied without any control elements, the user having to connect the different electrical circuits and drives to start the immersion heater running.
- Periodically check the air-tightness of the head to make sure there is no deterioration of the internal connections due to corrosive actions of vapours or liquids.
- The immersion heater has a mark which signals the heated zone. To ensure correct functioning, it is vital that this mark is always completely submerged
- For its electrical connection, it must be submerged in the bath.
- To remove it from the bath, it must be disconnected electrically and left for 15 minutes or until the heating element has cooled down.
- Before installing the immersion heater, check that the sheath material is suitable for the type of bath in which it is to be submerged. To do so, and only as a guideline, we show below a table with the recommended sheath materials per type of bath. The final choice may be based on working conditions, recommendations by the corrosive material manufacturer, or else, on a preliminary test. ELECTRICFOR S.A. cannot be held responsible for potential problems caused by corrosion, as different working conditions and other factors, often unknown, can modify the efficiency of the sheath.

	Titanium	Quartz	Stainless Steel AISI 316 L	Porcelain	Pyrex	Lead
Electro-acid shining		X		X	X	X
Cadmium	X		X			
Alkaline copper	X		X			
Acid copper	X	X		X	X	X
Colouring			X			
Special chrome						X
Sulphuric chrome						X
Sulphurous chrome	X	X		X	X	
De-greasing	X		X			
Aggressive de-greasing		X		X	X	
Staining steel electro-polishing		X		X	X	
Aluminium electro-polishing		X		X	X	X
Fixing		X		X	X	X
Phosphate-plating	X		X			
Shiny nickel-plating			X			
Silver-plating	X	X		X	X	
Gold		X		X	X	
Alkaline zinc	X		X	X	X	
Salts for thermal treatments (nitrates - sodium nitrates)			X			

NOTE

The special characteristics of Teflon make it able to work in a wide range of corrosive liquids, and would therefore be suitable for any of the baths indicated in the table included.

The exception is to be found in baths with hydrofluoric acid or solutions with fluoride base. In these cases, Teflon is NOT appropriate

Standar models

Figure nº	Ø sheat	Sheat material	Long. A in mm							
			500	525	600	750	800	900	1000	1200
1	Ø25	TITANIUM	1000 W	--	--	--	2000 W	--	3000 W	--
1	Ø30	QUARTZ	1000 W	--	--	--	2000 W	--	3000 W	--
1	Ø33	AISI 316L	1000 W	--	--	--	2000 W	--	3000 W	--
2	Ø40	PORCELAIN	1000 W	--	--	--	2000 W	--	3000 W	--
2	Ø52	TITANIUM	--	1000 W	1000 W	2000 W	2000 W	3000 W	3000 W	3000 W
		AISI 316L								
		PYREX								
		PTFE	--	800 W	--	1600 W	--	2400W	--	--
1		LEAD	--	800 W	--	1600 W	--	2400W	--	--

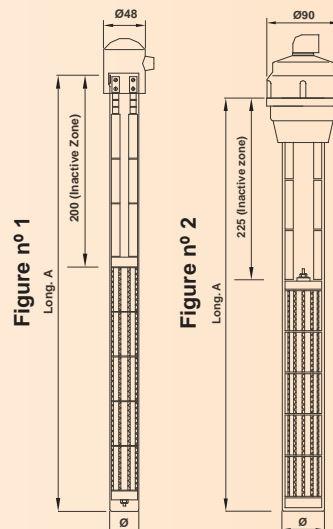

FLAT TEFLON HEATERS FOR AGGRESSIVE LIQUIDS, GVT MODELS

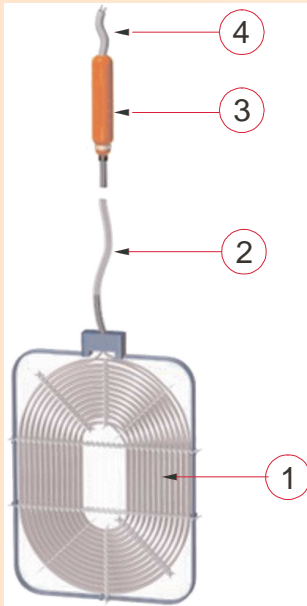

Flat GVT Teflon heaters are especially designed to heat highly aggressive liquids and in cases where reduced dimensions and a substantial heat-power supply are required.

Its Teflon coat (Teflon-FEP or Teflon-PFA) and its low load density (just 1 W/cm²) confer great stability against most aggressive liquids.

The choice of coat (single- or double-layer FEP or PFA) must depend on the working temperature and type of liquid being heated.

The FEP coat can be used in most cases. A double-layer coat is recommended for some applications in heating nitric-acid baths.

The Teflon PFA coat must be chosen in particularly critical conditions, with extremely aggressive liquids and very high liquid temperatures.

The 1 W/cm² load density is adequate for heating up to 90 °C. For working temperatures between 90 and 120 °C, heaters with a load density of 0.5 W/cm² are recommended.

Description

The flat-shaped heating area must always remain submerged.

In continuation of the heating area there is a non-heated support (called "N"), which must remain covered by at least 20 cm of liquid. The two black marks in the N zone indicate the maximum and minimum liquid level.

The N zone is protected by an elastic polypropylene braid.

Behind the N zone there is a connection consisting of an injected-PVC tube with protection grade IP64. A power lead type H05 VV-F or H07 RN-F, according to voltage and power, leads out from the connection hood (called "C"). The connection must be fitted outside the tank and away from the incidence of vapours.

1.- Heating area, which must always remain submerged

2.- N zone (non-heated). Standard length 1000 mm

3.- Connection hood IP64

4.- Power lead C. Standard length 1000 mm

General Characteristics

- Injected-PVC hood IP64

Single-phase heaters: Ø30 mm x 195 mm length

Three-phase heaters: Ø30 mm x 220 mm length

- Coat: One layer of Teflon FEP. Also on request: Teflon FEP with double layer or Teflon PFA with single or double layer.

- 1000-mm long power lead type H05 VV-F for single-phase heaters or type H07 RN-F for three-phase heaters .

- Load density: 1 W/cm²

- Standard voltage ~230 V or 3~400 V

Standardised models**Type A models**

For fitting to side or bottom of tank

With metal frame coated with polypropylene or polyvinyl fluoride

Type B models

With fastener for fitting to side of tank

With metal frame coated with polypropylene or polyvinyl fluoride

Type C models

For fitting to side or bottom of tank

Type D models

For fitting to bottom of tank

Type F models

Universal model for all fitting types whether side or bottom of tank with feet.

Rigid structure is ideal for high power needs.

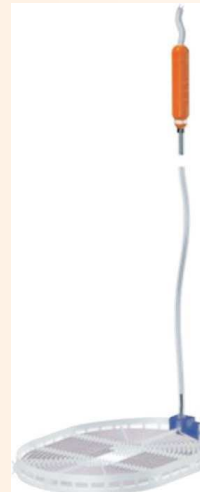
**Accessories****Cables**

Type H05 VV-F
Type H07 RN-F

Packing gland

Ø75 mm packing gland

Available in polypropylene or polyvinyl fluoride

Protective grilles

Polypropylene or polyvinyl-fluoride perforated plastic grille

Feet

For fitting to tank floor.

Available in polypropylene or polyvinyl fluoride



HEATER CMG WITH VERY LOW DENSITY LOAD FOR HYDRAULIC OIL GROUPS

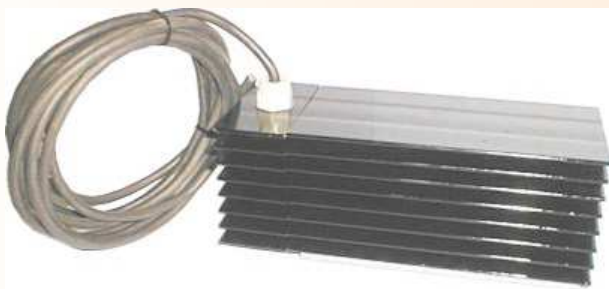

The CMG heater is designed for maintaining temperature in tanks of hydraulic oil or other materials in which a stable temperature of approximately 25 °C is needed (starting up of hydraulic groups, etc.).

Thanks to the large surface of the aluminum radiator we obtain a really low density load of the heater, ensuring a maximum surface temperature of the element of 60 °C, even working dry. In this way we avoid risks of oil cracking, prolonging the element life.

The heater incorporates two powerful magnets which, apart from being used to fix a position in the metallic tank, attract potential small magnetic particles in suspension that could damage the hydraulic groups.

General characteristics

- Degree protection against moisture IP66.
- Profile in black aluminum.
- Supports base in galvanized steel with two powerful magnets to fix the resistance to metallic deposits and at the same time to attract metallic particles in suspension.
- Fixed temperature thermostat at 28 °C with differential of 11 °C.
- Silicone hose cable of 3x0,75 mm² with PG9 for tank exit
- PG9 for cable hose.
- Watertight gaskets.
- Option: If you require, we can supply finished CMG heater with 3/8" pressure connection with metallic mesh of 1200 mm length

Usual applications

- Hydraulic oil baths
- Positioners
- Lifts
- In general, all baths that need a stable calorific input to maintain a temperature of 25 °C.

Code	Volts	Watts	W/cm ² (*)	Weight in Kg
CMG020	~230	200	0,14	2,6

(*) The load density of the apparatus is taken with respect to the aluminium radiator.

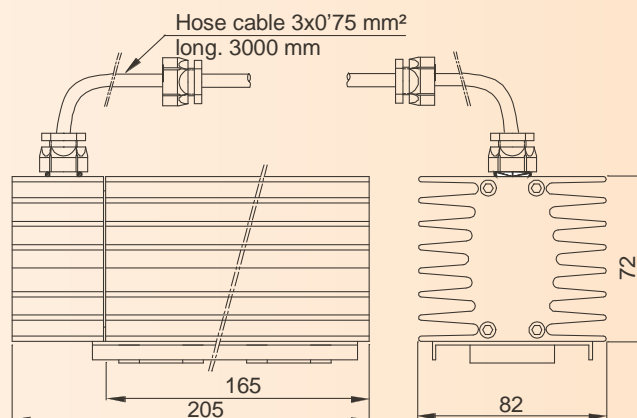

METALLIC HEATING CLAMP FOR DRUMS



“AF” RANGE

Very robust construction based on elements with stainless steel AISI 321 or 304L tube covered with a galvanised steel layer.

General characteristics

- Standard model for drums 200 Lts (Ø580 mm).
- Tubular elements with stainless steel AISI 321 or AISI 304L tube.
- The outside of the clamp is insulated by a mineral sheet protected by a galvanised layer.
- Closing with double buckle.
- Power: 1,3 KW (2x650 W)
- Standard voltage ~230 V
- Other dimensions and voltages are available on request

Code	Dimensions in mm		Watts	W/cm ²	Tube material	Electricfor's constr. thermic class	Weight in Kg
	Øint.	Wide					
AF001	580	120	2x650	1,77	AISI 321 ó 304L	T-700-T	5,7

Method of use

- Place the clamp as low as possible on the drum, making sure that the contact with its surface is good. (Do not place on the ridged rigidifiers).
- Check that the level of the liquid is higher than to the position of the clamp. If you foresee variations in the liquid level within the drum, see our magnetic level switches and our level controllers for conducting liquids, solids and granulates (See pages 149, 150 and 151). This eventuality is of special importance when the drums are made of plastics or derivatives, given the fact that using the clamp with an inadequate level in the drum could lead to its premature deterioration.
- Check the highest temperature to which you can raise the liquid, and if necessary, place a thermostat within the drum and make the relevant connections. (To choose the thermostat, see Division Forcosa nº 927 of our general Catalogue and the present catalogue page nº 32, if they are aggressive liquids).
- Do not cover the drum hermetically. The heating of liquid with the drum closed could cause a rise of the pressure inside it. If it is not possible, we suggest that you place a pressostat that will limit the pressure in the drum. (see Division Forcosa nº 927 of our general Catalogue).

FLEXIBLE SILICONE HEATING BANDS FOR DRUMS

“AFBS” RANGE

- The AFBS silicone heating bands are thin, light, water and ozone proof and allow you to heat surfaces metallic resistors could not heat easily.
- The AFBS silicone heating bands stick to the drum thanks to a system of elastic springs located on the ends. Thanks to its flexibility, the heating band adapts to the surface of the drum, thus improving on the performance of conventional clamps because it avoids the creation of air bubbles that act as thermal insulators.



General characteristics

- Thermal range: Up to +180 °C under continuous regime. Overtemperature +230 °C in peaks.
- Standard voltage ~230 V
- Class II
- Thickness: between 0,7 mm and 1,5 mm.
- Tolerance: Up to 150 mm + 0,15 mm
Over 150 mm: ± 0,31 mm
- Available Options
 - Built-in thermocouples, thermostats and thermal fuses.
 - Voltage: up to 480 V.
 - Limit W/cm²: possibility of density load up to 5,5 W/cm² with the adequate applications and in controlled conditions.
 - Optional: With an acrylic self-adhesive backing.

Code	Safety thermostat fittes	Dimensions in mm		Watts	W/cm²	Weight in Kg
		A	B			
AFBS001	NO	1700	110	800	0,47	0,50
AFBS001T	Si - 90 °C	1700	110	800	0,47	0,50

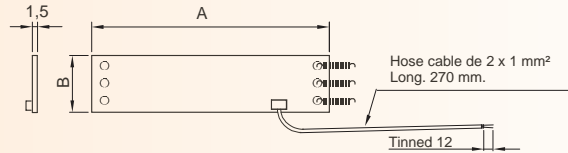

“AFAFS” RANGE

- The AFAFS band heater due to their conception (resistive thread under vulcanized silicone), allow an extraordinary flexibility of use.
- The dimensions of the AFAFS bands cover most standard drums.
- The installation in drums of specific dimensions is possible due to the fixing system.



General characteristics

- Temperature range: +180 °C in continuous use.
- Adjustable thermostat 20 °C to 180 °C protected by silicone.
- Silicone connection cable 2000 mm long.
- Material support: Rubber, silicone plus fiber glass with laminated metallic iron strap.
- Class II.
- Standard voltage ~230 V

Code	Dimensions in mm (Wide x Length)	Suitable for Ø drum	Capacity	Watts	Weight in Kg
AFAFS20	96 x 850	275 / 300	20 Lts	400	0,50
AFAFS55	96 x 1100	295 / 355	55 Lts	750	0,65
AFAFS200	96 x 1700	550 / 600	200 Lts	1000	0,80

“AFHSSD” RANGE

- The AFHSSD silicone side drum heater is a simple and effective method of applying heat to drums and multiple units up to a maximum of three can be used to give quicker warm up times and higher product temperatures. The AFHSSD is specifically designed for the melting or reducing the viscosity of soaps, fats, varnishes and oil based type products. It can also be used in conjunction with the AFBCB base drum heater to increase product heat up
- The heating element of the AFHSSD is PTFE coated and sandwiched between multiple layers of silicone coated glass fabric
- A simple spring and clip arrangement that ensures good surface contact with the drum.

General characteristics

- Standard voltage ~230 V
- Class II.
- Supply Lead: 1mm² Twin Core rubber insulated conductors – Neoprene sheathed
- Temp. Control: 20° to 120°C adjustable Capillary Thermostat.
- Heater Material: Silicone rubber / Glass fibre sheet – Double Insulated Construction

Code	Thermostat temperature range	Drum capacity	Dimensions in mm		Watts	Weight in Kg
			Wide x Length.	Heating length		
AFHSSD25	20 / 120 °C	25 Lts	125 x 800	690	300	0,80
AFHSSD50	20 / 120 °C	50 Lts	125 x 940	830	500	0,83
AFHSSD105	20 / 120 °C	105 Lts	125 x 1300	1125	800	1,0
AFHSSD200A	20 / 120 °C	200 Lts	125 x 1665	1490	1000	1,2
AFHSSD200B	20 / 120 °C	200 Lts	180 x 1665	1490	1000	1,5
AFHSSD200C	20 / 120 °C	200 Lts	180 x 1665	1490	1500	1,5

INSULATION JACKETS FOR DRUMS

“AFCHA” RANGE

The AFCHA insulation jacket can be used in conjunction with all the drum heaters in the Electricfor range.

- When used with AFBCB and AFBS001T side drum heaters, it can be fitted during heating to reduce warm up time and increase the top range temperature attainable.
- When used with the AFBS, AFAFS and AFCCB side drum heaters, it can be fitted after heating to maintain the temperature for a longer period of time.

General characteristics

- Jacket made from a water resistant, flame reatrdant, polyurethane nylon.

Code	Drum capacity	Weight in Kg
AFCHA25	25 Lts	0,40
AFCHA50	50 Lts	0,62
AFCHA105	105 Lts	1,2
AFCHA200	200 Lts	2,4



FLEXIBLE HEATING BLANKETS FOR DRUMS, AFCCB RANGE 

The AFCCB side drum heaters are a simple and effective method of applying heat to drums. Four standard sizes are available for drums 25L, 50L, 105 Lts and the more common 200 Lts.

The AFCCB is specifically designed for use with plastic drums but can be used on any containers where delicate materials require gentle warming.

It can also be used in conjunction with the AFBCB base drum heater to increase product heat up. Non-standard sizes are also available upon request

AFCCB side drum heaters are specifically designed for the melting or reducing the viscosity of soap's, fats, varnishes and oil based type products.

All AFCCB heaters incorporate their own thermic insulation in order to increase thermic efficiency.



General characteristics

- Standard voltage: ~230 V
- 3 Meter Braided Power Cable.
- Class II
- Adjustable thermostat 0 / 90 °C. On demand with adjustable thermostat 0 / 40 °C.
- Outer jacket of nylon polyurethane. IP-40
- Flame-retardant polyester insulation.
- Quick release buckles for easy installation and removal.

Code	Temperature thermostat range	Drum capacity	Dimensions in mm			Watts	Weight in Kg
			Length	Wide	Heating length		
AFCCB25	0 / 90 °C	25 Lts	1020	400	870	200	3,3
AFCCB50	0 / 90 °C	50 Lts	1250	460	1100	250	4,0
AFCCB105	0 / 90 °C	105 Lts	1650	370	1500	400	5,3
AFCCB200	0 / 90 °C	200 Lts	1950	450	1800	450	6,3
AFCCB200B	0 / 90 °C	200 Lts	1950	800	1800	1200	12,0



FLEXIBLE HEATING BLANKETS FOR DRUMS, AFHTB RANGE 

- The AFHTB side drum heater has the same design and construction as the AFCCB but instead of polyurethane nylon as the jacket material, it uses a silicone impregnated glass cloth: up to 200 °C.
- Four standard sizes are available – 25L, 50L, 105L and most popular the 200L.
- All four sizes of drum heaters AFHTB have their own internal insulation to aid thermal efficiency.
- AFHTB side drum heaters are specifically designed for melting or reducing the viscosity of products that require higher temperatures that can be achieved with the AFCCB type.
- Designed to work in METALLIC drum.

General characteristics

- Standard voltage: ~230 V
- Class I
- 3 Meter Braided Power Cable.
- Degree protection against moisture IP40
- 20° to 220° C Thermostat.

- Silicone/Glass Fabric Jacket.
- Water resistant and a great variety of chemical agents.
- Attachment to the drum is by adjustable quick release buckles.
- Other sizes and ratings are also available upon request

Standard models

Code	Temperatura thermostat range	Drum capacity	Dimensions in mm			Watts	Weight in Kg
			Length	Wide	Heating length		
AFHTB25	20 / 200 °C	25 Lts	1020	400	870	380	3,3
AFHTB50	20 / 200 °C	50 Lts	1250	460	1100	450	4,0
AFHTB105	20 / 200 °C	105 Lts	1650	370	1500	700	5,3
AFHTB200	20 / 200 °C	200 Lts	1950	800	1800	1200	6,3

FLEXIBLE HEATING BLANKETS FOR DRUMS, RANGE AFHSP 

Used to achieve product temperatures at multiple levels and up to 220 °C this jacket provides the industry standard for handling products such as waxes, soaps and materials with high water content.

The outer material of this heater not only performs in heating these solutions but can also specifically target applications for the chemical, acid and food handling.

Constructed with an outer layer of PTFE coated glass fabric the AFHSP has excellent thermal transfer properties and presents a great solution for maintaining consistent product temperatures of innumerable applications

General characteristics

- Standard voltage: ~230 V
- Degree protection against moisture IP40
- Cable supply HO7RN-F with 4000 mm long.
- Adjustable thermostat range 0/90 °C ó 20/200 °C.
- Jacket material. PTFE coated glass fibre cloth
- InsulationE-glass fibre blanket.

- High temperature polyester webbing with quick release adjustable buckles.
- The PTFE material is intended for use with all food stuffs, under any contact time and temperature conditions not exceeding the maximum operating temperature mentioned in each datasheet.
- PTFE Material: Regulatory statement for coated fabrics used in contact with food available on request



Standard models

Code	Temperature range thermostat	Drum capacity	Dimensions in mm			Watts	Wight in Kg
			Length	Wide	Heating length		
AFHSP200	0 / 90 °C	200 Lts	1950	800	1800	1200	6,3
AFHSP200-220	20 / 220 °C	200 Lts	1950	800	1800	1200	6,3

Method of use for flexible heating blankets AFCCB, AFHTB and AFHSP

- Check the maximum temperature to which the fluid can be heated
- It is recommended that the unit be operated in a dry environment with the drum ventilated to avoid build up of internal pressure. If this circumstance is not possible, it is recommended to place a presostat that limits the pressure inside the drum. Consults our n° 927 Forcosa Division general catalogue.
- It is advisable that power to the drum heater be disconnected when the drum is either empty or being filled, or upon installation or removal of the heater itself





BASE DRUM HEATER WITH ADJUSTABLE THERMOSTAT

“AFBCB” RANGE

The AFBCB base drum heater is specially recommended for reducing viscosity in soaps, greases, varnishes and heavy oils. The base diameter allows it to be used in all drums 200 Lts or higher. If the drums are plastic, in principle do not use, consult our Technical Dept.

The AFBCB base drum heaters are manufactured with a 900W silicone rubber insulated heater mat which provides an even distribution of heat to the plate.

If rapid heat up is required and the contents will accept heat rapidly, or solid medium is involved a AFBS, AFAFS and AFCCB side drum heater can be used in conjunction with the AFBCB; alternatively a thermally insulated jacket can be used.

The AFBCB is made from 2mm thick mild steel for extra rigidity on uneven surfaces with tapered edges for safe use of drum location and is protected by a resilient high temperature coating. Temperature adjustment through a front aperture in the control unit, with the LED indicating power on and load switching. The base drum heater is controlled by a 20° to 150°C capillary thermostat.

General characteristics

- Standard voltage: ~230 V
- Power: 900 W
- Insulation: 50 mm High-density rock wool
- Adjustable thermostat 20 / 150 °C with ON/OFF LED indicator.
- Supply Lead: 2 Metres flexible armoured SY type 3-core cable
- Weight: Approximately 15 Kg
- Dimensions

- Plate

Base Ø 600 mm Diameter top 550 mm Height 70 mm

- Control unit

Protrusion 280 mm Height 105 mm

- Overall unit

Wide 600 mm Length 880 mm Height 105 m

Code	Volts	Watts	Weight in Kg
AFBCB001	~230	900	15,0

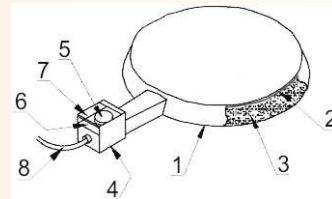

Construction

- 1.- Drum heater base
- 2.- Heater mat
- 3.- Thermal Insulation
- 4.- Thermostat & control housing
- 5.- Control knob
- 6.- Control knob access
- 7.- Viewing window
- 8.- Armoured power cable

IBC TYPE 1000 Lts INTERMEDIATE BULK CONTAINER HEATERS. HIBC MODELS

HIBC container heaters are designed to heat products stored in 1000 Litre intermediate bulk containers.



HIBC/A Model

HIBC/A is a silicone mat heater for placement below the container liner before filling. An insulation jacket covering four sides and the lid is also available to aid warm up time. Control is via a 0° C to 90° C Digital Thermostat housed in an enclosure along with a residual current device

General characteristics HIBC/A model

- Standard voltage: ~230 V
- Degree protection against moisture IP55
- A PTC temperature sensor is also embedded between the sheets. It provides accurate measurement and fast response to temperature changes.
- 20°C-90°C Electronic Controller (Digital Readout). Also is possible with 0 / 40 °C electronic controller

NOTE: The electronic controller is supplied independent from the heater.

The insulation jacket is not part of the HIBC/A silicone heater mat and has to be ordered as an extra, if required.

Performance: Water temp. from 15°C to 70°C in 42 hours (NO Insulation Jacket)
Water temp. from 15°C to 70°C in 30 hours (WITH Insulation Jacket)

Insulation jacket HIBC/A characteristics

- Jacket made from a water resistant, flame retardant, polyurethane nylon.
- Quick release buckles for easy installation and removal.

NOTE: Is important determine the exact dimensions of the container in case of order.

Code	Description	Dimensions in mm		Volts	Watts	Weight in Kg
		Wide	Long.			
HIBC/A	Heating element	850	1035	~230 V	2700 W	
HIBC/A-CHA	Insulation jacket	1000	4400	--	--	
HIBC/A-REG	0 / +90 °C Electronic controller			~230 V	--	

HIBC/B Model

The HIBC/B insulated nylon heater jacket has a heating element stitched into an insulated jacket made from a water-resistant, flame retardant, polyurethane nylon, insulated with a double layer of flame retardant needed polyester. The jacket has two separate heating circuits for its upper and lower halves; each circuit is controlled by an integral capillary thermostat.

General characteristics HIBC/B model

- Standard voltage: ~230 V
- Degree protection against moisture IP51
- -5 / 40 °C Adjustable thermostat per circuit. Optionally with +20 / +90 °C adjustable thermostat.
- With release buckles for ease of installation and removal.
- Insulated jacket made from a water-resistant, flame retardant, polyurethane nylon
- Insulated with a double layer of flame retardant needed polyester.
- Performance: Water temp. from 15°C to 55°C in 56 hours (NO Insulation Lid)
Water temp. from 15°C to 80°C in 56 hours (WITH Insulation Lid)

Code	Description	Thermostat temperature range	Dimensions in mm		Volts	Watts	Weight in Kg
			Wide	Long.			
HIBC/B	Heater jacket with insulated lid	-5 / +40 °C	1000	4400	2 x ~230 V	2 x 1000 W	



EPV immersion heaters have been designed for heating liquids and, in wine-making, to facilitate the process of grape juice fermentation.

Totally manufactured in AISI 316L stainless steel and completely watertight for their total immersion in fermentation tanks.

All materials used in their manufacture are suitable to be used in the food industry. To order, special models can be supplied for specific temperatures and uses.

The EPV range of heaters are shielded electric heating elements with power feed only at one end. Available in construction **Class I** (main insulation requiring earth plug) and in construction **Class II** (double insulation or reinforced insulation).

Electricfor offers the possibility of personalising the element as far as size, power and suitable attachments for each manufacturer.

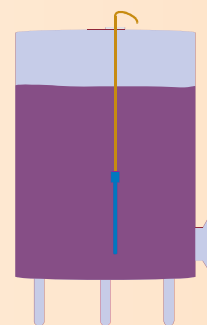

High power immersion heaters, range EPV-GP

General characteristics

- AISI 316L Ø10mm stainless steel pipe.
- Connection box, separators and connection ring in AISI 316L stainless steel.
- Unit surface finish: Electropolished.
- Watertight connections box, with IP-67 damp protection rating.
- Hose connection lead of 4 wires (3-phases + earth) of 2.5mm² section and 10,000 mm long. Non-toxic blue outer covering of the hose lead suitable for food applications.
- Grey polyamide PG16 stuffing box.
- Class I electric element.

Model	Dimensions in mm		Volts	Watts	W/cm ²	Weight in Kg
	Length	Pass through Ømax				
EPV-GP4,5	750	Ø110	3-400 V	4500	1,8	
EPV-GP6	900	Ø110	3-400 V	6000	2,0	
EPV-GP9	750	Ø150	3-400 V	9000	1,8	



Single tube immersion heaters, range EPV-C2

General characteristics

- AISI 316L Ø10mm stainless steel pipe.
- AISI 316L stainless steel totally watertight head (IP-67 damp protection rating).
- Hook integrated into the head and braided support lead to hang up the heating element.
- AISI 316L stainless steel support plate with grey polyamide PG16 stuffing box.
- Hose connection lead of 2 wires of 1mm² section and 10,000 mm long. Non-toxic blue outer covering of the hose lead suitable for food applications.
- Inside the connection box a 60°C NON-resettable (thermal fuse) safety element can be OPTIONALLY included.
- Class I electric element.

Model	Dimensions in mm		Volts	Watts	W/cm ²	Weight in Kg
	Length	Pass through Ømax				
EPV-C2-0,9	1000	Ø29	~230 V	900	2,0	
EPV-C2-1,2	1300	Ø29	230 V	1200	2,0	
EPV-C2-1,35	1450	Ø29	230 V	1350	1,8	



Class I single tube immersion heaters, range EPV-C1

General characteristics

- AISI 316L Ø9.6mm stainless steel tube
- Vulcanised silicone cap, with IP-67 damp protection rating
- AISI 316L stainless steel support plate with grey polyamide PG16 stuffing box.
- Hose connection lead of 2 wires + earth of 1mm² section and 10,000mm long. Non-toxic blue outer covering of the hose lead suitable for food applications.
- Hook integrated into the head and braided support lead to hang up the heating element.
- Class I electric element.



Model	Dimensions in mm		Volts	Watts	W/cm²	Weight in Kg
	Length	Pass through Ømax				
EPV-C1-0,6	1000	Ø15	~230 V	600	2,0	
EPV-C1-0,77	1300	Ø15	~230 V	775	2,0	
EPV-C1-0,85	1450	Ø15	~230 V	850	2,0	

Cup-type immersion heaters, range C

General characteristics

- Heating element of AISI 316L stainless steel Ø10mm tube.
- AISI 316 stainless steel totally watertight head (IP-67 damp protection rating)
- The top of the head includes a female 1/2" Gas thread for connecting to a passing pipe which should be duly connected to the CUP heater to preserve the damp protection rating, prolong and protect connection leads, creating the cold zone and exit to the outside depending on your requirements.
- Two Ø int 8.5 mm probe or thermostat bulb sheaths. The sheaths can be used for implementing control and safety elements, such as cane thermostats or automatic or manual reset temperature limiters.
- Watertight join.
- Class I electric element.



Code	Dimensions in mm				Volts	Watts	W/cm²	Weight in Kg
	C Heating zone	D	ØInt	L				
C405	173	343	280	344	3-400	9000	3,1	4,1

HEATING BLANKETS FOR DRUM



RANGE "AFCCB"

AFCCB tub heating blankets are a simple and efficient way of applying heat to canisters. Available in four standard sizes for 25-litre, 50-litre 105-litre and the most common 200-litre canisters. All AFCCB heaters include their own thermal insulation to increase thermal efficiency.

The most frequent applications of AFCCB thermal blankets are for reducing viscosity and melting soaps, grease, varnishes and heavy oils.

AFCCB heating blankets are specifically designed to be used with heatproof plastic canisters but any container can be employed when delicate materials require gentle heating. They can be used in conjunction with the AFCCB canister heating base for faster heating. Other non-standard sizes are also available to order.



General characteristics

- Supply voltage: ~230 V.
- 3,000 mm long braided connection lead.
- Class II.
- 0/90°C adjustable thermostat. To order, available with 0/40°C adjustable thermostat.
- Outer jacket of nylon polyurethane. IP-40
- Flame-retardant polyester insulation.
- Connection buckles for fast, easy installation.

Code	Temperature thermostat range	Drum capacity	Dimensions in mm			Watts
			Length	Wide	Heating length	
AFCCB25-40	0 / 40 °C	25 Lts	1020	400	870	200
AFCCB50-40	0 / 40 °C	50 Lts	1250	460	1100	250
AFCCB105-40	0 / 40 °C	105 Lts	1650	370	1500	400
AFCCB200-40	0 / 40 °C	200 Lts	1950	450	1800	450



CABINET HEATERS, "CAM" RANGE

- The CAM electric cabinet heater is conceived to provide the necessary heat contribution in cabinets of electrical set-ups and electronic information boards, with the purpose of avoiding the formation of drops of water by condensation of the humidity.
- Among other factors, it stands out by its black anodized aluminium profile that provides a large surface of heat dissipation in relation to size.
- Assembly takes place on rail DIN of 35 mm. In order to facilitate its installation in the cabinet, the cabinet heater CAM incorporates a removable supply connector.
- The casing of the cabinet heater has a double function:
 - It avoids accidental contact with the heat radiator.
 - It causes the «chimney effect». This enables hot air convection upwards that facilitates the distribution and uniformity of temperature inside of cabinet.
- The CAM electric cabinet heaters are provided with a thermal cut-off that automatically disconnects the feeding of the appliance, avoiding overheating inside the cabinet that can affect the operation of the existing electronics.
- As a complement to the safety offered by the limiter already incorporated into the CAM heater, we recommend installation in the controls cabinet of control elements for distribution and control cabinet heaters models EFR, ETF, FZK, FTO and FTS (page nº 45), in order to maintain the required working temperature and humidity level. If you require other types or scales of ambient thermostats, please consult our general Forcosa Division catalogue nº 927.



General characteristics

- Heating element** Linear heating element
- Radiator** Black anodized aluminium
- Housing** Silver anodized aluminium
- Electrical class** Class I
- Connection** 2 x pressure clamps for wire 0'5 - 2'5 mm²
- Mounting** Clip for 35mm DIN rail
- Standard voltage** ~230 V

Example of installation and performance of CAM electric cabinet heater

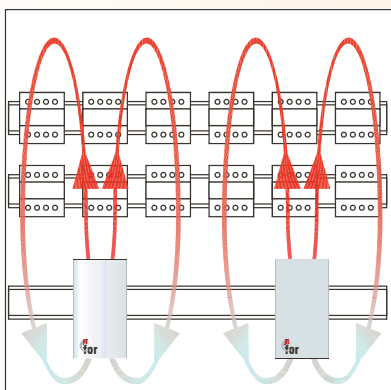

Code	Dimensions in mm		Watts	Weight in Kg
	A	B		
CAM50	98	58	50	0,35
CAM75	138	78	75	0,47
CAM100	178	98	100	0,58

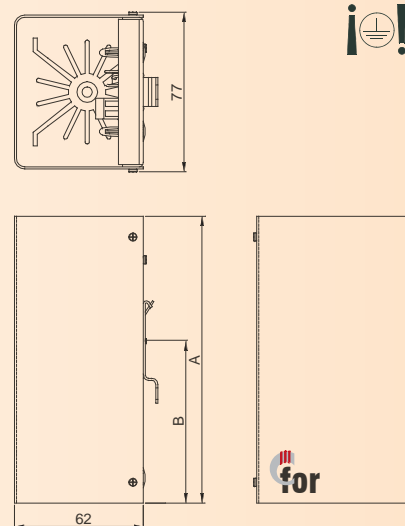

SEMI-CONDUCTOR HEATER, HGK 047 RANGE

General characteristics

- Standard voltage** 150 - 250 V_{ac/dc}. Max 265 V
- Heating element** PTC. Self regulating heating element
- Radiator** Anodized aluminium
- Electrical class** II. Test voltage 4000 V
- Degree protection against moisture** IP54
- Connection** Silicone cable 2x0'75 mm². Length 300 mm
- Mounting** Clip for 35 mm DIN rail, EN 50022
- Fitting position** preferably vertical
- Storage temp** -45 °C (-49 °F) - 70 °C (158 °F)
- Accessories** screw fixing
- Miscellaneous** Operating with voltages below AC/DC 140V reduces heating performance by approx. 10%.
- Standards** VDE, CE

Code	Dim. L in mm	Heating power (T _{amb} =20 °C)	Maximum current	Weight in Kg
HGK04700	50	10 W	approx. 1,0 A	0,10
HGK04701	60	20 W	approx. 2,5 A	0,20
HGK04702	70	30 W	approx. 3,0 A	0,25

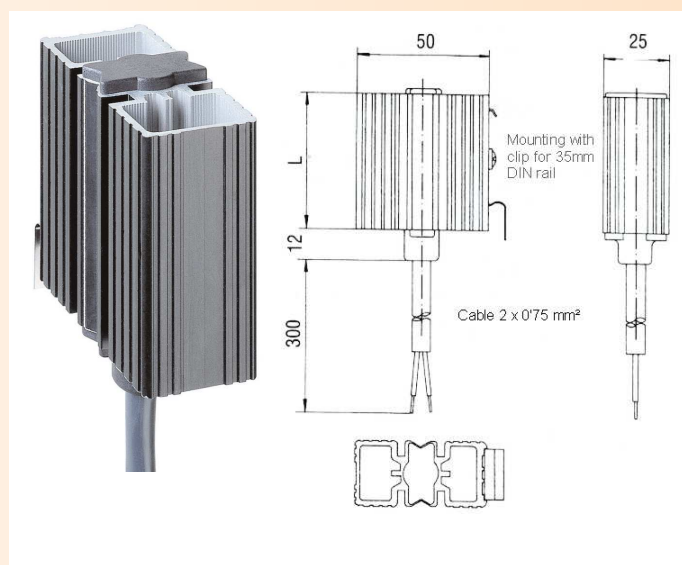

SEMI-CONDUCTOR HEATER, HG 140 RANGE

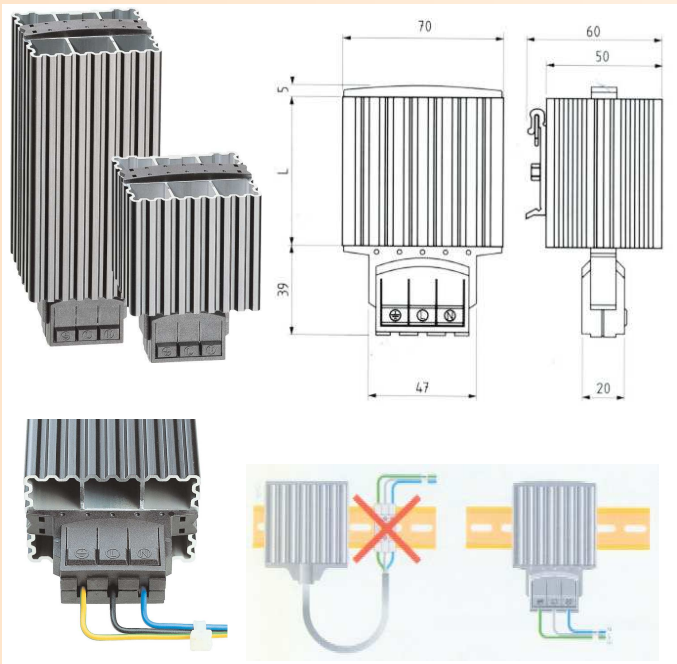

General characteristics

- **Standard voltage** 150 - 250 V_{ac/dc}. Max 265 V
- **Heating element** PTC. Self regulating heating element
- **Housing** Anodized aluminium
- **Electrical class** I (earthed)
- **Degree protection against moisture** IP44
- **Connection** 3 pressure clamps for stranded/ rigid wire 0.5 – 2.5mm²
- **Mounting** Clip for 35 mm DIN rail, EN 50022
- **Fitting position** preferably vertical
- **Storage temp** -45 °C (-49 °F) - 70 °C (158 °F)
- **Standards** VDE, CE
- **Accessories** screw fixing
- **Miscellaneous** Operating with voltages below AC/DC 140V reduces heating performance by approx. 10%

Code	Dimension L in mm	Heating power (T _{amb} =20 °C)	Maximum current	Weight in Kg
HG14000	65	15 W	aprox. 1,5 A	0,30
HG14001	65	30 W	aprox. 3,0 A	0,30
HG14003	65	45 W	aprox. 3,5 A	0,30
HG14005	140	60 W	aprox. 2,5 A	0,40
HG14006	140	75 W	aprox. 4,0 A	0,50
HG14007	140	100 W	aprox. 4,5 A	0,50
HG14008	220	150 W	aprox. 9,0 A	0,70

HEATERS FOR DISTRIBUTION CABINETS WITH PTC HEATING ELEMENT AND THERMOSTAT, CSK 060 RANGE.

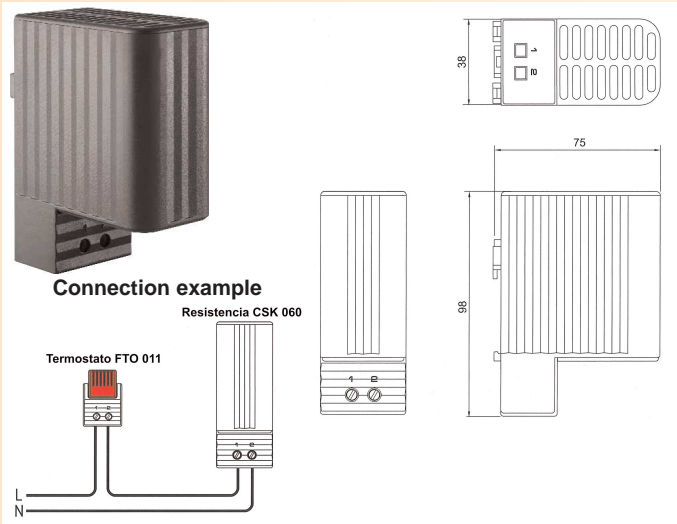

General characteristics

- **Heating element** self-regulating ptc heating element
- **Supply current** 150 - 250V ac/dc. Max 265V
- **Housing** <80 °C (According to VDE 0100), except over top grille
- **Connection** 2 poles, 2.5 mm² terminal
- **Fixing** clip for 35mm DIN rail, EN 60715
- **Mounting position** vertical
- **Storage temp.** -45 °C (-49 °F) - 70 °C (158 °F)
- **Protection degree / class** IP 20 / II (protective insulation)
- **Standardisations** VDE + UL File nº E150057
- **Other technical data** On current below 140V AC/DC, heating power is reduced by about 10%.

Code	Heating power (T _{amb} =20 °C)	Maximum current	Weight in Kg
C SK06010	10 W	aprox. 1,0 A	0,20
C SK06020	20 W	aprox. 2,5 A	0,30

HEATERS FOR DISTRIBUTION CABINETS WITH PTC HEATING ELEMENT AND THERMOSTAT, CSF 060 RANGE

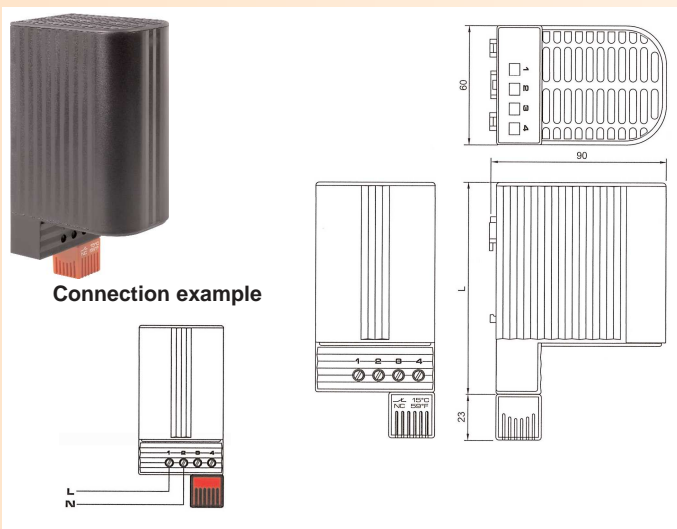

General characteristics

- **Heating element** self-regulating ptc heating element
- **Supply current** 120 - 240 V_{ac/dc}. Max 265 V
- **Surface temperature** <80 °C (According to VDE 0100), except over top grille
- **Housing** Plástico según UL94 V-0, negro
- **Connection** 4 poles, 2.5 mm² terminal
- **Fixing** clip for 35mm DIN rail, EN 60715
- **Mounting position** vertical
- **Storage temp.** -45 °C (-49 °F) - 70 °C (158 °F)
- **Protection degree / class** IP 20 / II (protective insulation)
- **Standardisations** VDE + UL File nº E150057
- **Other technical data** On current below 140V AC/DC, heating power is reduced by about 10%

Code	Heating power (T _{amb} =20 °C)	Maximum current	Thermostat operating temperatures		Weight in Kg
			Deconnection	Connection	
CSF06001	50 W	aprox. 2,5 A	15 ± 5 °C	5 ± 5 °C	0,30
CSF06002	50 W	aprox. 2,5 A	25 ± 5 °C	15 ± 5 °C	0,30
CSF06011	100 W	aprox. 4,5 A	15 ± 5 °C	5 ± 5 °C	0,30
CSF06012	100 W	aprox. 4,5 A	25 ± 5 °C	15 ± 5 °C	0,30
CSF06021	150 W	aprox. 8 A	15 ± 5 °C	5 ± 5 °C	0,50
CSF06022	150 W	aprox. 8 A	25 ± 5 °C	15 ± 5 °C	0,50



HEATERS FOR DISTRIBUTION CABINETS WITH PTC HEATING ELEMENT AND FAN, CS/CSL RANGE

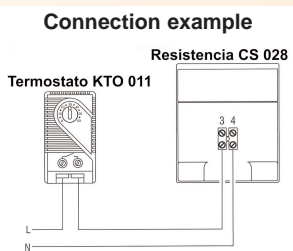

Dimensions model CS 028

Dimensions model CSL 028

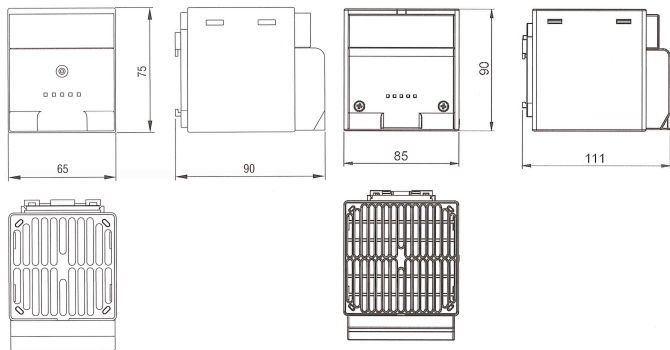

General characteristics

- Heating element self-regulating ptc heating element
- Supply current 230v - 50/60 Hz
- Surface temperature 250W: max 50oC except over top grille
400W: max 65oC except over top grille
- Air flow 45 m³/h at 230 Vac, free discharge
- Ball-bearing axial fan Plastic according to UL94 V-0,black
- Housing 2 poles, 2.5mm2 terminal
- Connection clip for 35mm DIN rail, EN 60715
- Fixing vertical
- Mounting position -45 °C (-49 °F) - 70 °C (158 °F)
- Storage temp. IP 20 / II (protective insulation)
- Protection degree / class VDE + UL File nº E150057
- Standardisations

Code	Heating power (T _{amb} =20 °C)	Maximum current	Weight in Kg
CS02800	150 W	Approx 12 A	0,30
CSL02811	250 W	Approx. 9 A	0,50
CSL02810	400 W	Approx. 15 A	0,50

HEATERS FOR DISTRIBUTION CABINETS WITH PTC HEATING ELEMENT AND FAN, CR 027 RANGE.

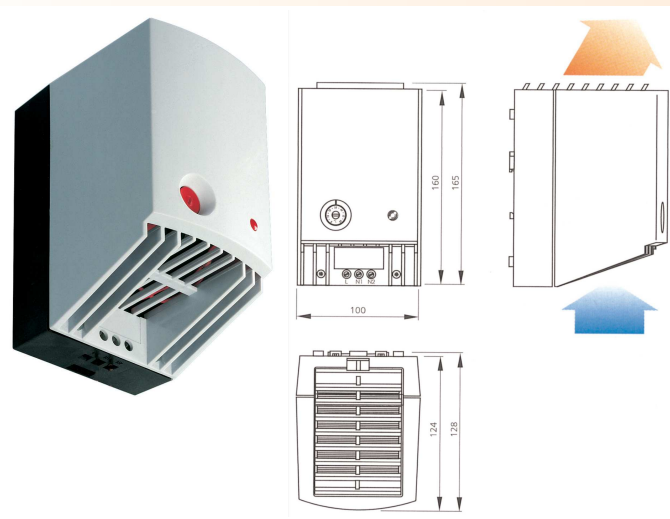

General characteristics

- Heating element self-regulating ptc heating element
- Supply current 220-240V ac - 50 Hz
- Temperature limiter For protection in the event of fan breakdown
- Ball-bearing axial fan Air flow according to model
- Housing Plastic according to UL94 V-0, light grey
- Connection 2 poles, 2.5mm2 terminal
- Fixing clip for 35mm DIN rail, EN 60715
- Mounting position vertical
- Storage temp. -45 °C (-49 °F) - 70 °C (158 °F)
- Protection degree / class IP 20 / II (protective insulation)
- Standardisations VDE + UL File nº E204590

Code	Heating power (T _{amb} =20 °C)	Maximum current	Flow air (free discharge)	Range	Weight in Kg
CR02700	475 W	Approx. 11 A	35 m³/h	0 / 60 °C	0,9
CR02701	550 W	Approx. 13 A	45 m³/h	0 / 60 °C	1,1

HEATERS FOR DISTRIBUTION CABINETS WITH PTC HEATING ELEMENT AND FAN, CS 130 RANGE.

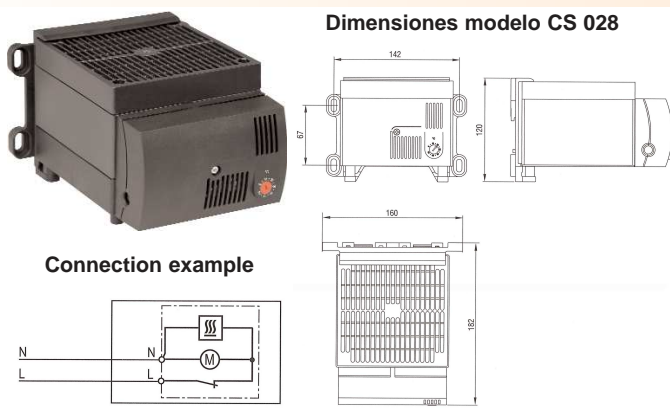

General characteristics

- Heating element self-regulating ptc heating element
- Supply current 230v - 50/60 Hz
- Temperature limiter For protection in the event of fan breakdown
- Ball-bearing axial fan Air flow according to model
- Housing Plastic according to UL94 V-0, light grey
- Connection 2 poles, 2.5mm2 terminal
- Fixing clip for 35mm DIN rail, EN 60715
- Mounting position horizontal
- Storage temp. -45 °C (-49 °F) - 70 °C (158 °F)
- Protection degree / class IP 20 / II (protective insulation)
- Standardisations VDE + UL File nº E204590

Code	Heating power (T _{amb} =20 °C)	Maximum current	Flow air (free discharge)	Range	Weight in Kg
CS13000	1200 W	approx. 13 A	160 m³/h	0 / 60 °C	1,3
CS13001	1200 W	approx. 13 A	160 m³/h	Without thermostat	1,3



LINEAR HEATING ELEMENT WITH AXIAL FAN, HV 031 / HVL 031 RANGE

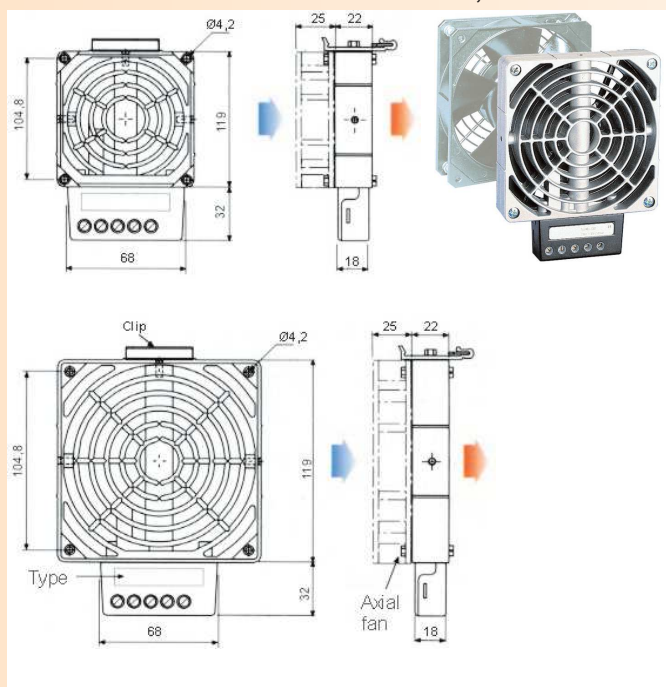

General characteristics

- **Standard voltage** 230 - 250 V_{ac}
- **Heating element** high performance cartridge
- **Heater body** die-cast aluminium
- **Connection box** plastic UL94 V-0
- **Service life** (fan at 25 °C) 50.000 h
- **Connection** 3-pole terminal for 1,5mm²
- **Mounting** Clip for 35 mm DIN rail, EN 50022
- **Fitting position** preferably vertical
- **Storage temp** -45 °C (-49 °F) - 70 °C (158 °F)
- **Degree protection against moisture** IP20
- **Standards** CE UL
- **Miscellaneous** Temperature safety cut-out: to protect against overheating in case of fan failure
- **Axial fan** 5 m³/h free output. (100 and 150 W models) 108 m³/h free output. (200, 300 and 400 W models)
- **Connection for fan** 2 terminals 2'5 mm² (L2/N2)
- **Important:** Heater may only be operated together with fan. Danger of overheating!

Model	Code	External dimensions in mm	Watts	Weight in Kg
Heating element WITHOUT fan	HV03100	80 x 112 x 22	100 W	0,40
	HV03101	80 x 112 x 22	150 W	0,40
	HV03110	119 x 151 x 22	200 W	0,50
	HV03111	119 x 151 x 22	300 W	0,50
	HV03112	119 x 151 x 22	400 W	0,50
Heating element WITH fan	HVL03102	80 x 112 x 47	100 W	0,60
	HVL03103	80 x 112 x 47	150 W	0,60
	HVL03113	119 x 151 x 47	200 W	0,90
	HVL03114	119 x 151 x 47	300 W	0,90
	HVL03115	119 x 151 x 47	400 W	0,90

CREx / REX

GROUP 3 - Electric process heating equipment suitable for hazardous areas

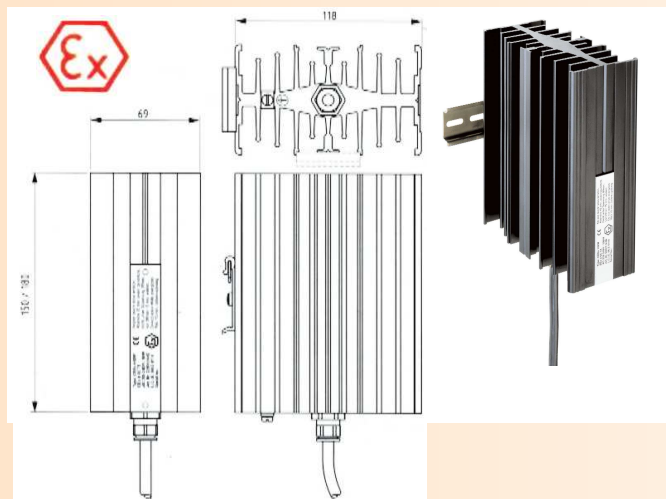

General characteristics

- **Standard voltage** 230 - 250 V_{ac}
- **Heating element** high performance cartridge
- **Radiator** Anodized aluminium
- **Degree protection against moisture** IP65
- **Connection** Si HF-JZ 3 x 0.75mm² cable, length 1m
- **Mounting** Clip for 35 mm DIN rail, EN 50022
- **Fitting position** vertical
- **Storage temp** -45 °C (-49 °F) - 70 °C (158 °F)
- **Explosion protection** LCIE 01 ATEX 6073
- **Standards** EX CE
- **Miscellaneous** Connection PE: 4mm²

Code	EX protection class	T5 Surface temperature	Dimensions in mm	Watts	Weight in Kg
CREx50	EExd IIC T5	100 °C (vertical position)	150 x 118 x 69	50 W	1,3
CREx100	EExd IIC T4	135 °C (vertical position)	180 x 118 x 69	100 W	1,5

Ex THERMOSTAT, REx 0118 RANGE

General characteristics

- **Explosion protection** LCIE 01 ATEX 6074
- **Conformity certificate** 98.E 6109
- **Ex protection type** EExd IIC T6
- **Operating voltage** 250 Vac max. / 100 Vdc max.
- **Connections** Resistive: 4A 250 Vac
Inductive 1A; (cos φ = 0'6) 250V_{ac}
- **Service life** > 100,000 cycles
- **Sensor elements** thermostatic bimetal
- **Connection** Si HF - JZ 3 x 0.75mm², length 1m
- **Mounting** mounting bracket with nut M8
- **Fitting position** variable
- **Degree protection against moisture** IP 65

Code	Operating temperature	Switch difference	Weight in Kg
REx015	15 °C ± 3	4 ± 1 °C	0,20
REx025	25 °C ± 3	4 ± 1 °C	0,20

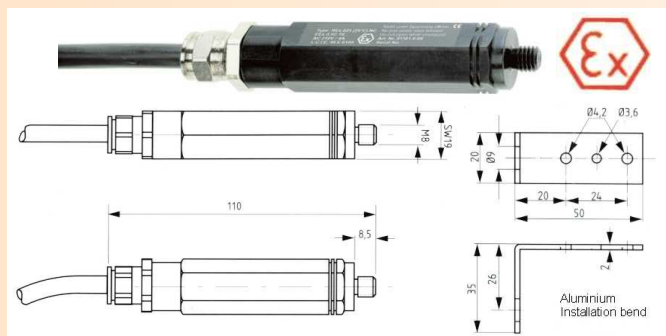

ELECTRONIC HYGROSTAT, EFR 012 SERIES

General characteristics

- **Hysteresis (Humidity)** 5% RH (± 1 RH tolerance) at 25 °C
- **Reaction time** Approx. 5 sec.
- **Contact class** Inverter contact
- **Connection capacity** 240 Vac, 8 (1.6) A
120 Vac, 8 (1.6) A
24 V dc, 4 A
- **Connection** 5 pole flanges, even max 0.5 Nm
- **Housing** plastic according to UL94 V-0, light grey
- **Fixing** clip for 35mm DIN rail, EN 50022
- **Mounting position** vertical
- **Protection class** IP 20

Code	Supply voltage	Range of humidity regulation
EFR01245	230 Vac; 50/60 Hz	40 / 90% RH
EFR01246	230 Vac; 50/60 Hz	Preset adjustment at 65% RH



ELECTRONIC HYGROSTAT, ETF 012 SERIES

General characteristics

- **Hysteresis (Temperature)** 2 °C (± 1 °C tolerance) at 25 °C / 50% RH
- **Hysteresis (Humidity)** 4% RH (± 1 % RH tolerance) at 25 °C / 50% RH
- **Reaction time** Approx. 5 sec.
- **Contact class** Inverter contact
- **Contact resistance** <10 Mohm
- **Connection capacity** NC: 240 Vac, 6 (1) A
NO: 240 Vac, 8 (1.6) A
NC: 120 Vac, 6 (1) A
NO: 120 Vac, 8 (1.6) A
24 V dc, 4 A
- **Connection** 5 pole flanges, even max 0.5 Nm
- **Housing** plastic according to UL94 V-0, light grey
- **Fixing** clip for 35mm DIN rail, EN 50022
- **Mounting position** vertical
- **Protection class** IP 20

Code	Range of temperature regulation	Range of humidity regulation	Weight in Kg
ETF01230	+0 ... +60 °C	50 ... 90% RH	0,20



MECHANICAL THERMOSTAT, FZK 011 SERIES

General characteristics

- **Temperature range** 5 ... 60 °C adjustable
- **Temperature differential** 4 °C \pm 1 °C
- **Sensor** Bimetallic
- **Supply current** 230 - 250 Vac, 50 - 60 Hz
- **Contact class** Commuted contacts
- **Connection capacity** Open contact: Ohmic charge: 10A, 250 Vac
Inductive charge (cos ϕ = 0'6): 4 A; 250 Vac
Closed contacts: Ohmic charge: 5A, 250 Vac
Inductive charge (cos ϕ = 0'6): 2 A; 250 Vac
Flanges on the housing, 4 x 2'5 mm²
- **Connection** light grey plastic
- **Housing** clip for 35mm DIN rail, EN 50022
- **Mounting position** variable
- **Protection class** IP 20

Code	Temperature range	Dimensions in mm	Weight in Kg
FZK011	+5 ... +60 °C	67 x 50 x 38	0,10

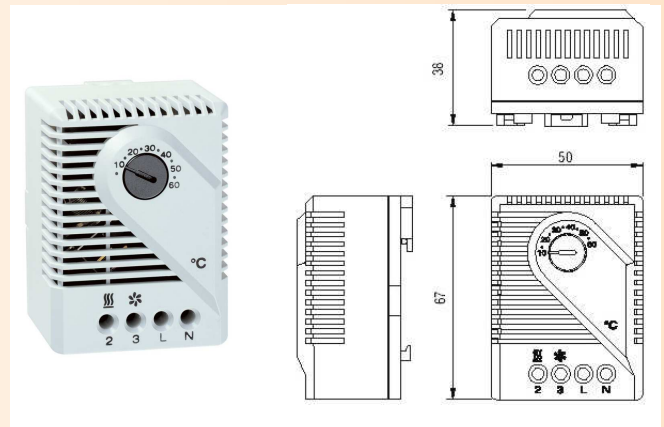

FIXED THERMOSTAT, FTO 011/FTS 011 SERIES

General characteristics

- **Probe** Thermostatic bimetal
- **Contact class** Exhaust contact
- **Contact resistance** <20 Mohm
- **Life length** >100,000 cycles
- **Connection capacity** 250 Vac, 5 (1.6)A
120 Vac, 10 (2)A
30 W dc
- **Connection** 2 poles, terminal 2.5 mm², even 0,8Nm max.
- **Housing** plastic according to UL94 V-0, light grey
- **Fixing** clip for 35mm DIN rail, EN 60715
- **Dimensions** 47 x 33 x 33 mm
- **Mounting position** variable
- **Protection class** IP 20
- **Standardisations** VDE + UL File n° E164102

Code	Contact	Disconnection temperature	Connection temperature
FTO-01160-00	Normally closed	15 °C (± 5 °C)	5 °C (± 5 °C)
FTO-01160-01	Normally closed	25 °C (± 5 °C)	15 °C (± 5 °C)

Code	Contact	Con nection temperature	Disconnection temperature
FTS-01161-00	Normally open	50 °C (± 6 °C)	40 °C (± 7 °C)
FTS-01161-01	Normally open	60 °C (± 6 °C)	50 °C (± 7 °C)
FTS-01161-02	Normally open	35 °C (± 6 °C)	25 °C (± 7 °C)

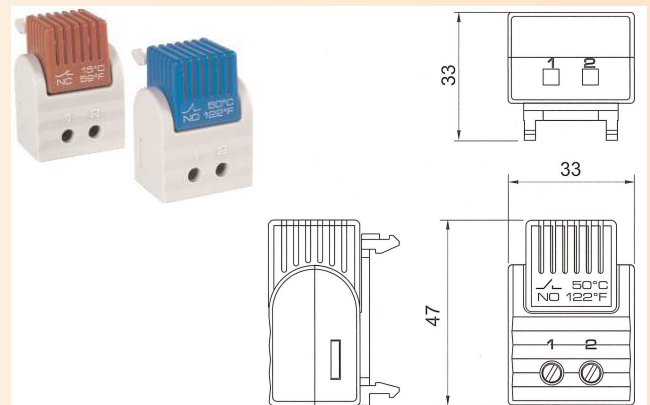

General characteristics

- Tubular elements in stainless steel AISI 321 or AISI 304L Ø8 mm tube for the AL and ALEC range and Ø10 mm tube for ALG range.
- Aluzinc or aluminized sheet fin of 25x50 mm AL and ALEC and 40x70 mm for ALG range.
- Zinc-plated steel crimped connectors
- Standard voltage ~230 V

Options:

- All in stainless steel.
- Round welded fin of Ø30 mm.
- Helicoidal fin:
- * For Ø8mm tube: stainless steel hoop → Ø18, Ø24 steel hoop → Ø23
- * For Ø10mm tube: st. steel hoop → Ø20, Ø26, Ø30 steel hoop → Ø25, Ø30
- To order, other diameters, lengths, power and voltages



Particular characteristics for AL and ALG range

- Maximum temperature with $v_{air} = 2 \text{ m/seg} \rightarrow 200 \text{ }^\circ\text{C}$
- Maximum temperature without forced air ($v_{air} = 0 \text{ m/sec.}$): $60 \text{ }^\circ\text{C}$
- For working temperatures over $60 \text{ }^\circ\text{C}$ you need forced air.
- For working temperatures over $125 \text{ }^\circ\text{C}$ you need to isolate the connection terminals of the heating zone.

Description	Code (1)	Dim. A in mm	Watts	W/cm ² (*)	Electricfor's constructive thermic class	Weight in Kg
Aluzinc or aluminized steel sheet fin of 25x50. AISI 321 or 304L stainless steel Ø8 mm tube Zinc-plated steel M12x1,25 connectors (thread 8 mm long). Dim. C = 5 mm Dim. D = 25 mm	AL010	200	100	1,2	T-600-S	0,29
	AL012	200	150	1,8	T-600-S	0,29
	AL011	200	200	2,5	T-600-S	0,29

Description	Code	Dim. A in mm	Watts	W/cm ² (*)	Electricfor's constructive thermic class	Weight in Kg
Aluzinc or aluminized steel sheet fin of 25x50. AISI 321 or 304L stainless steel Ø8 mm tube Zinc-plated steel M12x1,25 connectors (thread 8 mm long). Dim. C = 5 mm Dim. D = 25 mm	AL001	260	500	4,5	T-700-T	0,38
	AL002	300	600	4,6	T-700-T	0,45
	AL003	370	750	4,6	T-700-T	0,54
	AL004	430	850	4,4	T-700-T	0,62
	AL005	500	1000	4,4	T-700-T	0,71
	AL009	620	1250	4,3	T-700-T	0,88
	AL006	740	1500	4,3	T-700-T	1,1
	AL007	970	2000	4,3	T-700-T	1,4
AL008	1180	2500	4,4	T-700-T	1,5	

Models	Code	Dim A in mm	Watts	W/cm ² (*)	Electricfor's constructive thermic class	Weight in Kg
Aluzinc or aluminized steel sheet fin of 40x70.	ALG01	325	1000	5,3	T-700-T	0,84
	ALG02	470	1500	5,5	T-700-T	1,2
AISI 321 or 304L stainless steel Ø10 mm tube	ALG03	620	2000	5,4	T-700-T	1,6
	ALG04	760	2500	5,4	T-700-T	2,0
Zinc-plated steel M14x1,25 connectors (thread 11 mm long). Dim. C = 5,5 mm	ALG05	910	3000	5,4	T-700-T	2,4
	ALG08 (2)	1090	3333	5,3	T-700-T	2,9
Dim. D = 40 mm	ALG06	1055	3500	5,5	T-700-T	2,8
	ALG07	1180	4000	5,4	T-700-T	3,2

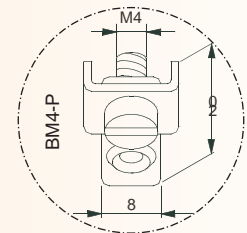
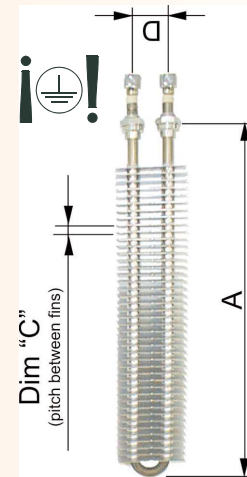

- (1) The finned heating elements range AL010, AL011 and AL012 are designed for electric cabinets and other applications with similar working temperature.
 - (2) Connection with BM6-S-L terminal (thread M6)
- (*) W/cm² are calculated in respect of the element tube

FINNED HEATERS WITH STAINLESS STEEL FINNED AND CONNECTORS.

On order, we can supply the AL and ALG elements with stainless steel fins and connectors. Their code is the same as for the AL and ALG ranges, followed by INOX. To calculate the price of stainless steel finned heaters, multiply the price of the required code by the factors listed below:

- Between 12 and 23 Units → x 2,4
- Between 24 and 59 Units → x 2,2
- Over 60 Units → x 1,9

"ECONOMY RANGE" FINNED HEATING ELEMENTS

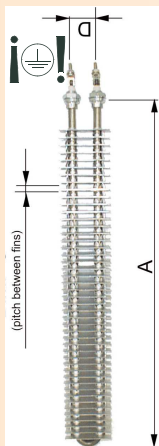
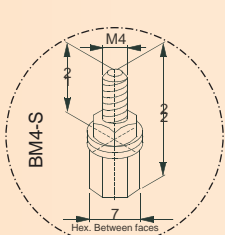

Particular characteristics for ALEC range

- Only for air conditioning, maximum $100 \text{ }^\circ\text{C}$ with $v_{air} = 2 \text{ m/sec}$

Description	Code	Dim. A in mm	Watts	W/cm ² (*)	Electricfor's constructive thermic class	Peso En Kg
Aluzinc or aluminized steel sheet fin of 25x50. AISI 321 or 304L stainless steel Ø8 mm tube Zinc-plated steel M12x1,25 connectors (thread 8 mm long). Dim. C = 5 mm Dim. D = 25 mm	ALEC0,75	270	750	6,6	T-600-S	0,28
	ALEC1	370	1000	6,2	T-600-S	0,38
	ALEC1,5	500	1500	6,7	T-600-S	0,53
	ALEC2	640	2000	6,8	T-600-S	0,68
	ALEC1N	340	1000	6,7	T-600-S	0,35
	ALEC1,33N (3)	340	1334	9,1	T-600-S	0,46



CONNECTION PIVOT

Soldered pivot

Stainless steel pivot soldered to the heating element:

- Ø5 x 13 mm
- Ø5 x 40 mm

New pivot anchoring system for finned heaters

- The pivot, made completely of stainless steel of useful Ø5x40, Ø5x50 or Ø5x60 mm, is fixed to the fins of the heating element by pressure.
- It eliminates soldering, possible breakage of soldered parts and possible rust risks.
- Easy, quick to mount, safer and cheaper.

Code	Reference	Suitable for range	Dim. L (in mm)	Weight in Kg
104113007	BR-ALE-5x40	AL - ALEC	40	0,02
128183000	Bag 24 units BR-ALE-5x40	AL - ALEC	40	0,48
104116007	BR-ALE-5x50	AL - ALEC	50	0,02
128204000	Bag 24 units BR-ALE-5x50	AL - ALEC	50	0,48
104040007	BR-ALE-5x60	AL - ALEC	60	0,02
128205000	Bag 24 units BR-ALE-5x60	AL - ALEC	60	0,48
104118007	BR-ALG-5x50	ALG	50	0,02
128213000	Bag 24 units BR-ALG-5x50	ALG	50	0,48

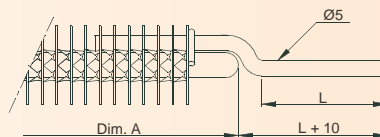

GROUP 2 - Heating elements for air

2.3 - Spiral finned heaters

AHR / AHU / AHM



General characteristics

- Shielded heating elements in AISI 304 of Ø10 mm.
- Stainless steel AISI 304 fin of Ø26 mm. outer diameter
- Ni-Cr alloy resistive wire
- Zinc steel M14 crimped connectors
- Sealed with silicone (up to 200 °C on continuous)
- Threaded connection of M4 or M6 depending on models.
- Standard voltage ~230 V

Options:

- All stainless steel.
- Spiral fin:
- * For Ø8mm pipe: stainless steel finning → Ø18, Ø24 iron finning → Ø23
- * For Ø10mm pipe: stainless steel finning → Ø20, Ø26, Ø30 iron finning → Ø25, Ø30
- Other dimensions, wattages and voltages available to order

Usual applications

- To heat forced circulation air for heating premises, closed drying circuits in heaters, charge benches, etc. In general, for any application of forced air heating up to 200°C (Maximum temperature with $v_{air} = 4 \text{ m/sec} \rightarrow 200 \text{ °C}$) máxima con $v_{air} = 4 \text{ m/seg} \rightarrow 200 \text{ °C}$)

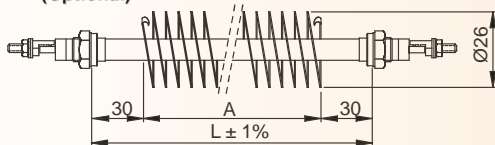

CALEFACTORES ALETADOS HELICOIDALES EN RECTO, MODELOS AHR

Code	Dimensions en mm		Watts	W/cm²	Electricfor's constructive thermic class	Weight in Kg
	Length L	Active zone A				
AHR1000	470	410	1000	8,1	T-700-T	0,28
AHR2000	900	840	2000	7,7	T-700-T	0,53
AHR3000	1320	1260	3000	7,7	T-700-T	0,78
AHR4000	1750	1690	4000	7,6	T-700-T	1,03
AHR5000	2180	2120	5000	7,6	T-700-T	1,29
AHR6000	2600	2540	6000	7,6	T-700-T	1,54

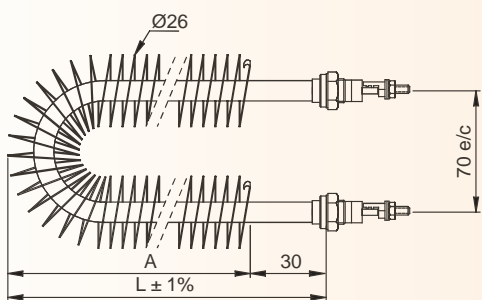

CALEFACTORES ALETADOS HELICOIDALES EN FORMA "U", MODELOS AHU

Code	Dimensions en mm		Watts	W/cm²	Electricfor's constructive thermic class	Weight in Kg
	Length L	Active zone A				
AHU1000	230	200	1000	8,1	T-700-T	0,28
AHU2000	445	415	2000	7,7	T-700-T	0,53
AHU3000	655	625	3000	7,7	T-700-T	0,78
AHU4000	870	840	4000	7,6	T-700-T	1,03
AHU5000	1085	1055	5000	7,6	T-700-T	1,29
AHU6000	1295	1265	6000	7,6	T-700-T	1,54

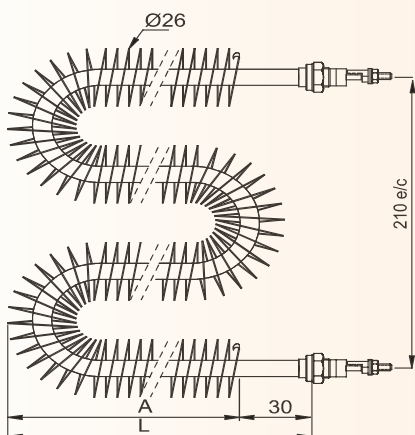

CALEFACTORES ALETADOS HELICOIDALES EN FORMA "M4", MODELOS AHM

Code	Dimensions en mm		Watts	W/cm²	Electricfor's constructive thermic class	Weight in Kg
	Length L	Active zone A				
AHM2000	232	202	2000	7,7	T-700-T	0,53
AHM3000	337	307	3000	7,7	T-700-T	0,78
AHM4000	445	415	4000	7,6	T-700-T	1,03
AHM5000	552	522	5000	7,6	T-700-T	1,29
AHM6000	657	627	6000	7,6	T-700-T	1,54

General characteristics

- Tubular elements of stainless steel AISI 304L or AISI 321 Ø8 mm, insulated with electromelted and lamination-compressed magnesium oxide.
- M13 x 1,25 mm brass connectors, welded to the tube with silver alloy.
- Standard voltage ~230 V

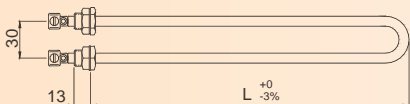

Code	L in mm	Thread	Watts	W/cm ²	Tube material	Electricfor's constructive thermic class	Weight in Kg
U002	260	M13	750	7,5	Stainless Steel	T-600-E	0,17
U003	350	M13	1000	7	Stainless Steel	T-600-E	0,21
U004	520	M13	1500	6,6	Stainless Steel	T-600-E	0,28
U005	680	M13	2000	6,5	Stainless Steel	T-600-E	0,35

Method of use

To ensure a correct functioning of these elements you must bear in mind the following parameters:

- Minimum air velocity: **6 m/sec.**
- Maximum air temperature: **40 °C.**

General characteristics

- Tubular elements of stainless steel AISI 304L or AISI 321 Ø8 mm, insulated with electromelted and lamination-compressed magnesium oxide.
- Terminals BM4-S (Thread M4).
- Standard voltage ~230 V



Applications

- Air conditioning.
- Due to the low watt density of maximum 3,6 W/cm² you can use these elements for heating air to a maximum temperature of 200 °C with an air velocity of v_{air} = 2 m/seg over the heating zone.
- In attached table you can see the maximum working temperature according to the air velocity through the heating elements

W/cm ²	Air at rest	Air at 1 m/seg In element area	Air at 2 m/seg In element area	Air at 3 m/seg In element area	Air at 4 m/seg In element area
3,6	NO	90 °C	200 °C	270 °C	325 °C
Maximum ambient temperature in element area					

“U” Shape elements. UST Range

Code	Dim. A in mm	Watts	W/cm ²	Electricfor's constructive thermic class	Weight in Kg
UST1	599	1000	3,6	T-600-S	0,26
UST1,5	936	1500	3,5	T-600-S	0,40
UST2	1134	2000	3,6	T-600-S	0,50

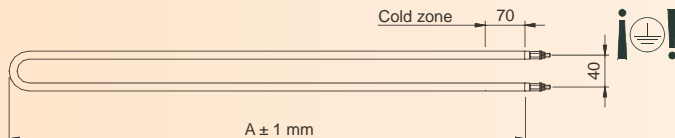

“M-4” Shape elements. M4ST Range

Code	Dimensions in mm		Watts	W/cm ²	Electricfor's constructive thermic class	Weight in Kg
	A	B				
M4ST1	259	329	1000	3,6	T-600-S	0,26
M4ST1,5	425	500	1500	3,5	T-600-S	0,40
M4ST2	527	598	2000	3,6	T-600-S	0,50

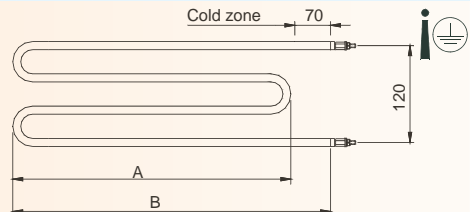

“M-6” Shape elements. M6ST Range

Code	Dimensions in mm		Watts	W/cm ²	Electricfor's constructive thermic class	Weight in Kg
	A	B				
M6ST1	169	239	1000	3,6	T-600-S	0,26
M6ST1,5	275	365	1500	3,5	T-600-S	0,40
M6ST2	348	416	2000	3,6	T-600-S	0,50

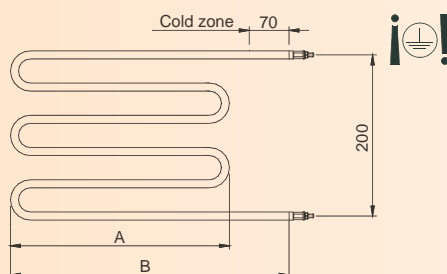

“M” Shape elements. M8ST Range

Code	Dimensions in mm		Watts	W/cm ²	Electricfor's constructive thermic class	Weight in Kg
	A	B				
M8ST1,5	205	288	1500	3,5	T-600-S	0,40
M8ST2	258	327	2000	3,6	T-600-S	0,50

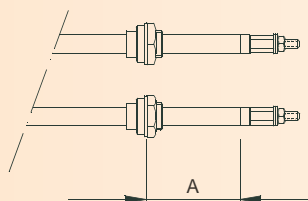
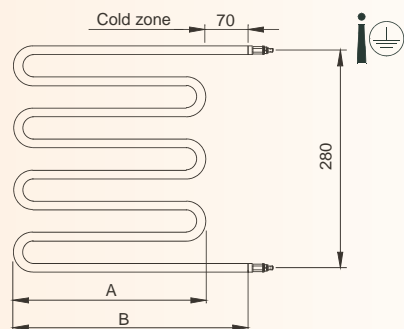

Option: Loose elements with M12x1'25 crimped connectors.

If you require, we can also supply you with the different types of heating elements with crimped connectors of M12x1'25 mm. When ordering, please specify the dimension A you require, noting that the maximum A = 40 mm

M12 Fast mounting connectors that anchor the element when the coupling presses on the foil. Each connector is supplied with a M12 nut and a washer.

Code	Description
102101011	M12x1,25 Quick fit connectors
128182000	Bags of 24 units





ELECTRIC BATTERIES WITH RECTANGULAR FIN HEATING ELEMENTS, ALBAT MODELS

General characteristics

- Galvanized Fe plate frame. Optionally, and to order, stainless steel chassis.
- Dismountable connection box.
- Shielded tubular heating elements in AISI 304 stainless steel of Ø8 mm, heating element insulated with electro-smelted magnesium oxide and compressed by lamination
- Aluminised plate fin 25 x 50 mm.
- Crimped M12 zinc steel connectors.
- Maximum application temperature: air output 100 °C with v_{air} = 2 m/sec
- Klixon thermostat included with 75°C protection. Optionally, with 120°C thermostat
- Possibility of connecting various modules.
- 1 or 2 power stages depending on models, both in single and three phase.
- Heating elements in single voltage ~230 V to enable different connection options.
- Standard voltage: 3~230 V Δ, 3~400 V Λ

To order, we can supply other dimensions, wattages or voltages, as well as different rectangular finned heating element options.

- Options:
 - All stainless steel.
 - For Ø8mm tube: fin 25 x 50 mm
fin 40 x 70 mm
 - For Ø10mm tube: fin 25 x 50 mm
fin 40 x 70 mm



Note: : The batteries are supplied without being wired, for you to carry out the electrical assembly according to your requirements

Normal applications

- To heat forced circulation air for heating premises, closed drying circuits in heaters, charge benches, etc. In general, for any application of forced air heating up to 100°C.

Standard models

Code	Dimensions in mm					Watts	Nº elements	Nº steps
	A	B	C	D	E			
ALBAT3	200	400	50	75	25	3000	3	1
ALBAT6	200	400	75	75	25	6000	6	2
ALBAT3-2	450	400	50	75	25	3000	3	1
ALBAT6-2	450	400	75	75	25	6000	6	2
ALBAT9	450	400	75	75	25	9000	9	3
ALBAT12	450	400	100	75	25	12000	12	4
ALBAT15	450	400	100	75	25	15000	15	5
ALBAT18	450	400	100	75	25	18000	18	6
ALBAT21	450	400	100	75	25	21000	21	7
ALBAT24	450	400	100	75	25	24000	24	8
ALBAT4,5	200	500	50	75	25	4500	3	1
ALBAT9-2	200	500	75	75	25	9000	6	2
ALBAT9-3	450	500	50	75	25	9000	6	2
ALBAT13,5	450	500	75	75	25	13500	9	3
ALBAT18-2	450	500	75	75	25	18000	12	4
ALBAT22,5	450	500	75	75	25	22500	15	5
ALBAT27	450	500	100	75	25	27000	18	6

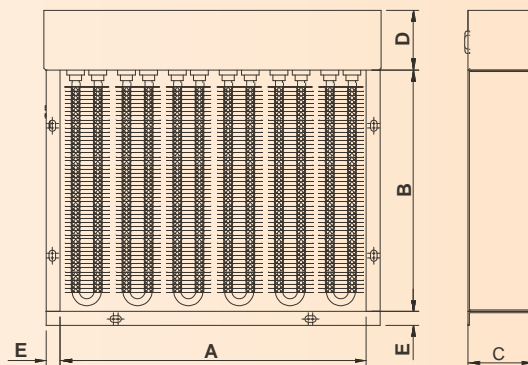

Front and back frames

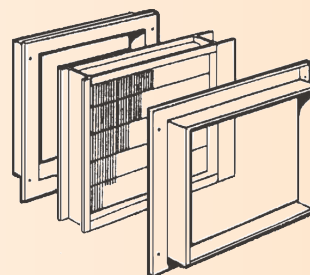

Battery-rack

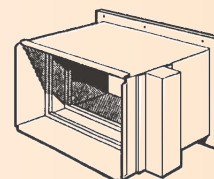

Fibre joint



Plate joint



Bayonet joint



Accessories for ALBAT battery standardised models

Code	Description
517541075	Thermostat klixon 75 °C. Free
1017000000	Thermostat klixon 75 °C. Mounted with tube and connector
EC10001	Set of framework for batteries ALBAT with dim A x B = 500 x 250 mm
EC10002	Set of framework for batteries ALBAT with dim A x B = 500 x 500 mm
EC10003	Set of framework for batteries ALBAT with dim A x B = 600 x 250 mm
EC10004	Set of framework for batteries ALBAT with dim A x B = 600 x 500 mm
EC10111	Battery holder for batteries ALBAT with dim A x B = 500 x 250 mm
EC10112	Battery holder for batteries ALBAT with dim A x B = 500 x 500 mm
EC10113	Battery holder for batteries ALBAT with dim A x B = 600 x 250 mm
EC10114	Battery holder for batteries ALBAT with dim A x B = 600 x 500 mm





ELECTRIC BATTERIES WITH SPIRAL FIN HEATING ELEMENTS, ALBAT MODELS

General characteristics

- Galvanized Fe plate frame. Optionally, and to order, stainless steel chassis.
- IP40 damp protection rating
- New system of connection box with flap opening without removing the lid.
- Shielded tubular heating elements in AISI 304 stainless steel of Ø10 mm, heating element insulated with electro-smelted magnesium oxide and compressed by lamination
- Stainless steel AISI 304 fin of Ø26mm outside diameter
- Crimped M14 zinc steel connectors.
- M4 or M6 threaded connector depending on models
- Application temperature: air output 60 °C
- Air passage speed recommended for 60°C: with $v_{air} = 3$ m/sec
- Klixon thermostat included with 85°C protection. Optionally, with 110°C thermostat
- Possibility of connecting various modules.
- 1 or 2 power stages depending on models, both in single and three phase.
- Heating elements in single voltage ~230 V to enable different connection options.
- Standard voltage: 3~230 V Δ , 3~400 V Δ

Detalle de la caja de conexiones abatible



To order, we can supply other dimensions, wattages or voltages, as well as different spiral finned heating element options.

- Options:
 - All stainless steel.
 - Spiral fin:
 - * For tube Ø8mm: stainless steel fin → Ø18, Ø24
iron fin → Ø23
 - * For Ø10mm tube: stainless steel fin → Ø20, Ø26, Ø30
iron fin → Ø25, Ø30

Normal applications

- To heat forced circulation air for heating premises, closed drying circuits in heaters, charge benches, etc. In general, for any application of forced air heating up to 200°C (Maximum temperature with $v_{air} = 4$ m/sec → 200°C).

Normal models

Code	Dimensions in mm					Watts	Nº elements	Shape	Nº steps
	A	B	C	D	E				
AHBAT3	330	260	70	92	15	3000	3	U	1
AHBAT6	330	475	70	92	15	6000	3	U	1
AHBAT9	330	700	70	92	15	9000	3	U	1
AHBAT12	550	475	160	92	15	12000	3	M4	1
AHBAT15	550	585	160	92	15	15000	3	M4	1
AHBAT18	550	700	160	92	15	18000	3	M4	1
AHBAT24	550	475	160	92	15	24000	6	M4	2
AHBAT30	550	585	160	92	15	30000	6	M4	2
AHBAT36	550	700	160	92	15	36000	6	M4	2

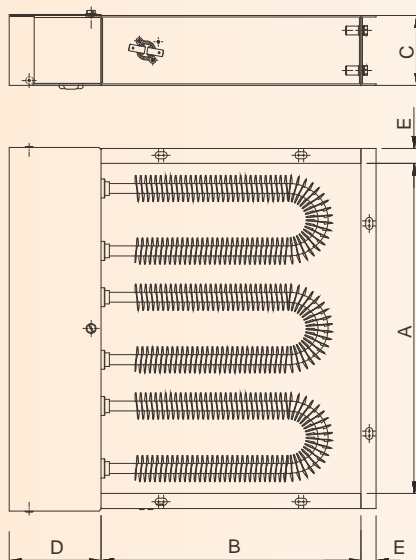

ELECTRIC BATTERIES FOR AIR CONDITIONING TYPE "R", BRP and BRG RANGES

General characteristics

- Chassis in gavanized steel. On order, chassis in stainless steel.
- Heating elements with exposed coil of quality 80-20 Nickel-Chrome, supported by steatite wall insulators.
- Maximum air discharge temperature of 60 °C
- Built-in thermostat of 60 °C. Optionally, with thermostat of 90 °C
- Standard voltage 3~230 V Δ, 3~400 V λ

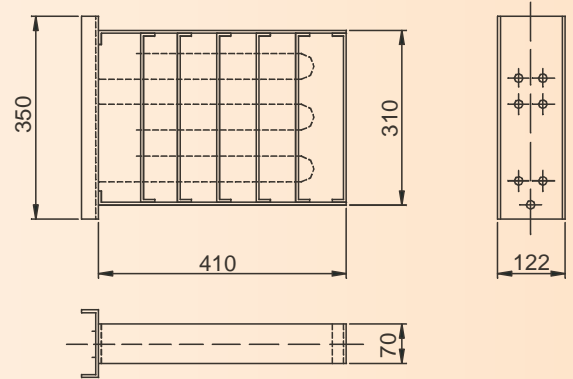
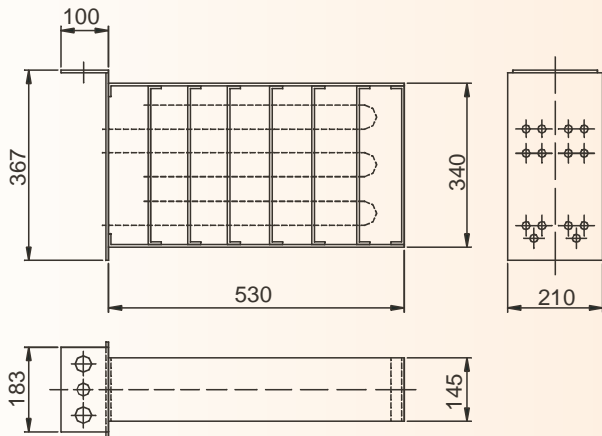
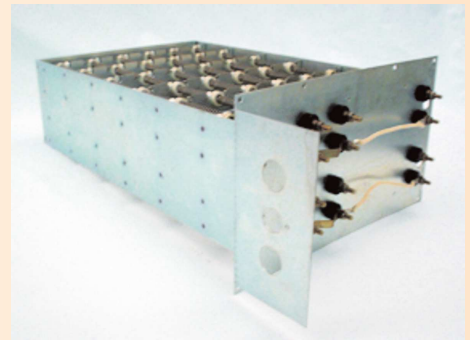

Code	Volts	Watts	Nº Stages	Weight in Kg
BRG15	3~230 Δ 3~400 λ	15000	2	
BRG20	3~230 Δ 3~400 λ	20000	2	
BRG25	3~230 Δ 3~400 λ	25000	2	
BRG30	3~230 Δ 3~400 λ	30000	2	

Code	Volts	Watts	Nº Stages	Weight in Kg
BRP5	3~230 Δ 3~400 λ	5000	2	
BRP10	3~230 Δ 3~400 λ	10000	2	
BRP15	3~230 Δ 3~400 λ	15000	2	

ELECTRIC BATTERIES FOR AIR CONDITIONING MINI SOPOR, BSMC and MNS RANGES

Small dimension batteries for window air conditioners or small ducts.

General characteristics

- Chassis in gavanized steel. On order, chassis in stainless steel.
- Heating elements with exposed coil of quality 80-20 Nickel-Chrome, supported by steatite wall insulators.
- Cable and earth connection of 500 mm long.
- They can work at minimum speeds of 2,5 m/sec.
- Built-in thermostat of 85 °C.
- Standard voltage ~230 V

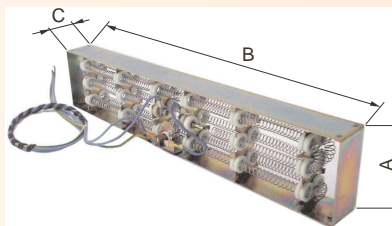

Code	Dimensions in mm			Volts	Watts	Weight in Kg
	A	B	C			
BSMC2	160	260	30	~230	2000	0,63
BSMC2,5	160	260	30	~230	2500	0,63
BSMC3	160	260	30	~230	3000	0,65
MNS2,3	88	415	40	~230	2300	0,70
MNS3,1	88	415	40	~230	3100	0,70
MNSMRC4	88	680	25	~230	4000	0,81
MNSMRL3	88	755	25	~230	3000	0,81

ELECTRIC BATTERIES FOR AIR CONDITIONING, ST RANGE

General characteristics

- Chassis in bichromatized steel. On order, chassis in stainless steel.
- Heating elements with exposed coil of quality 80-20 Nickel-Chrome, supported by steatite wall insulators.
- Connection cover with blind bottom.
- Built-in thermostat of 75 °C. Optionally, with thermostat of 92 °C
- Standard voltage 3~230 V Δ, 3~400 V λ

Code	Dimensions in mm				Volts	Watts	Nº Stages	Weight in Kg
	D	E	F	G				
ST6	350	40	340	420	3~230 Δ 3~400 λ	6000	1	
ST7,5	350	40	340	420	3~230 Δ 3~400 λ	7500	1	
ST9	350	40	340	420	3~230 Δ 3~400 λ	9000	1	
ST12	350	40	690	770	3~230 Δ 3~400 λ	12000	2	
ST15	350	40	690	770	3~230 Δ 3~400 λ	15000	2	
ST18	350	40	690	770	3~230 Δ 3~400 λ	18000	2	
ST24	350	40	690	770	3~230 Δ 3~400 λ	24000	2	
ST40	550	40	1300	1340	3~230 Δ 3~400 λ	40000	2	
ST401	800	40	1490	1570	3~230 Δ 3~400 λ	40000	3	

Code	Dimensions in mm					Volts	Watts	Nº Stages	Weight in Kg
	H	I	J	K	L				
ST241	1518	105	1400	480	450	3~230 Δ 3~400	24000	2	

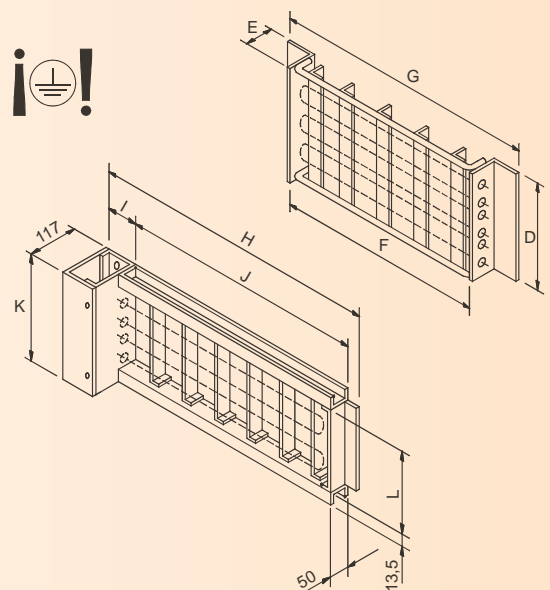

ELECTRIC BATTERIES FOR AIR CONDITIONING, MODUL-BAT RANGE

General characteristics

- Chassis in galvanized steel. On order, chassis in stainless steel.
- Tubular elements of stainless steel AISI 304L or AISI 321 Ø8 mm, insulated with electromelted and lamination-compressed magnesium oxide.
- Maximum air discharge temperature of 60 °C
- Built-in thermostat of 75 °C. Optionally, with thermostat of 110 °C
- From one to three modules may be coupled to provide from 4 to 30 kW. By combining these double or triple modules in a rack, a maximum of 120 kW may be attained.
- Standard voltage 3~230 V Δ, 3~400 V Δ

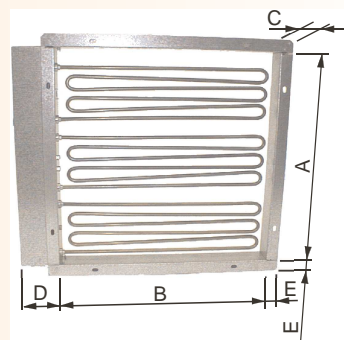

Code	Dimensions in mm					Watts	Nº Stages	Weight in Kg
	A	B	C	D	E			
MB4	450	450	50	82	25	4000	1	3,8
MB6	450	450	50	82	25	6000	1	3,8
MB8	450	450	50	82	25	8000	1	3,8
MB10	450	450	50	82	25	10000	1	4,3

ELECTRIC BATTERIES FOR AIR CONDITIONING, MODUL-SOPOR and MODUL-SOPOR REINFORCED RANGES

General characteristics

- Chassis, cover and dividers in galvanized steel. On order, chassis in stainless steel.
- Heating elements with exposed coil of quality 80-20 Nickel-Chrome, supported by steatite wall insulators.
- Maximum air discharge temperature of 60 °C.
- Built-in thermostat of 75 °C. Optionally, with thermostat of 110 °C.
- Standard voltage 3~230 V Δ, 3~400 V Δ

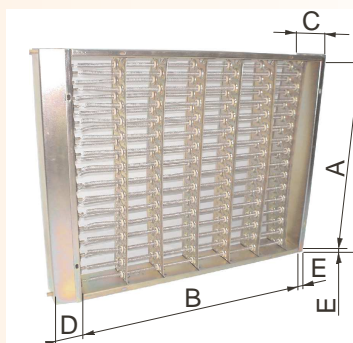

Models MODUL-SOPOR

Code	Dimensions in mm					Watts	Nº Stages	Weight in Kg
	A	B	C	D	E			
MSP4	330	330	70	46	12	4000	3	2,6
MSP5	330	330	70	46	12	5000	3	2,6
MSP6	330	330	70	46	12	6000	3	2,6
MSPR9	330	330	70	46	12	9000	4	2,6
MSPR12	330	330	70	46	12	12000	4	2,7
MSM8	330	610	70	46	12	8000	3	3,6
MSM10	330	610	70	46	12	10000	3	3,6
MSM12	330	610	70	46	12	12000	3	3,6
MSG10	445	610	70	46	12	10000	4	4,5
MSG14	445	610	70	46	12	14000	4	4,5
MSG16	445	610	70	46	12	16000	4	4,5
MSC9	456	620	70	46	10	9000	1	5,6
MSC12	456	620	70	46	10	12000	1	5,6
MSC15	456	620	70	46	10	15000	1	5,6
MSI21	456	870	70	46	10	21000	1	7,9
MSL31,5	456	1200	70	46	10	31500	2	10,8
MSL36	456	1200	70	46	10	36000	2	10,8
MSL45	456	1200	70	46	10	45000	2	10,8

Models MODUL-SOPOR REINFORCED

Code	Dimensions in mm					Watts	Nº Stages	Weight in Kg
	A	B	C	D	E			
MSRP3	164	350	70	46	12	3000	2	1,8
MSRP4,5	164	350	70	46	12	4500	2	1,8
MSRP6	164	350	70	46	12	6000	2	1,8
MSRM15	387	470	70	46	12	15000	5	4,2
MSRM17	387	470	70	46	12	17000	5	4,2
MSRM20	387	470	70	46	12	20000	5	4,2
MSRG32	536	800	70	46	12	32000	7	7,5
MSRG40	536	800	70	46	12	40000	7	7,5
MSRG48	536	800	70	46	12	48000	7	8,5
MSRI4	250	310	70	46	10	4000	1	2,2
MSRI6	250	310	70	46	10	6000	1	2,2
MSRI9	250	310	70	46	10	9000	1	2,2
MSRI12	250	310	70	46	10	12000	1	2,3
MSRL15	320	420	70	46	10	15000	1	3,3
MSRL18	320	420	70	46	10	18000	1	3,3
MSRL21	320	420	70	46	10	21000	1	3,3

ELECTRIC BATTERIES FOR AIR CONDITIONING, BACTI-SOPOR RANGE

General characteristics

- Chassis, cover and dividers in galvanized steel. On order, chassis in stainless steel.
- Arranged in a single row, the heating elements are with exposed coil of quality 80-20 Nickel-Chrome, supported by steatite wall insulators.
- Maximum air discharge temperature of 60 °C.
- Built-in thermostat of 75 °C. Optionally, with thermostat of 110 °C.
- Aside from the usual combinations of one behind the other, one beside the other, or horizontally joined, it is also possible to combine 1 or 2 BTSM modules with 1 or more BTSL modules to obtain assemblies of 1, 2, 3, 4 or 4 stages. Request the Technical Notice NTC-681.
- Standard voltage 3~230 V Δ, 3~400 V Δ

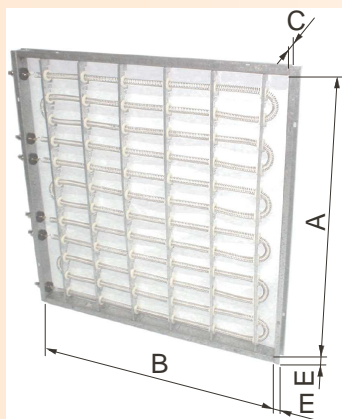

Code	Dimensions in mm				Watts	Nº Stages	Weight in Kg
	A	B	C	E			
BTSP2	228	478	27	11	2000	1	1,2
BTSP3	228	478	27	11	3000	1	1,2
BTSP4	228	478	27	11	4000	1	1,2
BTSP5	228	478	27	11	5000	1	1,2
BTSP6	228	478	27	11	6000	1	1,2
BTSM4	478	478	27	11	4000	1	1,6
BTSM6	478	478	27	11	6000	1	1,6
BTSM8	478	478	27	11	8000	1	1,6
BTSM10	478	478	27	11	10000	1	1,7
BTSM12	478	478	27	11	12000	1	1,8
BTSL2	228	678	27	11	2000	1	1,5
BTSL3	228	678	27	11	3000	1	1,5
BTSL4	228	678	27	11	4000	1	1,5
BTSL5	228	678	27	11	5000	1	1,5
BTSL6	228	678	27	11	6000	1	1,5
BTSL7,5	228	678	27	11	7500	1	1,6
BTSL9	228	678	27	11	9000	1	1,6



General characteristics

- Class I electrical heater
- Steel painted connections box with degree protection against moisture IP44
- Cylindrical pipe galvanised steel sheet. On order, in stainless steel
- PG for power supply and control cables.
- From 1 to 6 tubular elements in stainless steel tube AISI 321 or AISI 304L of \varnothing 6.4 mm for the single-phase models and \varnothing 8 mm for the three-phase models.
- Built-in safety thermostat of 85°C. On order we can supply a safety thermostat of 110°C.
- 1 or 2 power stages according to models, in both single-phase and three-phase groups.
- Heating elements in unitary voltage ~230V in order to make the different connection options easier.
- High resistance to impacts and splashes of water.



Mono-phase models. BMC

Code	Watts		Dimensions in mm					Weight in Kg
	Min.	Max.	$\varnothing A$	B	C	D	E	
BMC80-0,5		500	80	200	49	105	105	0,70
BMC100-0,5		500	100	200	49	105	105	0,82
BMC100-0,8		800	100	200	49	105	105	0,82
BMC125-0,75		750	125	250	49	105	105	0,97
BM2C125-1	500	1000	125	300	83	206	156	1,8
BM2C160-1,2	600	1200	160	300	83	206	156	2,1
BMC200-1,7		1700	200	250	49	105	105	1,4
BM2C200-2,25	1125	2250	200	300	83	206	156	2,4

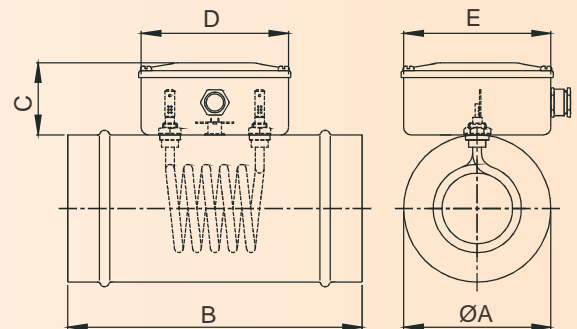

- Standard voltage: ~230 V

Three-phase models. BTT

Set of battery of heating elements + "T" of nominal \varnothing

Code	Watts		Nº elements	Dimensions in mm				Weight in Kg
	Min.	Max.		$\varnothing A$	B	C	D	
BTT160-1,5	250	1500	6	160	340	260	160	3,5
BTT200-3	500	3000	6	200	390	300	200	5,1
BTT250-4,5	750	4500	6	250	440	350	250	6,1
BTT315-6	2000	6000	3	315	490	415	315	6,7
BTT315-9	1500	9000	6	315	490	415	315	7,6
BTT355-9	1500	9000	6	355	490	455	355	7,9
BTT355-12	4000	12000	3	355	490	455	355	8,2
BTT400-15	2500	15000	6	400	600	500	315	9,8

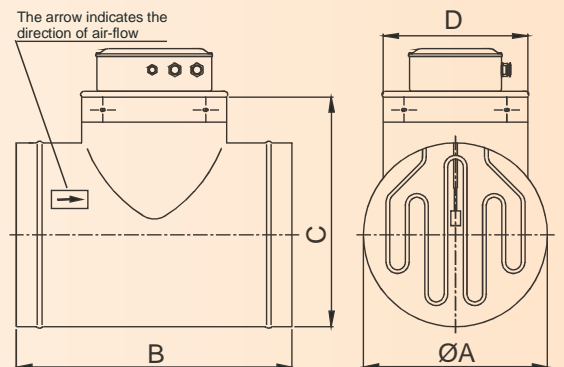

- Standard voltage 3~230 V Δ , 3~400 V Λ
- By a simple change in the connection box, we can obtain a wide range of power in each model, from the minimum to a maximum indicated

Spare parts for the three-phase models BTT

Batteries without "T"

Code	Watts		Nº elements	For $\varnothing A$ in mm
	Maximum	Minimum		
BTCC1,5	1500	250	6	160
BTCC3	3000	500	6	200
BTCC4,5	4500	450	6	250
BTCC6	6000	2000	3	315
BTCC9	9000	1500	6	315
BTCC9A	9000	1500	6	355
BTCC12	12000	4000	3	355
BTCC15	15000	2500	6	400

Unit elements

Code	Watts	W/cm ²	For $\varnothing A$ in mm	Electricfor's constructive thermic class
130540003	250	3	160	T-600-S
130540002	500	3	200	T-600-S
130540001	750	3	250	T-600-S
130540004	2000	3	315	T-600-S
130540000	1500	4	315 355	T-600-S
130540005	4000	4	355	T-600-S
130540006	2500	5	400	T-600-S

"T" of nominal \varnothing

Code	$\varnothing A$ in mm
130540104	160
130540103	200
130540102	250
130540101	315
130540100	355
130540105	400

General characteristics

- Heating of air to:

250 °C

TFAN models

600 °C

Made to order

NOTE: The above temperatures refer to recirculated air systems with thermal insulation. Note that the final heating temperature may vary in accordance with the system's operating conditions (recirculation of air or not, the material being heated, losses of heat, etc). Our technical department is at your service to assist in the selection of the most appropriate battery for any given situation.

- Minimum air speed for all models: **2 m/sec**
- Easily interchangeable heating elements
- Other wattage, voltages, and dimensions are available on request.
- Manufactured in compliance with the EN 60335-1 standard.
- Triphase power supply 3 ~ 400 V Δ with earth connection (*).

(*): The TFAN batteries are supplied connected at the stated voltage. Optionally, they may be supplied connected for an operating voltage of 3 ~ 230 V Δ . If this is required, please state so in your order.

Technical characteristics of construction

- 1 From one to three stuffing boxes per heat stage, plus a stuffing box for control components.
- 2 Steel connection cover, with oven treated paint resistant to temperatures of up to 250 °C without deterioration.
- 3 From one to three steatite connection boards, one per stage. Nickel-plated internal connection bridges.
- 4 Bases for securing heating elements with tightening screws.
- 5 Mineral fibre insulation (in base box and drawer).
- 6 Steel base box for heating elements, with oven treated paint resistant to temperatures of up to 250 °C without deterioration, and stainless steel inner box.
- 7 Stainless steel bars for securing final guide base and tightening of cover.
- 8 Stainless steel final guide for supporting the heating elements.
- 9 Tubular elements in Ø10 mm AISI 321 or 304L. stainless steel tube, in alignments of 6 heating elements at ~230 V with wattage of 1000 W
- 10 Thermocouple probe Ø 6 Ni Cr / Ni Al (K type) with 3000 mm long compensating cables.

Option all in stainless steel: If you require, we can supply the TFAN models with connection cover (2), big box and base box for heating elements (5) all in stainless steel.

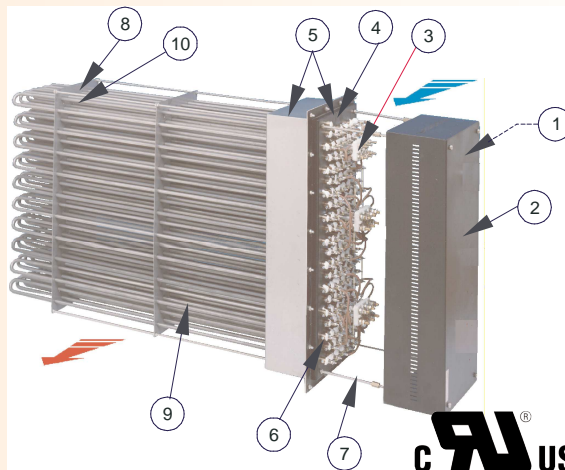

MODELS TFAN

Models available with elements in stainless steel tube AISI 321 Ø10 mm

Code	Power kW	Nº elements	Nº stages	Dimensions in mm				Weight in Kg
				A	B	C	L	
TFAN6	6	6	1 de 6 KW	90	118	162	440	6,3
TFAN12	12	12	1 de 12 KW	150	178	222	440	9,8
TFAN18	18	18	1 de 6 KW 1 de 12 KW	210	238	282	440	13,2
TFAN24	24	24	2 de 12 KW	270	296	343	440	16,7
TFAN30	30	30	1 de 6 KW 2 de 12 KW	330	352	404	440	20,1
TFAN36	36	36	3 de 12 KW	390	416	464	440	23,6
TFAN42	42	42	2 de 12 KW 1 de 18 KW	450	472	524	440	27,0
TFAN48	48	48	1 de 12 KW 2 de 18 KW	510	532	584	440	30,5
TFAN54	54	54	1 de 12 KW 1 de 18 KW 1 de 24 KW	570	592	644	440	33,9
TFAN60	60	60	1 de 12 KW 2 de 24 KW	630	652	704	440	37,4

DIMENSIONS

MODELS TFAN

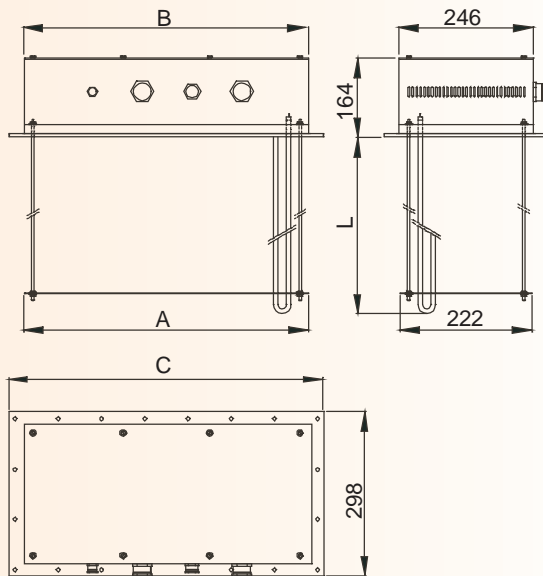

Note: Batteries TFAN incorporate a thermocouple type "K" with aerial male connector and female bayonet. Although for some applications they aren't necessary, Electricfor recommends to install always minimum a sobretemperature sensor (sensor-regulator) and a flow switch.

Sensor temperature type "K" for TFAN batteries

Code	Description	Dimensions in mm
517380000	Type "K" sensor with aerial male connector and female bayonet connector	Ø6 x 475



General characteristics

- Heating of air to:

450 °C

TMAX and TMAXL models

600 °C

Made to order

NOTE: The above temperatures refer to recirculated air systems with thermal insulation. Note that the final heating temperature may vary in accordance with the system's operating conditions (recirculation of air or not, the material being heated, losses of heat, etc). Our technical department is at your service to assist in the selection of the most appropriate battery for any given situation.

- Minimum air speed for all models: **2 m/sec**
- Easily interchangeable heating elements
- Other wattage, voltages, and dimensions are available on request.
- Manufactured in compliance with the EN 60335-1 standard.
- Triphase power supply 3 ~ 400 V Δ with earth connection (*).

(* The TMAX and TMAXL batteries are supplied connected at the stated voltage. Optionally, they may be supplied connected for an operating voltage of 3 ~ 230 V Δ . If this is required, please state so in your order.

Technical characteristics of construction

- From one to three stuffing boxes per heat stage, plus a stuffing box for control components.
- Steel connection cover, with oven treated paint resistant to temperatures of up to 250 °C without deterioration.
- From one to three steatite connection boards, one per stage. Nickel-plated internal connection bridges.
- Bases for securing heating elements with tightening screws.
- Mineral fibre insulation (in base box and drawer).
- Steel base box for heating elements, with oven treated paint resistant to temperatures of up to 250 °C without deterioration, and stainless steel inner box.
- Stainless steel bars for securing final guide base and tightening of cover.
- Stainless steel final guide for supporting the heating elements. In TMAXL models additional middle support.
- Tubular elements in $\varnothing 10$ mm AISI 321 or 304L. stainless steel tube, in alignments of 6 heating elements at ~230 V with wattage 750 W (TMAX models) or 1500 W (TMAXL models) each. In stock for TMAX and TMAXL models with $\varnothing 10$ mm Incoloy®-800 stainless steel heating elements.
- Optional: thermocouple probe $\varnothing 6$ Ni Cr / Ni Al (K type) with 3000 mm long compensating cables.

Option all in stainless steel: If you require, we can supply the TMAX and TMAXL models with connection cover (2), big box and base box for heating elements (5) all in stainless steel.

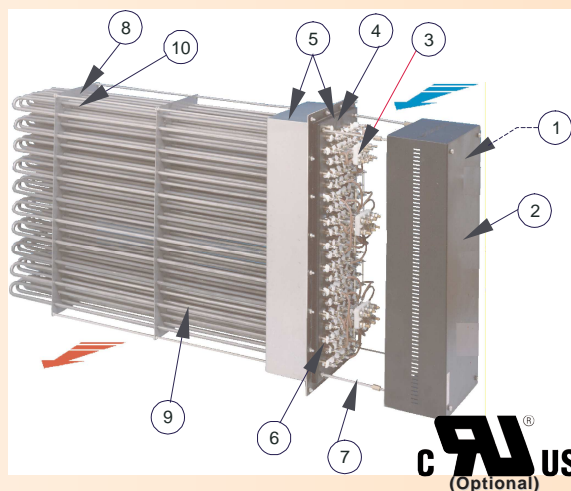

DIMENSIONS

MODELS TMAX and TMAXL

MODELS TMAX	Code	Power kW	Nº elements	Nº stages	Dimensions in mm				Weight in Kg
					A	B	C	L	
Models available with elements in stainless steel tube AISI 321 $\varnothing 10$ mm or Incoloy®-800 $\varnothing 10$ mm	TMAX9	9	12	1 de 9 KW	172	172	222	542	12,4
	TMAX13,5	13,5	18	1 de 4,5 KW 1 de 9 KW	232	232	282	542	16,4
	TMAX18	18	24	2 de 9 KW	292	292	343	542	20,4
	TMAX22,5	22,5	30	1 de 4,5 KW 2 de 9 KW	352	352	404	542	24,3
	TMAX27	27	36	3 de 9 KW	412	412	464	542	28,3
	TMAX31,5	31,5	42	2 de 9 KW 1 de 13,5 KW	472	472	524	542	32,3
	TMAX36	36	48	1 de 9 KW 2 de 13,5 KW	532	532	584	542	36,3
	TMAX40,5	40,5	54	1 de 9 KW 1 de 13,5 KW 1 de 18 KW	592	592	644	542	40,2
	TMAX45	45	60	1 de 9 KW 2 de 18 KW	652	652	704	542	44,2
MODELS TMAXL	Code	Power kW	Nº elements	Nº stages	Dimensions in mm				Weight in Kg
Models available with elements in stainless steel tube AISI 321 $\varnothing 10$ mm or Incoloy®-800 $\varnothing 10$ mm					A	B	C	L	
	TMAXL18	18	12	1 de 18 KW	172	172	222	962	16,7
	TMAXL27	27	18	1 de 9 KW 1 de 18 KW	232	232	282	962	22,8
	TMAXL36	36	24	2 de 18 KW	292	292	343	962	28,9
	TMAXL45	45	30	1 de 9 KW 2 de 18 KW	352	352	404	962	35,0
	TMAXL54	54	36	3 de 18 KW	412	412	464	962	41,1
	TMAXL63	63	42	2 de 18 KW 1 de 27 KW	472	472	524	962	47,2
	TMAXL72	72	48	1 de 18 KW 2 de 27 KW	532	532	584	962	53,3
	TMAXL81	81	54	1 de 18 KW 1 de 27 KW 1 de 36 KW	592	592	644	962	59,4
	TMAXL90	90	60	1 de 18 KW 2 de 36 KW	652	652	704	962	65,5

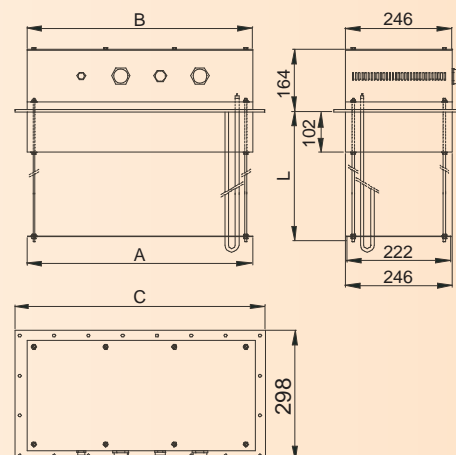

Note: Batteries TMAX and TMAXL incorporates a thermocouple type "K" with aerial male connector and female bayonet. Although for some applications they aren't necessary, Electricfor recommends to install always minimum a sobretemperature sensor (sensor-regulator) and a flow switch.

Sensor temperature type "K" for TMAX and TMAXL

Code	Desacription	Dimensions in mm
517381000	Type "K" sensor with aerial male connector and female bayonet connector. For TMAX models	$\varnothing 6$ x 575
517382000	Type "K" sensor with aerial male connector and female bayonet connector. For TMAXL models	$\varnothing 6$ x 975



UTFAN / UTMAX / TMAXL

Models as per catalogue: NTC - 0112

GROUP 2 - Heating elements for air

2.11 - Heating elements for ovens and furnaces

General characteristics

- Heating of air to:
 - 250 °C UTFAN models
 - 450 °C UTMAX and UTMAXL models
 - 600 °C UTMAXIN and UTMAXLIN models
- Minimum air speed for all models: 2 m/sec

- Tubular elements in stainless steel tube AISI 321 or 304L of Ø10 mm. In stock for the TMAX and TMAXL models, tubular elements in Incoloy®-800 of Ø10 mm
- Standard voltage ~230 V
- Option: Stainless steel crimped connector of M14x1,25 mm

Option WITHOUT crimped connectors

Code	Dimensions in mm			Watts	W/cm²	Tube material	Electricfor's constructive thermic class	Weight in Kg
	C	D	L					
UTFAN1	93	420	513	1000	3,9	AISI 321	T-700-T	0,45
UTMAX0,75	187	420	607	750	3,1	AISI 321	T-700-T	0,53
UTMAXL1,5	187	840	1027	1500	3	AISI 321	T-700-T	0,90
UTMAXIN0,75	187	420	607	750	3,1	Iy@-800	T-850-T	0,53
UTMAXLIN1,5	187	840	1027	1500	3	Iy@-800	T-850-T	0,90

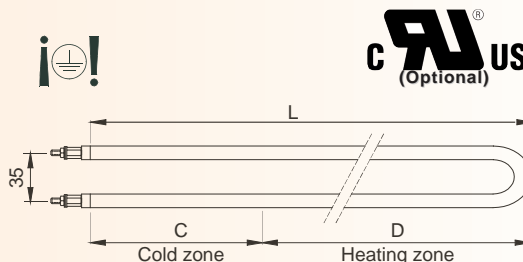

Option WITH stainless steel crimped connectors of M14x1,25

Code	Dimensions in mm					Watts	W/cm²	Tube material	Electricfor's constructive thermic class	Weight in Kg
	A (*)	B	C	D	L					
UTFAN1RI	73	440	93	420	513	1000	3,9	AISI 321	T-700-T	0,50
UTMAX0,75RI	167	440	187	420	607	750	3,1	AISI 321	T-700-T	0,58
UTMAXL1,5RI	167	860	187	840	1027	1500	3	AISI 321	T-700-T	0,95
UTMAXIN0,75RI	167	440	187	420	607	750	3,1	Iy@-800	T-850-T	0,58
UTMAXLIN1,5RI	167	860	187	840	1027	1500	3	Iy@-800	T-850-T	0,95

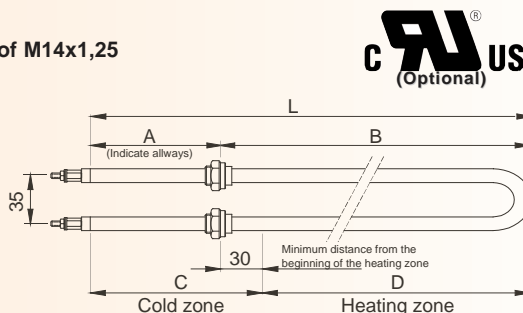

(*) Dimension A according to your order. You must indicate it in all the orders of this material. The maximum value of the dimension A is the value indicate in the table.

M8GRK

GROUP 2 - Heating elements for air

2.12 - Heating elements for ovens and furnaces

General characteristics

- Tubular elements in stainless steel tube AISI 321 or 304L of Ø10 mm, insulated with electromelted and lamination-compressed magnesium oxide
- Terminals BM4-P (Thread M4)
- Zinc-plated steel crimped connectors, thread M14x1'25 mm
- Standard voltage ~230 V

Applications

- Air conditioning
- Recirculated air heaters
- Static air heaters
- Black heat
- Textile industrial heating
- Trichloroethylene vapor reheating
- Shrink plastic ovens
- Ovens in general
- Dryers
- Air heaters
- Hot air convectors
- Chemical reactors

Code	Dimensions in mm				Length of element	Watts	W/cm²	Electricfor's constructive thermic class	Weight in Kg
	A	B	C	D					
M8GRK1	250	236	100	170	291	1000	1,8	T-700-T	0,75
M8GRK1,5	251	237	100	175	292	1500	2,6	T-700-T	0,75

Dimensions of the M14x1'25 crimped connector

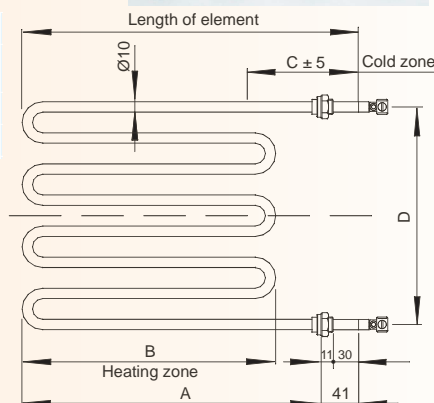
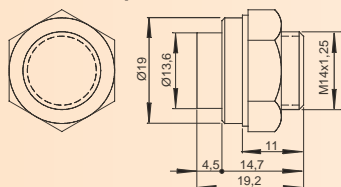

Relationship between the maximum atmospheric temperature of the furnace or oven in the heating element area (where a safety sensor should be installed) and the load of the heating elements in W/cm².

Consult our temperature regulator: pages 116, 117, 118 and 119 of this catalogue.

W/cm²	Air at rest	Recirculated air at 1 m/sec. In heating element area	Recirculated air at 2 m/sec. In heating element area	Recirculated air at 3 m/sec. In heating element area	Recirculated air at 4 m/sec. In heating element area
1,8	450 °C.	500 °C	530 °C	560 °C	580 °C
2,5 to 3,1	350 °C.	380 °C	430 °C	470 °C	500 °C
4,1 to 4,7	Amb. Temp max. 80 °C.	175 °C	275 °C	340 °C	400 °C

Maximum ambiental temperature in heating element area

IMPORTANT NOTE: The atmospheric temperature inside the furnace or oven chamber will always be 25-350°C lower than in the heater element area depending on good air circulation, loads of material and frequency of loads.





General characteristics

- Tubular elements in stainless steel tube AISI 321 or 304L of Ø8 mm, insulated with electromelted and lamination-compressed magnesium oxide

- Terminals BM4-P (Thread M4)
- Zinc-plated steel crimped connectors, thread M14x1'25 mm
- Standard voltage ~230 V

Usual applications

- Air conditioning
- Recirculated air heaters
- Static air heaters
- Black heat

- Textile industrial heating
- Trichloroethylene vapor reheating
- Shrink plastic ovens
- Ovens in general
- Dryers
- Air heaters
- Hot air convectors
- Chemical reactors

Dimensions of the M12x1'25 crimped connector

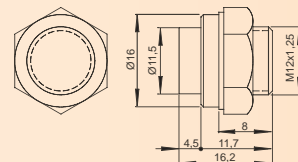

Models REINF

Code	Dimensions in mm		Watts	W/cm ²	Electricfor's constructive thermic class	Weight in Kg
	C	L				
REINF460	50	460	500	5,7	T-700-T	0,10
REINF960	50	960	1000	4,7	T-700-T	0,20

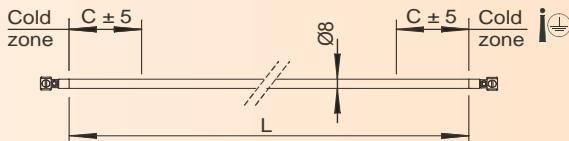

Models R

Code	Dimensions in mm			Watts	W/cm ²	Electricfor's constructive thermic class	Weight in Kg
	A	C	L				
R762	738	45	762	500	3	T-700-T	0,20
R1092	1068	45	1092	750	3,1	T-700-T	0,26
R1422	1398	45	1422	1000	3,1	T-700-T	0,34
R2092	2068	45	2092	1500	3	T-700-T	0,49

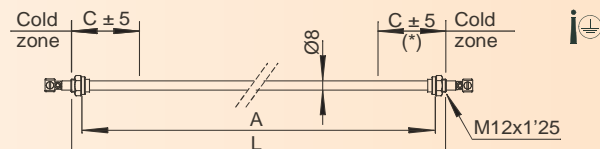

(*) The connector of one of the ends is installed without being attached

Models U

Code	Dimensions in mm			Watts	W/cm ²	Electricfor's constructive thermic class	Weight in Kg
	A	C	L				
U365	365	45	377	500	3	T-700-T	0,20
U530	530	45	542	750	3,1	T-700-T	0,26
U695	695	45	707	1000	3,1	T-700-T	0,34
U1030	1030	45	1042	1500	3,1	T-700-T	0,49
U1365	1365	45	1377	2000	3,1	T-700-T	0,58

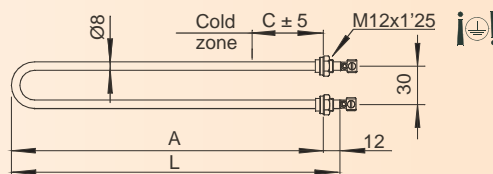

Models Mx360

Code	Dimensions in mm					Watts	W/cm ²	Electricfor's constructive thermic class	Weight in Kg
	A	B	C	D	L				
M4360	360	330	45	90	372	1000	3,1	T-700-T	0,34
M6360	360	330	45	150	372	1500	3,1	T-700-T	0,49
M8360	360	330	45	210	372	2000	3,1	T-700-T	0,58
M12360	360	330	45	330	372	3000	3	T-700-T	0,89

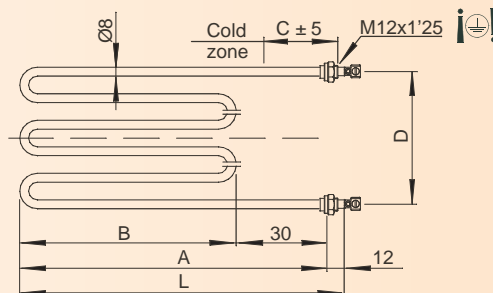

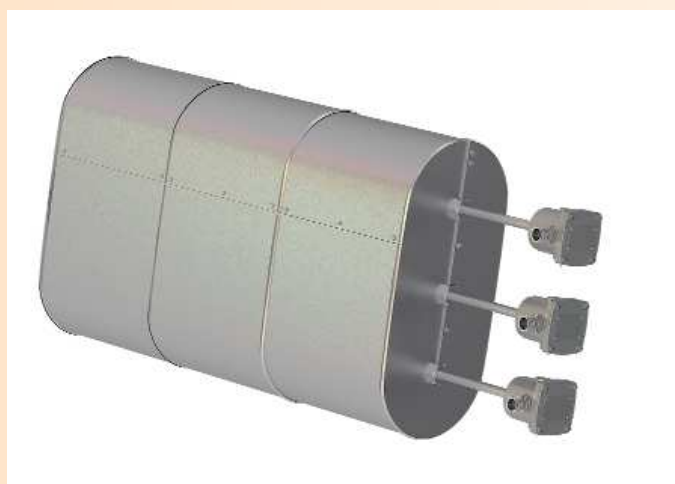

Maximise your heating applications with Boron Nitrid Heaters!

The world is changing, and the industry of the 21st century faces new challenges!

- Productivity
- Energy saving & environment protection
- Cost reduction

Same power,
but different sizes and
heating properties!

Magnesia
heaters

Boron Nitrid
heaters

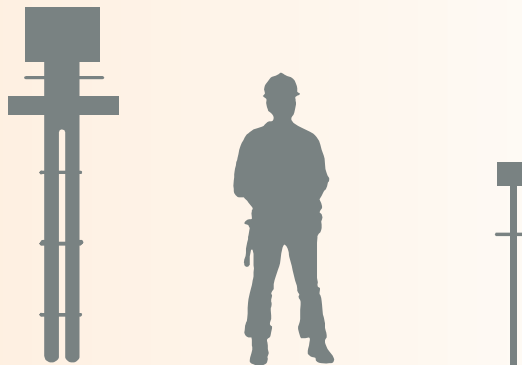

Main advantages of Boron Nitrid technology

- Temperature gradient improved by 10 compared to Magnesia
- Heating 100% homogeneous (Straight wire)
- Ring-shaped flow improves heat transfer up to 100 W/cm² and more
- Available in ATEX/IECEX
- Medium voltage
- No leakage current at high temperature
- Specific tube sheath to increase heat transfer coefficient and heat surface
- Reduced heater weight

Key technical features

- Customized product
- Wire Ni-Cr 80/20
- W/cm² : 10 à 200 W/cm²
- Voltage: 24 V /48 V (DC), usually 110 to 750 V AC/DC, max medium voltage
- Operational temperature: from -270 °C to +1000 °C
- Pressure: superior to 300 bars

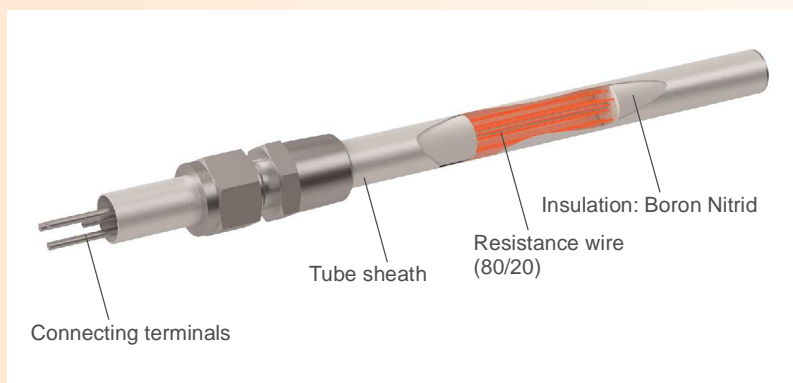

Customers references

- ALSTHOM
- YOTAL / IFP
- FORCE BOLOGNE
- SNECMA
- STEIN
- POWER HOUSE TOOLS
- SEICO
- DCNS
- ZETON
- LIEBHERR AEROSPACE
- CEA
- EDF
- TORAY
- CEAT

Industrial sectors

The Boron Nitrid Heaters are interesting for all industrial sectors looking for higher productivity, saving space or working with high temperature process.

Examples:

- Shipyard
- Oil & Gas / offshore platform
- Chemical industry
- Power industry
- Nuclear industry
- Packaging
- Thermoforming
- Submarine
- Aeronautics
- Aerospace



Benefits and Processes

Smaller equipment



- Complete system cost reduction (especially when vessel with high pressure (DESP), insulation)
- Space saving and easier to handle
- Weight saving
- Temperature loss reduction (surface minimized)
- Easier handling for installation
- Inertia reduced, better temperature control accuracy

Increased productivity



- More heat in less time for shorter production cycles

Bolt Heater

Bring a lot of heat in the drilled bolt to reduce the maintenance cycle time (tightening and untightening of the nut.)



High temperature

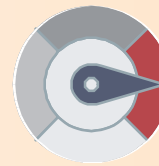

- High temperature process, up to 1000°C
- Temperature gradient improved by 10 compared to Magnesita

Liquid heating

Improved heat transfer (up to 100W/cm²) thanks to ring-shaped vessel to reduce the size of the heating system: corrosive, polluting or thermal fluid heating / high power pressure system / high power system / Steam super heater



Braking resistors

Circulation heater for offshore platforms

Flange immersion heater

Reduce the size of highpower flange immersion heater while ensuring good heat transfer Tank heating

Matrix Heating

Bring a lot of heat in the matrix to reduce the cycle time in comparison to usual cartridges

Mold Heating

Bring a lot of heat in the mold for specific thermoforming process (Aeronautics, Automobile) to reduce the process cycle time

Ignition point

Ignition of inflammable gas using small equipment

Boron Nitrid heaters

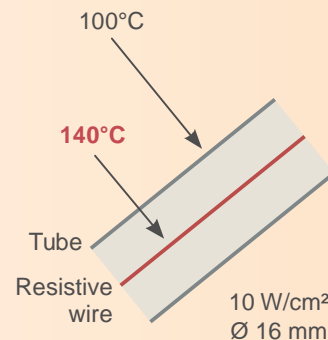

Magnesia heaters

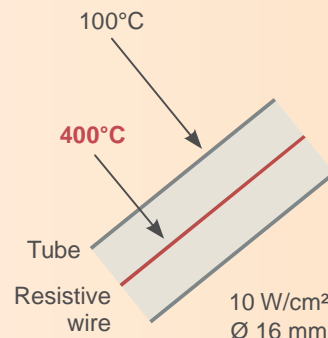

Gas heating

Heat process requiring high temperature such as bench tests with high air flow (aeronautics ...) / chemical processes (Polymerization)

Project examples

Steam superheater in ex-proof area

Customer: DCNS



- Power: 42 Kw
- Voltage: 360 Vcc
- Fluid: Capor saturado a 54 bara
- Flowl: 70 Kg/h - 140 Kg/h
- Outlet temperature: +515 °C
- Construction: 316 Ti vessel with 4 heating rod THP 10,5 Kw, 4 safety sensor for heaters, 2 for vessel, and 1 on outlet. The whole is assembled in 304 SS cabinet with controlled pressurisation 3 – 10 mbar, EExpz 2C T3 approved
- Purpose of use: Test bench

Hot oil Heating Cooling Unit 400 °C

Cliente: AIRBUS INDUSTRIE



- Power: 600 Kw
- Voltage: 3~400 V, 50 Hz
- Fluid: Therminol VP1
- Pump: Magnetic drive pump 80 m³/h
- Heater: 17 boron nitrid heating rods 35,5 Kw
- Cooler: Twisted tube exchanger 600 Kw
- Accessories: Flow controller, expansion tank, emptying drum, 3 grate and isolation valves
- Cabinet: 100 % SCR power control by PLC
- Purpose of use: PEEK press moulding

Heating elements

Electricfor, S.A. manufactures and imports all kinds of heating elements for industrial ovens and laboratory furnaces.

Spiral or curved heating elements for ovens

Heating elements with Kanthal A1, Kanthal AF and Kanthal APM alloy threads are highly resistant and known for their capacity to withstand high load densities. They can be used up to maximum element temperatures of 1425 °C.

NiCr alloys are characterised for their excellent properties when hot and very good properties against rusting and corrosion. They can be used up to maximum element temperatures of 1250 °C.

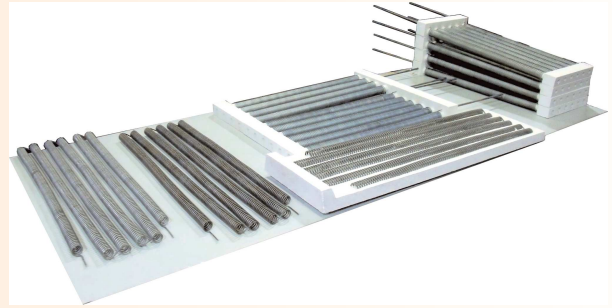

Metallic heating element system for radiant tubes

We manufacture the complete system of heating element, rods and ceramic parts that make up this kind of element.

This kind of heating element enables the use of high loads using large threads. Maximum furnace temperatures of up to 1050 °C.



Heating panels

These are coiled thread heating elements partially embedded in refractory concrete that together form a self-supporting heating module.

These elements can be used for oven temperatures of up to 1100 °C.

Frequently used in the non-ferrous metal welding industry.

They can be manufactured in different shapes according to specific requirements, including manufacturing of complete muffle furnaces.

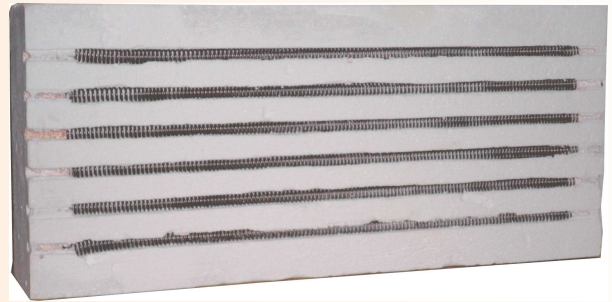

Combined systems

Made up of the combination of corrugated thread heating elements and special fibres so the heating elements are hung directly on the fibre through a system of hooks, which enables fast manufacturing or re-modelling of furnaces, even for non-expert staff.

The maximum working temperature for these systems is 1200 °C.

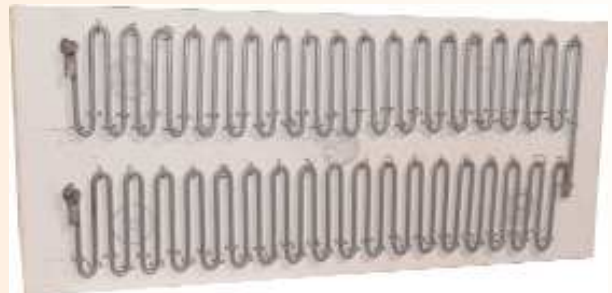

Silicon carbide ceramic heating elements

Silicon carbide ceramic heating elements are manufactured from recrystallized highly pure silicon carbide sand.

They are used in electric ovens in the ceramics, glass, chemical, metalworking and electronics industries. They can work at temperatures of up to 1625°C.

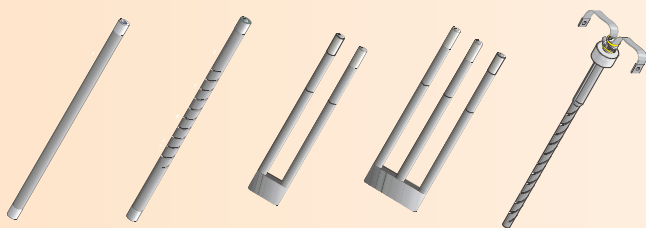

Molybdenum disilicide ceramic heating elements

Molybdenum disilicide electric heating elements are made up of ceramic and metal material that can operate at high temperatures with an excellent coefficient of performance.

The maximum working temperature for these elements is up to 1800 °C.

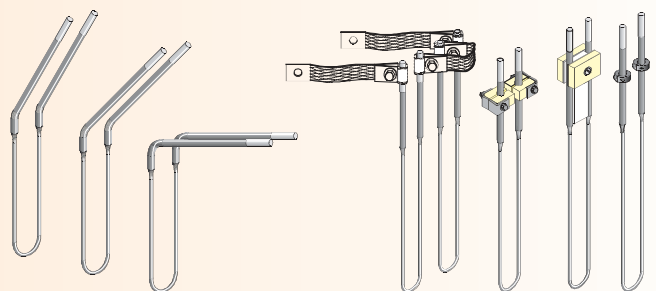

Braking heating elements work through dissipation of the energy generated by the electrical machine inside them or in braking units

SAC/PR Models

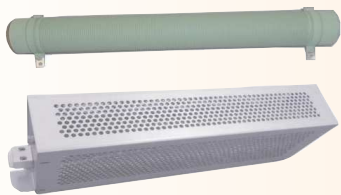

General characteristics

- SAC/PR model heating elements are designed for braking engines.
- They can be supplied with thermal protector.
- Ohmic value according to the client's request
- The heating element tolerance can also be supplied according to the client's specification.
- The manufacturing system enables adapting to the client's needs, both as far as specifications as well as in delivery terms (72 hours) and amounts.

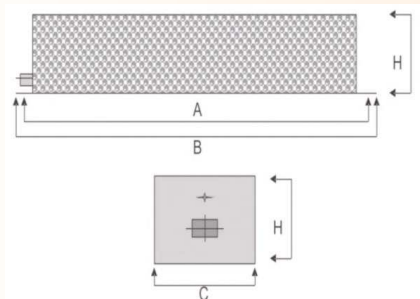

Code	Dimensions in mm				Watts
	A	B	C	H	
SAC/PR-600	405	420	55	98	600
SAC/PR-1000	412	430	70	116	1000
SAC/PR-1200	412	430	80	135	1200
SAC/PR-1500	490	512	80	135	1500
SAC/PR-2500	490	512	80	135	2500
SAC/PR-4000	490	510	174	143	4000
SAC/PR-4500	490	510	174	143	4500
SAC/PR-6000	490	510	350	140	6000
SAC/PR-10000	490	510	538	140	10000
SAC/PR-14000	490	510	696	140	14000

SI/PR Models



General characteristics

- SI/PR model heating elements are specially designed as braking loads for engines without reducer, minimising the noise level (gearless).
- They can be supplied with thermal protector.
- Ohmic value according to the client's request
- The heating element tolerance can also be supplied according to the client's specification.
- The manufacturing system enables adapting to the client's needs, both as far as specifications as well as in delivery terms (72 hours) and amounts.

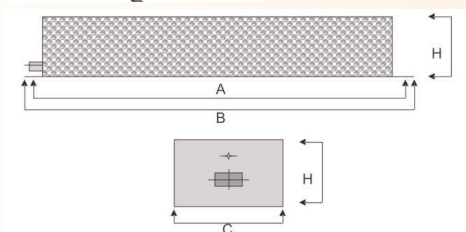

Code	Dimensions in mm				Watts
	A	B	C	H	
SI/PR-600	412	430	80	135	600
SI/PR-1000	412	430	80	135	1000
SI/PR-1500	412	430	80	135	1500
SI/PR-2400	412	430	80	135	2400
SI/PR-4800	412	430	180	140	4800
SI/PR-6000	412	430	265	140	6000
SI/PR-8000	412	430	350	140	8000
SI/PR-10000	412	430	535	140	10000
SI/PR-14000	412	430	696	140	14000

RB/PL Model

General characteristics

- The RB/PL flat armoured heating element model is designed for frequency converters (braking)
- Tolerance of ± 10%

Code	Watts
RB/PL-600	600
RB/PL-1300	1300 – With dissipater

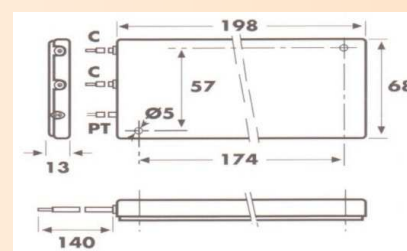

RB Model

General characteristics

- The RB flat armoured boxed heating element model is designed for frequency converters (braking)
- Tolerance of ± 10%

Code	Watts
RB-250	250

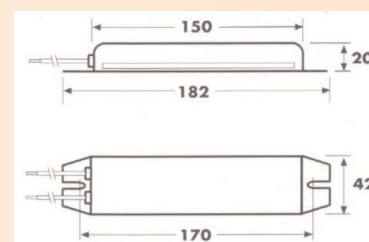

General features

- Reinforced tubular elements in annealed stainless steel AISI 304 or AISI 321, Ø8mm, insulated heating element with electrofused magnesium oxide and compressed by flat-rolling.
- Terminal M4. Direct screw on heating element output.
- Each element comes with 6 M4 nuts and 8 washers for connection.
- Standard voltage ~230 V

Usual applications

- Working in air.** Up to 100 °C in still air atmospheric temperature. For higher working temperatures forced air is recommended. Please consult our Technical Department in the event of queries.
- Working in immersion.** The connection terminals must first be made water-tight. Can be used in water with low chlorine content (natural water). Also for neutral and alkaline aqueous solutions (PH > 7), heat-transfer oils (maximum working temperature depending on the oil quality). Do not use in wells or in water that has circulated through copper piping.

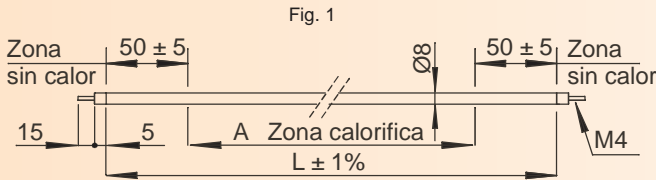

Fig. 1

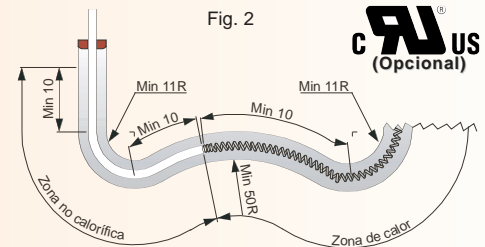

Fig. 2

CAUS
(Opcional)

These heating elements can be bent up to a radius of 11 mm.

IMPORTANT: The two ends of the heated area must be kept at least 10mm away from any curve of a radius under 50 mm. as shown in Fig. 2.
CURVE ON THE ENDS: on the two ends of the pipe at least 10mm must be left without bending.

Code	Dimensions in mm		Seal type	Electricfor's constructive thermic class	Watts	W/cm ²	Weight in Kg
	A	L					
RR0,5S	400	500	Silicone 200	T-700-T	500	5	0,10
RR0,75S	650	750	Silicone 200	T-700-T	750	4,6	0,16
RR1S	900	1000	Silicone 200	T-700-T	1000	4,5	0,22
RR1,5S	1400	1500	Silicone 200	T-700-T	1500	4,3	0,32
RR2S	1900	2000	Silicone 200	T-700-T	2000	4,2	0,43
RR2,5S	2400	2500	Silicone 200	T-700-T	2500	4,2	0,54
RR3S	2900	3000	Silicone 200	T-700-T	3000	4,2	0,64
RR0,5R 150	400	500	Resin 150	T-600-S	500	5	0,10
RR0,75R 150	650	750	Resin 150	T-600-S	750	4,6	0,16
RR1R150	900	1000	Resin 150	T-600-S	1000	4,5	0,22
RR1,5R 150	1400	1500	Resin 150	T-600-S	1500	4,3	0,32
RR2R150	1900	2000	Resin 150	T-600-S	2000	4,2	0,43
RR2,5R 150	2400	2500	Resin 150	T-600-S	2500	4,2	0,54
RR3R150	2900	3000	Resin 150	T-600-S	3000	4,2	0,64
RR0,5R 250	400	500	Resin 250	T-600-H	500	5	0,10
RR0,75R 250	650	750	Resin 250	T-600-H	750	4,6	0,16
RR1R250	900	1000	Resin 250	T-600-H	1000	4,5	0,22
RR1,5R 250	1400	1500	Resin 250	T-600-H	1500	4,3	0,32
RR2R250	1900	2000	Resin 250	T-600-H	2000	4,2	0,43
RR2,5R 250	2400	2500	Resin 250	T-600-H	2500	4,2	0,54
RR3R250	2900	3000	Resin 250	T-600-H	3000	4,2	0,64

RTR

GROUP 2A - Heating elements for air and/or immersion

2A.2 One-pipe straight elements vulcanised in stainless steel

General features

- One-pipe elements reinforced in AISI 304 stainless steel, Ø9.65 mm, insulated heating element with electrofused magnesium oxide compressed by flat-rolling.
- Vulcanised cap with IP-65 protection
- Finishings with silicon cables 700mm long.
- Standard voltage ~230 V

Usual applications

- Support elements for Fan-Coil
- Working in air.** Always with forced ventilation and inserted in heat exchange battery with flaps. Please consult our Technical Department if you have any queries.
- Working in immersion.** Can be used in water with low chlorine content (natural water).

Also for neutral and alkaline aqueous solutions (PH > 7), heat-transfer oils (maximum working temperature depending on the oil quality). Do not use in wells or in water that has circulated through copper piping.

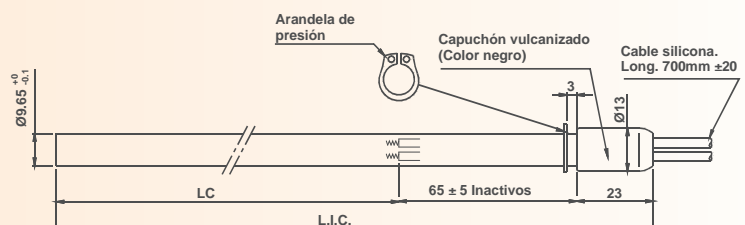

Code	Dimensions in mm		Electricfor's constructive thermic class	Watts	W/cm ²	Weight in Kg
	L.I.C.	LC				
F81436	388	300	T-300-E	530	6,1	0,20
F81701	1188	1100	T-300-E	1970	6,0	0,50
F81702	788	700	T-300-E	530	2,5	0,35
F81703	988	900	T-300-E	750	2,8	0,20





RKF flat tubular elements have a wide range of applications. Its oval-shaped cross-section is particularly adapted to contact heating. The larger contact surface area of these resistors compared to round-tube resistors enables production of shorter resistors with higher load densities.

For oil heating, it is possible to install greater power with the same length as a round-tube resistor. As a result of its good flexibility, these elements can be bent to give shape to almost any application.

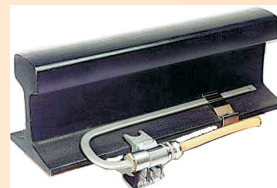

Common applications

- Gas or air heaters
- Fluid heating
- Oil heating
- Driers
- Friers
- Mould heating
- Filters
- Liquid containers
- Conveyor-belt heating
- **Special applications:** Railway and tramway heaters; needle changes.

General characteristics



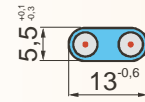
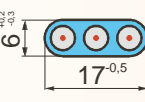
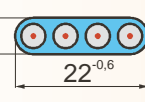

- Flat tubular elements with stainless-steel AISI 321 sleeve, 80-20 grade nickelchromium alloy resistive wire insulated from the sleeve with highly compacted magnesium oxide of very good thermal conductivity.
- Ohmic values:
 - Minimum: 8 Ω per metre
 - Maximum: 1500 Ω per metre for a resistor of 2 conductors.
- Maximum length:
 - RKF 13 → 7000 mm
 - RKF 17 → 5,000 mm
 - RKF 22 → 5,000 mm
- Length tolerance: ±1% with a minimum of ±5 mm
- Inactive zone: Due to the production process, all RKF flat tubular elements have an inactive zone at the connections side of a minimum of 45 mm and at the tube end of a minimum of 25 mm.
- Connections: Smooth outlet Ø1.8 x 30 mm. Other connection possibilities on request.
- Special fabrications: RKF flat tubular elements can be supplied with longer inactive zones. They can also be fabricated with different power distributions over the length.

Sections

- 
 - **RKF 13. Section 13 x 5.5 mm**
 - In this section, the resistor has an approximate surface area of 3.3 cm² per cm of length. The maximum length is 7000 mm. In railway heating applications, we can supply standard models with different power densities and sealed connection.
- 
 - **RKF 17. Section 17 x 6 mm**
 - In this section, the resistor has an approximate surface area of 4.1 cm² per cm of length. The maximum length is 5,000 mm. This is the most commonly used model in industrial applications. Its greater length enables a wide variety of shapes to be produced, as well as different internal resistor layouts and power distributions.
- 
 - **RKF 22. Section 22 x 6 mm**
 - In this section, the resistor reaches an approximate surface area of 5.1 cm² per cm of length. The maximum length is 5,000 mm. As with type RKF 17, it is possible to produce a wide variety of internal resistor layouts.

Internal resistor layout

The RKF flat tubular elements can be fabricated with different internal resistor layouts. We can obtain different power levels in the same element by means of connections. The following illustrations show the connection possibilities for each model.

		
<ul style="list-style-type: none"> • Profile type: RKF 13 / RKF 17 / RKF 22 • Description: Single-phase resistor with two outputs at one end 	<ul style="list-style-type: none"> • Profile type: RKF 13 / RKF 17 / RKF 22 • Description: Two single-phase resistors with two outputs at both ends 	<ul style="list-style-type: none"> • Profile type: RKF 17 / RKF 22 • Description: Three single-phase resistors with two outputs at both ends
		
<ul style="list-style-type: none"> • Profile type: RKF 22 • Description: Single-phase resistor with two outputs at one end 	<ul style="list-style-type: none"> • Profile type: RKF 22 • Description: Two single-phase resistors with four outputs at one end. Maximum voltage 400 V 	

Bending

RKF flat tubular elements are supplied straight unless specified otherwise. On request, these elements can be supplied bent according to the instructions given by the client, always taking into account the minimum radii of curvature.

In order to achieve maximum torsion of 90°, a minimum length of 25 mm is required. It is not recommended to change the shape of the resistor in any way between the inactive zone and the connection.

The following minimum radii of curvature must be taken into account when bending the resistor:

Minimum radius of curvature

	RKF 13	RKF 17	RKF 22
Flat-face curves	10 mm	12,5 mm	18 mm
Curves at edges	20 mm	25 mm	75 mm





In the chemical and petrochemical industries, industrial processes, oil rigs and military installations there are materials which are stored, processed or produced in areas where the atmosphere is potentially explosive and in which explosion-proof heating elements are required. In these cases we must take preventive measures to reduce the risk of explosion of these materials. These preventive measures are based on three principles that they should be applied in the following order:

- **Substitution:** Substitution means replacing flammable material for non-flammable material.
- **Control:** Control means to reduce the amount of flammable material; avoid, minimize or control the leaks, avoid the formation of an explosive atmosphere, containment of leaks, avoid ignition sources, etc...
- **Reduction:** Reduction means to reduce the number of people exposed, measures to prevent the explosion's spread, reduction or elimination of the explosion pressure, providing personnel protective equipment, etc...

Once the principles of replacement and control are applied, the remaining hazardous locations are divided into zones according to the possibility an explosive zone could be present. This classification allows to determine the protection levels for the material and the suitable protection modes for each location.

For an explosion to occur, is necessary to coexist an explosive atmosphere and an ignition source.

The purpose of protective measures on Electricfor's ATEX heating elements is to reduce, until an acceptable level, the probability that the heating elements could become a source of ignition, both surface temperature and electric arc.

For the purposes of Directive 94/9/CE, an explosive atmosphere is defined as a mixture with the air in the atmospheric conditions of inflammable substances in the form of gases, steam, clouds or dust, in which, after igniting, combustion spreads to the total amount of the non-burnt mixture. According to the standard, it is understood as normal atmospheric conditions when:

- The temperature is within the range -20 ° C to +60 ° C
- The pressure is within the range 0.8 bar to 1.1 bar
- The air has a normal oxygen content (typically 21%)

The use of electrical equipment in atmospheric conditions out of this range requires special consideration and may require additional evaluation and testing.

Material groups

Electrical material in Group I is applied in mines with danger of firedamp occurring.

Electrical equipment Group II is intended for use in locations with explosive gas atmosphere different from mines susceptible to firedamp. We assimilate it to industry.



Mining

Industry

Classification of the dangerous zones (According to EN 60079-10)

Explosive atmospheres are classified by zones according to EN 60079-10. Classification by zones depends on the time and spatial probability of a dangerous explosive atmosphere occurring.

Zone Classification		Criterion
Gas	Dust	
Zone 0	Zone 20	Presence of permanent, prolonged, or frequent explosive atmosphere (> 1000 hours a year)
Zone 1	Zone 21	Presence of occasional explosive atmosphere in normal conditions (10 - 1000 hours a year)
Zone 2	Zone 22	Presence of abnormal and brief explosive atmosphere (< 10 hours a year)

Category of equipments Acc. Directive

- **Category 1:** Equipment designed to ensure a very high level of protection and intended for use in areas in which explosive atmospheres caused by mixtures of air and gases, vapours or mists or by air/dust mixtures are present continuously, for long periods or frequently.
- **Category 2:** Equipment designed to ensure a high level of protection and intended for use in areas in which explosive atmospheres caused by gases, vapours, mists or air/dust mixtures are likely to occur occasionally.
- **Category 3:** Equipment designed to ensure a normal level of protection and intended for use in areas in which explosive atmospheres caused by gases, vapours, mists, or air/dust mixtures are unlikely to occur or, if they do occur, are likely to do so only infrequently and for a short period only.

Types of explosive atmospheres Acc. Directive

- **G:** Gases, vapours or mists
- **D:** Dusts

Gas groups Acc. standard EN 60079-0

The electrical equipment of group II (Industry) is subdivided according to the nature of the explosive gas atmosphere for which it is intended

This subdivision is based on the maximum experimental safe gap (MESG) or the ratio of minimum ignition current (MIC ratio) of the explosive gas atmosphere in which the material can be installed.

Examples of classifications of a few representative gases:



Industry

	IIA	IIB	IIC
T1	Propane - Methane - Ethane - Benzene - Ammonia - Methane	Vinyl Cyanide	Hydrogen
T2	Ethanol - Butane	Ethylene	Acetylene
T3	Gasol - Hexane	Sulfuric Ac.	
T4	Acetaldehyde	Ethyl ether	
T5			
T6			Carbon Bisulfide

Dust groups Acc. standard EN 60079-1

The electrical equipment of group II (Industry) is subdivided according to the nature of the explosive dust atmosphere for which it is intended

Group IIIA	Group IIIB	Group IIIC
Combustible particles in suspension	Nonconductive dust	Conductive dust

Note:

- A unit for Gas Group IIC is suitable also for Groups IIA and IIB
- A unit for Gas Group IIB is also suitable for Groups IIA

Note:

- A material marked with IIC is suitable also for Groups IIA and IIB
- A material marked with IIB is also suitable for Groups IIA

Group and category of equipment

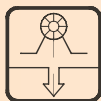

Mining



Industry

Group	Acc. directive 2014/34/EU		Acc. standard EN 60079-0		Acc. standard EN 60079-10
	Protection level	Category	Group	EPL	
I	Very High	M1	I	Ma	Not applicable
	High	M2		Mb	
II	Very High	1G	Gases	Ga	0
	High	2G	II (IIA - IIB - IIC)	Gb	1
	Normal	3G		Gc	2
	Very High	1D	Dusts	Da	20
	High	2D	II (IIA - IIB - IIC)	Db	21
	Normal	3D		Dc	22

EPL (Equipment Protection Level) Acc. standard EN 60079-0

Protection level is assigned to the material according to their risk of becoming a source of ignition and which recognize the differences between explosive gas atmospheres, explosive dust atmospheres and explosive atmospheres in mines susceptible to firedamp

- Mines: Ma y Mb
- Gases: Ga, Gb y Gc
- Dust: Da, Db y Dc





Protection methods

Protection methods are constructive and electrical measurements taken on the material to achieve protection against explosion in potentially explosive atmospheres.

Protection Type	Identification Letter	Diagram Representation	Basic Principle
General requirements			General determinations on the build type and test of electrical material intended for Ex atmospheres
Immersion in oil	Ex o		The material or its components are kept immersed in oil and thus separated from the explosive atmosphere
Pressurised	Ex px Ex py Ex pz		The ignition source is surrounded by a protective gas under overpressure (min. 0.5 mbar); the external atmosphere cannot penetrate
Pulverulent	Ex q		The ignition source is surrounded by fine-grain sand. The Ex atmosphere surrounding the casing cannot be ignited by an arc
Flame proof	Ex d		If ignition is produced inside the envelope, the latter will resist the pressure, that is, the explosion will not propagate to the exterior.
Increased safety	Ex e		Applicable only to material or its components that in normal circumstances do not generate sparks or electric arcs, cannot reach dangerous temperatures, and whose supply voltage does not exceed 1 kV.
Intrinsic safety	Ex ia Ex ib Ex ic		Limiting the energy already in the circuit prevents the onset of excessive temperatures, sparks, or electric arcs
Encapsulated	Ex ma Ex mb Ex mc		The ignition source is enclosed inside a mass, and cannot therefore ignite the explosive atmosphere
Non-flammable	Ex nA Ex nC Ex nR		Slightly simplified application of the different protection modes of zone 2; "n" means "non-flammable"
By enclosure	Ex ta Ex tb Ex tc		The electrical equipment are protected by an enclosure which prevents the ignition of a dust cloud or layer

Temperature classes

The ignition temperature of an inflammable gas or dust is the lowest temperature on a hot surface from which ignition of the gas/air or steam/air mixture occurs. Therefore, the maximum surface temperature of a material must always be lower than the inflammability temperature of the surrounding atmosphere. To that end we identify indicating the maximum surface temperature they can reach. In gases is indicated by T1 to T6 (see table below) and for dust we directly indicate this temperature.

Temperature class	Maximum material surface temperature	Flammable substances ignition temperatures
T1	450 °C	> 450 °C
T2	300 °C	> 300 °C
T3	200 °C	> 200 °C
T4	135 °C	> 135 °C
T5	100 °C	> 100 °C
T6	85 °C	> 85 °C

Temperature class GAS

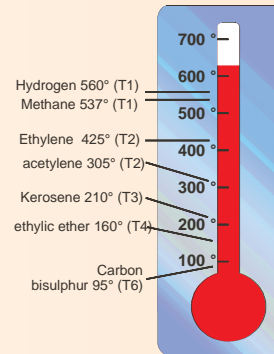

Temperature class DUST

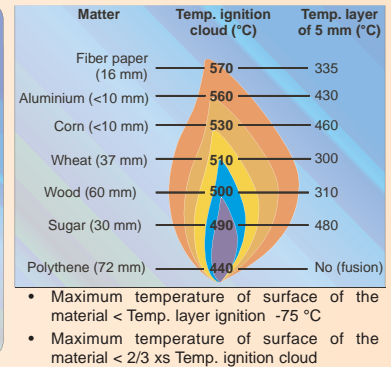

Marcado ATEX

See below the explanation of the meaning of the following ATEX marking, taking as an example:

CE 0163 Ex II 2 GD - Ex d IIC T4 Gb - Ex tb IIC T135°C Db

The marking is divided into five parts:

- General according directive 2014/35/EU

CE 0163	
CE ⇒	CE marking - Product manufactured according to directive
0163 ⇒	ATEX notified organism number (LOM)

- Specific for gases according directive 2014/35/EU

Ex II 2 G	
Ex ⇒	Specific brand of electrical equipment for explosive atmospheres
II ⇒	Industry (not including mines with firedamp risks)
2 ⇒	HIGH level of protection
G ⇒	Suitable for gases, vapours and mists

- Specific for gases according standard EN 60079-0

EX d IIC T4 Gb	
Ex ⇒	Symbol indicating that the material corresponds according to standard protection.
d ⇒	Enclosure Explosion-proof "d"
IIC ⇒	Suitable for gas group IIC
T4 ⇒	Temperature class (T1 to T6)
Gb ⇒	Material for explosive gas atmospheres with a HIGH level of protection

- Specific for dusts according directive 2014/35/EU

Ex II 2 D	
Ex ⇒	Specific brand of electrical equipment for explosive atmospheres
II ⇒	Industry (not including mines with firedamp risks)
2 ⇒	HIGH level of protection
G ⇒	Suitable for dusts

- Specific for dusts according standard EN 60079-0

Ex tb IIC T135°C Db	
Ex ⇒	Symbol indicating that the material corresponds according to standard protection.
tb ⇒	Protection mode that has an enclosure that protects against dust entering and provides a means to limit the surface temperature. Suitable for EPL Db
IIC ⇒	Nature of the dust - conducting dust
T135°C ⇒	Maximum surface temperature
Db ⇒	Material for explosive dust atmospheres with a HIGH level of protection

Relationship between modes of protection and the EPLs

EPL	Protection mode	Code	Standard
Ga	Intrinsic safety	"ia"	IEC 60079-11
	Encapsulated	"ma"	IEC 60079-18
	Two independent protection modes each one according to EPL "Gb"		IEC 60079-26
Gb	Protection of equipment and transmission systems which use optical radiation		IEC 60079-28
	Flameproof enclosures	"d"	IEC 60079-1
	Increased safety	"e"	IEC 60079-7
	Intrinsic safety	"ib"	IEC 60079-11
	Encapsulated	"m" "mb"	IEC 60079-18
	Immersion in oil	"o"	IEC 60079-6
	Pressurised enclosures	"p" "px" "py"	IEC 60079-2
	Pulverulent	"q"	IEC 60079-5
	Concept intrinsically safe fieldbus (FISCO)		IEC 60079-27
	Protection of equipment and transmission systems which use optical radiation		IEC 60079-28
Gc	Intrinsic safety	"ic"	IEC 60079-11
	Encapsulated	"mc"	IEC 60079-18
	No sparks producer	"n" "nA"	IEC 60079-15
	Restricted breathing	"nR"	IEC 60079-15
	Power limitation	"nL"	IEC 60079-15
	Material that produces sparks	"nC"	IEC 60079-15
	Pressurised enclosures	"pz"	IEC 60079-2
	Concept Fieldbus non-incendive		IEC 60079-27
Protection of equipment and transmission systems which use optical radiation		IEC 60079-28	
Da	Intrinsic safety	"ia"	IEC 60079-11
	Encapsulated	"ma"	IEC 60079-18
	Protection by enclosure	"ta"	IEC 60079-31
Db	Intrinsic safety	"ib"	IEC 60079-11
	Encapsulated	"mb"	IEC 60079-18
	Protection by enclosure	"tb"	IEC 60079-31
	Pressurised enclosures	"pd"	IEC 61241-4
Dc	Intrinsic safety	"ic"	IEC 60079-11
	Encapsulated	"mc"	IEC 60079-18
	Protection by enclosure	"tc"	IEC 60079-31
	Pressurised enclosures	"pd"	IEC 61241-4



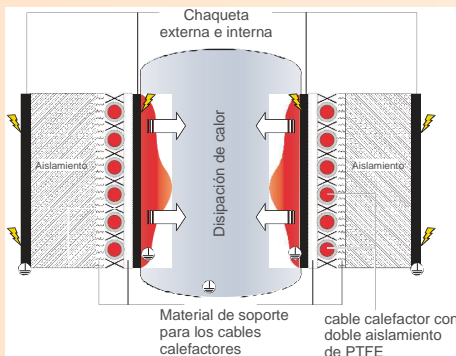

FLEXIBLE HEATER BLANKETS FOR DRUMS OF 200 L, ATEX CERTIFIED. AFW-ATX MODELS

The AFW-ATX type explosion protected heating jackets can be used in gas and dust areas Zone 1/2 (Gas) and Zone 21/22 (dust) and are therefore universally applicable for diverse sectors and industrial applications (explosion groups IIC hydrogen and for IIIC conductive dusts) with necessary process-related heating.

Very robust construction made of high quality, durable materials. Indoor and outdoor use possible. Protection classes: Gas IP64 / dust IP6X. Wide range of variants in terms of dimensions, contours and fixation options cover most heating applications.

High flexibility AND simple assembly. The heating jackets are delivered completely ready configured and can be connected and put into operation immediately without further acceptance procedures.

General characteristics

- ATEX certified. Gas EX II 2G Ex e mb IIC T3 Gb - Dust EX II 2D Ex e mb IIIC T120°C Db
- EC-type examination certificate: TPS 11 ATEX 29587 011 X
- Heating power depending on design (max. 30W/m heat conductor load)
- Max. admissible operating temperature 180°C
- Temperature class T6, T5, T4, max.T3 (depending on temperature setting controller / limiter)
- Max. temperature limit in gas atmospheres + 200 °C (180°C / 190°C)
- Max. temperature limit in dust atmospheres + 120 °C (100°C / 110°C)
- Ambient Operation ambient temperature: -40°C to +60°C
- Moisture-proof IP 65.
- Outer shell: electrostatic dissipative PTFE-coated glass fiber fabric
- Closure: straps with buckles
- Termination boxes for mains supply (via controller) and sensors mounted on outer face and ready for connection. Sensor 2 x Pt100 ATEX
- Connecting cable power and sensor separate 3,0 m long.
- By request, other power and dimensions ca be made according to your specifications.

Standard models

Code	Volts	Watts	Dimensions in mm		Temperature class	Max. operating temperature
			Wide	Length		
AFW-ATX-200	230 Vac	1200	800	2100	T3	180 °C



IBC INTERMEDIATE 1000 L CONTAINER HEATERS, ATEX CERTIFIED. IBCW-ATX MODELS

Los calentadores para contenedores intermedios IBC de 1000 lts IBCW-ATX certificados ATEX son aptos para su uso en Zonas 21 y 22 de gas y polvo. Son por lo tanto de aplicación universal para diversos sectores y aplicaciones industriales (grupos de explosión IIC hidrógeno y para polvos conductores IIIC). Construcción muy robusta hecha con materiales de alta calidad. Puede trabajar tanto en interior como en exterior.

Amplia gama de variantes en cuanto a dimensiones, formas y opciones de fijación que cubren la mayoría de aplicaciones de calefacción.

Alta flexibilidad e instalación sencilla. Listo para la conectar. Las mantas calefactoras se entregan listas para conectar y poner en marcha de inmediato.

General characteristics

- ATEX certified. Gas EX II 2G Ex e mb IIC T3 Gb - Dust EX II 2D Ex e mb IIIC T120°C Db
- EC-type examination certificate: TPS 11 ATEX 29587 011 X
- Heating power depending on design (max. 30W/m heat conductor load)
- Max. admissible operating temperature 180°C
- Temperature class T6, T5, T4, max.T3 (depending on temperature setting controller / limiter)
- Max. temperature limit in gas atmospheres + 200 °C (180°C / 190°C)
- Max. temperature limit in dust atmospheres + 120 °C (100°C / 110°C)
- Ambient Operation ambient temperature: -40°C to +60°C
- Moisture-proof IP 65.
- Outer shell: electrostatic dissipative PTFE-coated glass fiber fabric
- Closure: straps with buckles
- Termination boxes for mains supply (via controller) and sensors mounted on outer face and ready for connection. Sensor 2 x Pt100 ATEX
- Connecting cable power and sensor separate 3,0 m long.
- By request, other power and dimensions ca be made according to your specifications.

Standard models

Code	Volts	Watts	Dimensions in mm		Temperature Class	Max. operating temperature
			Wide	Length		
IBCW-ATX-1000	230 Vac	2400	1000	4400	T3	180 °C
TIBCW-ATX	ATEX Insulating jacket for IBC-container 1000 L					90 °C



GROUP 3 - Heating equipment able to be used in potentially explosive atmospheres

HCW

3.4 - ATEX certified heating blankets for gas cylinders



ATEX CERTIFIED HEATING BLANKETS FOR GAS CYLINDERS, GCW-ATX MODELS

For use in hazardous areas of Zone 1/2 and 21/22

- They improve control of the process and reduce losses of condensate gas
 - They create convection current
 - They increase pressure inside the cylinder
- They fit most gas cylinders
- Complete coverage of the surface
- The insulation reduces heat losses
- Models for potentially explosive atmospheres

General characteristics

- Max. admissible operating temperature 180 °C
- Sensor 2 x Pt100 ATEX; cables long 3000mm
- Connecting cable power and sensor separate 3,0 m long.
- Temperature class T3
- Heater support a double glass fiber fabric
- Heater cable: PTFE-insulated with PE braiding and outer jacket
- Insulation material / thickness: glass needle mat / 20 mm approx.
- Outer shell: electrostatic dissipative PTFE-coated glass fiber fabric.
- Closure: straps with buckles
- Class I electric equipment
- Moisture-proof IP 64.
- Ambient Operation ambient temperature: -40°C to +60°C
- EC-type examination certificate: TPS 11 ATEX 29 587 011 X
- ATEX Identification:
 - Gas Ex II 2G Ex e mb IIC T3 Gb
 - Dust Ex II 2G Ex e mb IIIC T120 °C Db
- By request, other power and dimensions ca be made according to your specifications

Code	Dimensions in mm		Gas bottle capacity	Volts	Watts
	Øint	Height			
GCW-ATX-10	Ø140	800	10 Lts	~ 230 V	380
GCW-ATX-50	Ø230	1400	50 Lts	~ 230 V	850

NOTE: The heating sleeve must be temperature controlled and limited to the permitted temperature class

GROUP 3 - Heating equipment able to be used in potentially explosive atmospheres

3.5 - Controladores de temperatura para equipos de calefacción ATEX



ATEX-Temperature controller / limiter / energy controller for use with explosion proof heating equipment, installation in hazardous area is permitted, ATEX approved. For use in hazardous areas of Zone 1/2 and 21/22

General characteristics

- Sensor 2 x Pt100 ATEX.
- Temperature range: 0...450 °C.
- Class I electric equipment
- Moisture-proof IP 64.
- Ambient temperature range: -20 °C a + 40 °C
- EC-type examination certificate: TÜV 10 ATEX 556065
- ATEX identification:
 - Gas Ex II 2G Ex e ib [ib Gb] mb IIC T4 Gb
 - Dust Ex II 2D Ex tb IIIC IP6X T90 °C Db

Code	Temperature range	Dimensions in mm	Switching current	Volts	Weight in Kg
CLT-ATX	0 / 450 °C	260 x 160 x 135	25 A	~ 230 V	6,0

NEW

CLT-ATX

GROUP 3 - Heating equipment able to be used in potentially explosive atmospheres

3.6 - Canister heater for classified zones

DRUM HEATER FOR CLASSIFIED ZONES, MODEL HIDH

The HIDH drum heater for areas with potentially explosive atmospheres is designed for heating standardised 205-litre drums or small steel tanks. The HIDH drum heater is composed of one single induction reel, which is encapsulated in a cylinder made of a reinforced glass resin material. The reel is connected to the current and generates heat directly and uniformly over the canister walls. Energy transfer is carried out by magnetic field. In this way there is no thermal transmission by conventional radiation or convection means. As there are no hot elements, the reel will remains substantially colder than the drum that is being heated.

Safety

The complete absence of hot elements and encapsulation of all electrical components allows its use in Zone 1 & 2 classified area. The HIDH drum heater is certified ATEX Ex II 2 G/D EEx'e' IIC T3 (170 °C). Uniform heating without hot points reduces the deterioration risk of the product.

Performance

The low temperature of the system and non-existence of heat losses by thermal transmission lead to the high efficiency of the induction heater. In comparison with conventional canister heaters, an energy saving of up to 50% is achieved.

Speed

Heating times will depend on the contents of the canister, but to give an approximate idea, the temperature rise ramp with a typical organic viscose liquid is about 15°C/hour. Using the complete surface of the heater wall to transmit energy, the optimum and quickest working point can be achieved without the product undergoing deterioration.

Maintenance

Without heating elements and without moving parts, the HIDH drum heaters have a virtually unlimited life, and do not require any maintenance.

Usual applications

- Gas bottles
- Small scale reactors
- Process containers
- Chemical industry
- Pharmaceutical industry
- Petrochemical industry
- Paint warehouses.

Standard models

Model	Volts	Watts (operating)	Dimensions in mm			Weight in Kg
			Ø Exterior	Ø Interior	Height	
HIDH-2,25	~240	2250	Ø743	Ø613	711	48

General characteristics

- Certified ATEX Ex II 2 G/D EEx'e' IIC T3 , according to EN 50014 and EN 50019
- IP-66 damp protection rating
- Class II electrical equipment
- Supply voltage ~240 V, 50Hz
- Consumed power/Intensity:
 - On: 2750 W / 21A
 - (Inductive power factor) In state: 2250 W / 18A

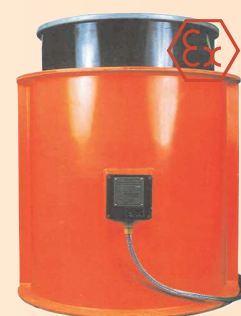

HIDH

IMMERSION HEATERS WITH SCREW CAP AND TUBULAR HEATING ELEMENTS, REX-TR RANGE



The REX-TR range of tubular immersion heaters is apt for installation in process tanks, safety baths, motor oil collectors, pressure receivers, and similar equipment, located in hazardous areas classed as Zone 1 and Zone 2 where the flammable atmosphere is Group IIA, IIB, or IIC. Apt for heating of liquid or gas that is not corrosive to the heater materials.

Common applications

- Water or oil preheating
- Cleaning and flushing tanks
- Process equipment
- Heat-transfer systems
- Boilers
- Anti-icing protection

General characteristics

- Certificate ATEX Ex II 2 G/D EEx'd' IIC T3 to T6, in accordance with EN 50014 and EN 50018
- Aluminium terminal box with damp protection IP65
- Integrated temperature sensor
- Valid for ambient temperature down to -40 °C
- Heater coupling using 2" - 2"¼ - 2"½ screw cap
- Designed exclusively for horizontal fitting. Vertical fitting available on request.

- **Terminal box:** Aluminium box with a maximum of 2 inputs for cables, internal and external earth connection, and screw cap. ATEX II 2 G/D EEx'd' IIC T4 to T6 with optional T3 to T6 if the terminal box is separated from the coupling cap. Damp protection grade IP65.
- **Heating components:** Maximum of three tubular elements, fabricated with NiCr 80/20 alloy resistive wire, compacted magnesium oxide, and tubular sleeve made of copper, steel, Monel, Inconel, Incoloy 800/825, stainless steel, or titanium, welded to the cap by brazing or TIG welding depending on the application.
- **Controls:** REX-TR heaters incorporate overtemperature protection by default. Other temperature devices such as thermostats, thermoresistors, or thermocouples may be incorporated as options.
- **Coupling:** Within the design limits, it is possible to specify the thread and material of the coupler cap.

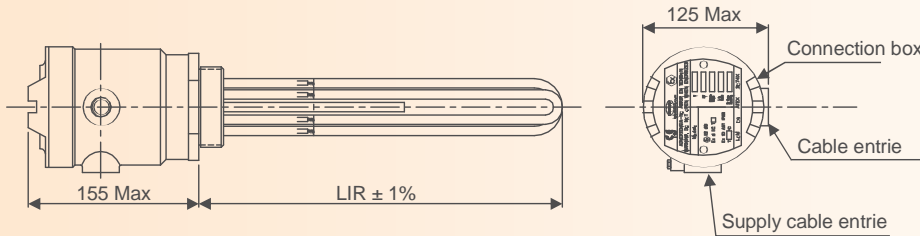

Standard REX-TR models with 2"½ stainless-steel AISI 316L screw cap

Standardized models especially designed for use in Biofuel equipment.

Code	LIR in mm	Volts	Watts	W/cm²	Tube material	Thermostats temperature range	
						control	safety
REX-TR-3-15-DS	381	3~230 Δ 3-400 A	3000	4,7	AISI 321 Ø10	0 / +90 °C	+95 °C
REX-TR-6-27-DSZ	686	3~230 Δ 3-400 A	6000	2,8	AISI 321 Ø10	0 / +90 °C	+95 °C
REX-TR-12-27-DSZ	686	3~230 Δ 3-400 A	12000	5,3	AISI 321 Ø10	0 / +90 °C	+95 °C

Standard REX-TR models with 2" brass screw cap.

Code	LIR in mm	Volts	Watts	W/cm²	Tube material	Thermostats temperature range	
						control	safety
REX-TR-111	280	~230	1000	8,4	Incoloy-825 Ø8	0 / +90 °C	+20 / +120 °C
REX-TR-211	280	~230	2000	5,7	Incoloy-825 Ø8	0 / +90 °C	+20 / +120 °C
REX-TR-311	280	3~230 Δ 3-400 A	3000	8,4	Incoloy-825 Ø8	0 / +90 °C	+20 / +120 °C
REX-TR-330	762	3~230 Δ 3-400 A	3000	2,8	Incoloy-825 Ø8	0 / +90 °C	+20 / +120 °C
REX-TR-616	406	3~230 Δ 3-400 A	6000	11,2	Incoloy-825 Ø8	0 / +90 °C	+20 / +120 °C
REX-TR-630	762	3~230 Δ 3-400 A	6000	5,6	Incoloy-825 Ø8	0 / +90 °C	+20 / +120 °C
REX-TR-916	406	3~230 Δ 3-400 A	9000	16,8	Incoloy-825 Ø8	0 / +90 °C	+20 / +120 °C
REX-TR-923	584	3~230 Δ 3-400 A	9000	11,2	Incoloy-825 Ø8	0 / +90 °C	+20 / +120 °C
REX-TR-926	660	3~230 Δ 3-400 A	9000	9,8	Incoloy-825 Ø8	0 / +90 °C	+20 / +120 °C
REX-TR-1223	584	3~230 Δ 3-400 A	12000	14,8	Incoloy-825 Ø8	0 / +90 °C	+20 / +120 °C
REX-TR-1233	838	3~230 Δ 3-400 A	12000	10,1	Incoloy-825 Ø8	0 / +90 °C	+20 / +120 °C

Standard REX-TR models with 2" stainless-steel screw cap.

Code	LIR in mm	Volts	Watts	W/cm²	Tube material	Thermostats temperature range	
						control	safety
REX-TR-111S	280	~230	1000	8,4	Incoloy-825 Ø8	0 / +90 °C	+20 / +120 °C
REX-TR-211S	280	~230	2000	5,7	Incoloy-825 Ø8	0 / +90 °C	+20 / +120 °C
REX-TR-311S	280	3~230 Δ 3-400 A	3000	8,4	Incoloy-825 Ø8	0 / +90 °C	+20 / +120 °C
REX-TR-330S	762	3~230 Δ 3-400 A	3000	2,8	Incoloy-825 Ø8	0 / +90 °C	+20 / +120 °C
REX-TR-616S	406	3~230 Δ 3-400 A	6000	11,2	Incoloy-825 Ø8	0 / +90 °C	+20 / +120 °C
REX-TR-630S	762	3~230 Δ 3-400 A	6000	5,6	Incoloy-825 Ø8	0 / +90 °C	+20 / +120 °C
REX-TR-916S	406	3~230 Δ 3-400 A	9000	16,8	Incoloy-825 Ø8	0 / +90 °C	+20 / +120 °C
REX-TR-923S	584	3~230 Δ 3-400 A	9000	11,2	Incoloy-825 Ø8	0 / +90 °C	+20 / +120 °C
REX-TR-926S	660	3~230 Δ 3-400 A	9000	9,8	Incoloy-825 Ø8	0 / +90 °C	+20 / +120 °C
REX-TR-1223S	584	3~230 Δ 3-400 A	12000	14,8	Incoloy-825 Ø8	0 / +90 °C	+20 / +120 °C
REX-TR-1233S	838	3~230 Δ 3-400 A	12000	10,1	Incoloy-825 Ø8	0 / +90 °C	+20 / +120 °C





IMMERSION HEATERS WITH SCREW CAP, CASING, AND CERAMIC BODY INTERIOR, RFA-C RANGE

The 'RFA-C' range of immersion heaters with casing and replaceable ceramic interior provides a good solution for areas classified for oil heating or other similar processes in which a low load density is required. The heating element can be removed for inspection or replaced without the need to empty the tank. The EEx'd' terminal box protects the electrical connections from the explosive atmosphere.



Common applications

- Water or oil preheating
- Cleaning and flushing tanks
- Process equipment
- Heat-transfer systems
- Boilers
- Anti-icing protection

General characteristics

- Certificate ATEX Ex II 2 G/D EEx'd' IIC T3 to T6, in accordance with EN 50014 and EN 50018
- Aluminium terminal box with damp protection IP67
- Integrated temperature sensor
- Valid for ambient temperature down to -40 °C
- Heater coupling using 2”½ screw cap. It can be fabricated with any other type of standardised thread or flange on request
- Designed exclusively for horizontal fitting. Vertical fitting available on request.

- **Terminal box:** Aluminium box with a maximum of 2 inputs for cables, internal and external earth connection, and screw cap. Damp protection grade IP67.
- **Heating components:** Replaceable ceramic component with high-quality nickel-chromium 80-20 resistive wire
- **Casing:** Standard steel or stainless-steel AISI 316L models. On request, it can be fabricated from Monel, Incoloy, Inconel, or titanium and welded according to the application.
- **Controls:** RFA-C heaters incorporate overtemperature protection by default. Other temperature devices such as thermostats, thermoresistors, or thermocouples may be incorporated as options.
- **Coupling:** Within the design limits, it is possible to specify the thread and material of the coupler cap.
- **Power:** Maximum power: 14.5 kW
- **Power supply:** Voltages possible up to -690 V

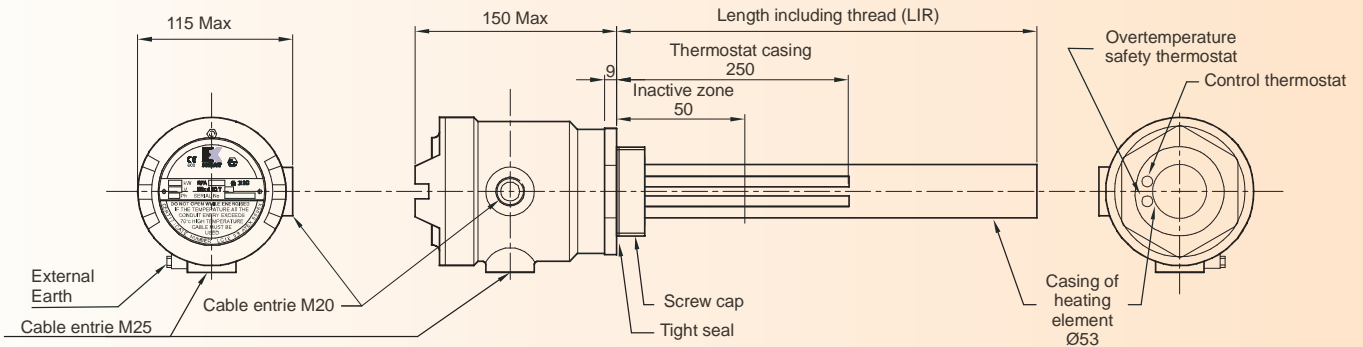

Standard RFA-C models with brass 2”½ screw cap and carbon-steel casing

Code	LIR in mm	Volts	Watts	W/cm ²	Material tube	Thermostats temperature range	
						control	safety
RFA-CM1-16D	406	~240	1000	1,5	Carbon Steel	+5 / +80 °C	+45 / +95 °C
RFA-CM2-32D	812	3~240 Δ 3~415 A	2000	1,5	Carbon Steel	+5 / +80 °C	+45 / +95 °C
RFA-CM3-48D	1219	3~240 Δ 3~415 A	3000	1,5	Carbon Steel	+5 / +80 °C	+45 / +95 °C
RFA-CM4-64D	1626	3~240 Δ 3~415 A	4000	1,5	Carbon Steel	+5 / +80 °C	+45 / +95 °C
RFA-CM5-80D	2032	3~240 Δ 3~415 A	5000	1,5	Carbon Steel	+5 / +80 °C	+45 / +95 °C
RFA-CM6-99D	2515	3~240 Δ 3~415 A	6000	1,5	Carbon Steel	+5 / +80 °C	+45 / +95 °C
RFA-CM7-120D	3048	3~240 Δ 3~415 A	7000	1,5	Carbon Steel	+5 / +80 °C	+45 / +95 °C

Choice of control thermostat

The control thermostat can be replaced by another from the following

list at no additional cost. If this is necessary, indicate it in your order:

- Scale: +40 / +80 °C
- Scale: +0 / +40 °C
- Scale: -10 / +65 °C
- Scale: +10 / +90 °C

Standard RFA-C models with stainless-steel 2”½ screw cap and AISI 316L stainless-steel casing

Code	LIR in mm	Volts	Watts	W/cm ²	Tube material	Thermostats temperature range	
						control	safety
RFA-CS1-16D	406	~240	1000	1,5	AISI 316L	+5 / +80 °C	+45 / +95 °C
RFA-CS2-32D	812	3~240 Δ 3~415 A	2000	1,5	AISI 316L	+5 / +80 °C	+45 / +95 °C
RFA-CS3-48D	1219	3~240 Δ 3~415 A	3000	1,5	AISI 316L	+5 / +80 °C	+45 / +95 °C
RFA-CS4-64D	1626	3~240 Δ 3~415 A	4000	1,5	AISI 316L	+5 / +80 °C	+45 / +95 °C
RFA-CS5-80D	2032	3~240 Δ 3~415 A	5000	1,5	AISI 316L	+5 / +80 °C	+45 / +95 °C
RFA-CS6-99D	2515	3~240 Δ 3~415 A	6000	1,5	AISI 316L	+5 / +80 °C	+45 / +95 °C
RFA-CS7-120D	3048	3~240 Δ 3~415 A	7000	1,5	AISI 316L	+5 / +80 °C	+45 / +95 °C

Choice of control thermostat

The control thermostat can be replaced by another from the following

list at no additional cost. If this is necessary, indicate it in your order:

- Scale: +40 / +80 °C
- Scale: +0 / +40 °C
- Scale: -10 / +65 °C
- Scale: +10 / +90 °C



Flange immersion heaters for ATEX/IECEX hazardous areas or in non-ATEX version

Electricfor flange immersion heaters are designed and manufactured according to customer specifications. They are highly performant for heating or maintaining the temperature of gas or liquids.

Reliability and robustness are key drivers for our engineers. After customer specification analysis, our engineers will drive you to the best solution for your process



ATEX / IECEX

Electricfor flange immersions heaters are available in ATEX/IECEX version for class temperature T1 (450°C) to T6 (85°C).

Applications

- Maintaining the temperature and heating of large volumes of liquids or gas
- Heating of circulating or static fluids
- Mounted in tanks, cisterns, boilers or circulation heaters, etc.
- Designed for pressure up to 300 bars
- Power up to 5 MW
- Process temperature up to +450 °C

Advantages

- Large range of materials and options according to customer process and conditions of use
- Equipment available for use in hazardous areas or safe environment
- The end-to-end control of the design and production chain allows us to deliver a product which suits your process perfectly.

Industry sectors

- Petrochemicals
- Chemical industry
- Food industry
- Plastics
- Aeronautics
- Etc.

Temperature control

Temperature sensors (thermostat, limiter, thermocouple or PT100) in the medium (process control) or on the heating element (safety control), on the flange or in the connecting box.

Design of your flange immersion heater

Input data

- A - Application
- B - Type of fluid
- C - Pressure
- D - Inlet and outlet temperature
- E - Flow rate (mass or volume)
- F - Ambient area
- G - Voltage (V)
- H - ATEX/IECEX or not, temperature class
- I - Max. immersed length
- J - Directives, standards, construction codes
- L - Maximum immersed length

Electricfor thermal design and offer

Design procedure to optimize your product

- 1 Power
- 2 Choice of technology and product type
- 3 Watt density (W/cm²)
- 4 Number of heating elements
- 5 Material / Tube diameter
- 6 Type and number of baffles / bundle spider
- 7 Type of flange
- 8 Type of assembly (welding or brazing)
- 9 Heating length (HL)
- 10 Cold length (CL)
- 11 Stand-off length (SOL)
- 12 Cooling discs and heat shields
- 13 Temperature control and safety, type of sensor
- 14 Connecting box / Cable gland
- 15 Other components
- 16 Quotation: price and delivery time

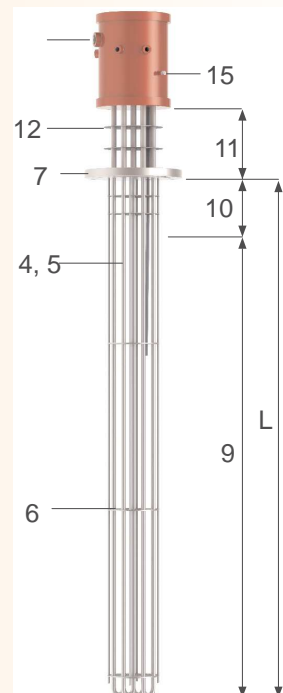

Diseño de un grupo calefactor con brida



Tube materials

- Stainless Steel
 - AISI 321 (DIN 1.4541)
 - AISI 316L (DIN 1.4404)
 - AISI 309 (DIN 1.4828)
 - AISI 304 (DIN 1.4301)
- Others
 - Incoloy 800
 - Incoloy 825
 - Inconel 600
 - Super austenitic 254SMO
 - Titanium
- Specific coating
 - PTFE
 - Halar

Tube diameter

- Ø6.4 / Ø8 / Ø8.5 / Ø10 / Ø12.5 / Ø13.5 / Ø16mm

Flange

- All diameters (including very large sizes)
- EN 1092-1 (European standard, PN)
- EN 1759-1 (European standard, Class)
- ASME B16-5 (American standard)
- Others standards on request

ATEX/IECEx versions

In addition to heater design, the use of specifically developed connection boxes allows to install the products in hazardous areas.

The increased safety protection mode “e” (EN 60079-7) or the explosion-proof protection mode “d” (EN 60079-1), together with temperature control acc. to EN 60079-0, make it possible to operate the equipments in hazardous area (zone 1 and zone 2) for gases of the A-B-C groups.

ATEX housings, types of protection “d” and “e”

- Material choice according to application and standards (carbon steel, stainless steel or others)

Mounting

- Vertical or horizontal position

Electrical

- Voltage: VAC or VCC
- Cabling according to main voltage VAC/VCC 1PH + N or 3PH
- Power: a few Watt to several Megawatts

Connecting box (non-ATEX)

- IP54 / IP65 / IP66 / IP67
- Material: painted steel, stainless steel, aluminium
- Polyamide or nickel-plated brass cable gland

ATEX/IECEx connecting box

- Explosion-proof connecting box, aluminium, stainless steel or painted steel, Ex d IIC
- Stainless steel increased security enclosure, Ex e IIC
- Nickel-plated brass cable gland (stainless steel as option)

Standard documentation

- Certificate of conformity to the order
- Heater wiring diagram
- General drawing
- Instruction manual

On-request documentation

- Supplied according to directives, standard and construction code
- Welder qualifications (WPQR)
- Welding qualifications (WPS)
- REP 97/23 documentation
- Material certificate 3.1 acc. to EN 10204

Certifications (if requested)

- According to standard to comply with
- ATEX/IECEx certificate for component or system
- EAC CU TR, c CSA us (NEC500)

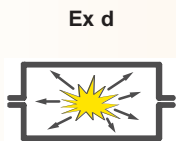

Type of protection “d” explosion-proof housing

Basic principle: If ignition is produced inside the envelope, the latter will resist the pressure, that is, the explosion will not propagate to the exterior.

With this method, the housing (casing):

- Must contain the explosion within the enclosure
- Make sure that the ignition cannot reach the hazardous area
- Always keep an external temperature lower than the auto-ignition temperature of any surrounding

The following factors are selected depending on the internal free volume of the enclosure and the gas present in the area

- Type of seal (cylindrical, flat, threaded)
- Seal length
- Gap length

The power and temperature control circuits can be accommodated in separate housings.



Type of protection “e” increased safety

Basic principle: Applicable only to material or its components that in normal circumstances do not generate sparks or electric arcs, cannot reach dangerous temperatures, and whose supply voltage does not exceed 1 kV.

Method: To prevent the occurrence of any accidental ignition source (electric arcs, heating)..

This mode of protection is achieved by:

- Selecting high-quality insulating material
- Defining the right creepage distances
- Ensuring the quality of electrical connection
- For all classes of gases and vapours
- Suitable for connection housings

HOT-AIR CONVECTORS, FAW RANGE

The 'FAW' range of hot-air convectorors was designed to heat small working areas, storage areas, or similar applications, located in hazardous areas classed as Zone 1 or Zone 2, where the flammable atmosphere is Gas Group IIA, IIB, or IIC.

Common applications

- Aircraft hangers
- Chemical plants
- Oil platforms
- Petrol service stations
- Gas facilities

General characteristics

- LCIE Certificate ATEX Ex II 2 G EEx'e' IIC T2 to T4, in accordance with EN 50014 and EN 50019
- Terminal box with damp protection grade IP66 / IP67
- Available for temperature classification T2, T3, and T4.
- Ambient temperature range from -20 °C to +60 °C. • Treated-steel or stainless-steel chassis.
- **Terminal box:** Aluminium box with Ø20 mm input for cables. Additional cable inputs will be implemented on request.
- **Heating components:** Tubular elements with fins that can be replaced individually, fabricated with NiCr 80/20 alloy resistive wire, compacted magnesium oxide, and tubular stainless-steel sleeve.
- **Controls:** If necessary, FAW hot-air convectorors can be controlled by remote temperature thermostats for use in classified zones.
- **Assembly:** Valid for floors and walls (wall brackets not included. These must be ordered separately)
- **Power supply:** standard voltages ~240 V single-phase or 3~415 V three-phase.

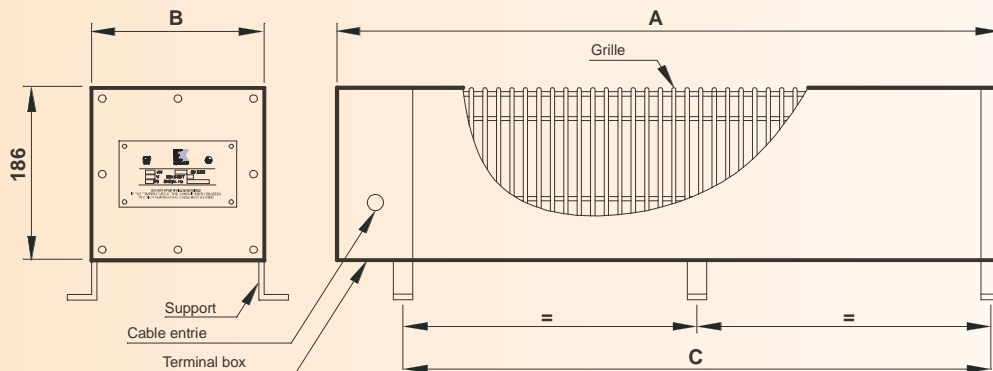
Standard FAW models
Compact range. Stainless-steel chassis

Thermal Class T3 → maximum ambient temperature: 40 °C

Code	Thermal class	Volts	Watts	Nº rods	Dimensions in mm			Weight in kg
					A	B	C	
FAW-C-250-T3	T3	~240	250	2	350	160	282	5
FAW-C-500-T3	T3	~240	500	4	350	160	282	6
FAW-C-750-T3	T3	~240	750	4	615	160	545	6
FAW-C-1000-T3	T3	~240	1000	4	615	160	545	9

Steel chassis.

Thermal Class T4 → maximum ambient temperature: 40 °C

Code	Volts	Watts	Nº rods	Dimensions in mm		
				A	B	C
FAW-250-T4	~240	250	1	1886	160	1785
FAW-500-T4	~240	500	2	1886	160	1785
FAW-750-T4	3~240 Δ 3~415 A	750	3	1886	160	1785
FAW-1000-T4	~240	1000	4	1886	272	1785
FAW-1250-T4	~240	1250	5	1886	272	1785
FAW-1500-T4	3~240 Δ 3~415 A	1500	6	1886	272	1785

Steel chassis.

Thermal Class T2 → maximum ambient temperature: 60 °C

Thermal Class T3 → maximum ambient temperature: 40 °C

Code	Volts	Watts	Nº rods	Dimensions in mm		
				A	B	C
FAW-250-Tx	~240	250	1	971	160	860
FAW-500-Tx	~240	500	2	971	160	860
FAW-750-Tx	3~240 Δ 3~415 A	750	3	971	160	860
FAW-1000-Tx	3~240 Δ 3~415 A	1000	3	1221	160	1120
FAW-1500-Tx	3~240 Δ 3~415 A	1500	3	1741	160	1640
FAW-2000-Tx	~240	2000	4	1741	272	1640
FAW-2500-Tx	~240	2500	5	1741	272	1640
FAW-3000-Tx	3~240 Δ 3~415 A	3000	6	1741	272	1640

Stainless-steel chassis.

Thermal Class T4 → maximum ambient temperature: 40 °C

Code	Volts	Watts	Nº rods	Dimensions in mm		
				A	B	C
FAW-250-S-T4	~240	250	1	1886	160	1785
FAW-500-S-T4	~240	500	2	1886	160	1785
FAW-750-S-T4	3~240 Δ 3~415 A	750	3	1886	160	1785
FAW-1000-S-T4	~240	1000	4	1886	272	1785
FAW-1500-S-T4	3~240 Δ 3~415 A	1500	6	1886	272	1785

Stainless-steel chassis.

Thermal Class T2 → maximum ambient temperature: 60 °C

Thermal Class T3 → maximum ambient temperature: 40 °C

Code	Volts	Watts	Nº rods	Dimensions in mm		
				A	B	C
FAW-250-S-T2	~240	250	1	971	160	860
FAW-500-S-T2	~240	500	2	971	160	860
FAW-750-S-Tx	3~240 Δ 3~415 A	750	3	971	160	860
FAW-1000-S-Tx	3~240 Δ 3~415 A	1000	3	1221	160	1120
FAW-1500-S-Tx	3~240 Δ 3~415 A	1500	3	1741	160	1640
FAW-2000-S-Tx	~240	2000	4	1741	272	1640
FAW-2500-S-Tx	~240	2500	5	1741	272	1640
FAW-3000-S-Tx	3~240 Δ 3~415 A	3000	6	1741	272	1640





ELECTRIC AIR HEATERS, FUH RANGE

Descripción

The FUH range of flame proof electric unit air heaters offer a Hazardous Area, space heating solution, for large premises requiring high heating capacity. They are certified for use in Zone 1 and Zone 2 areas where the flammable atmosphere is a Group IIA, IIB or IIC Gas

Typical Applications

- Oil Refineries
- Petrochemical Plant
- Coal Mines
- Offshore Platforms
- Ammunition Stores
- Sewage Plants
- Paint Stores

General characteristics

- Efficient liquid to air heat exchanger
- Over-temperature protection
- Adjustable angle outlet louvres.
- Optional, integral room temperature control thermostat.
- **Certification:** Certificado ATEX EEx"d" IIC T3, según EN 50014 y EN 50018
- **Heating elements:** Rod type heating elements comprising 80/20 Nickel chrome resistance wire, compacted high purity Magnesium Oxide insulating powder and encased in Incoloy 825 metal sheath.
- **Controls:** Liquid temperature control thermostat. Liquid temperature, manual reset, safety thermostat. Optional: Return air temperature control thermostat
- **Voltage:** Heater and Motor - Standard 3 phase (4 wire) supplies, with possibility of connecting from 3N-380 V to 3N-480 V. In the attached picture the powers corresponding to the assigned voltages. Controls - Up to 240v single phase

Standard models

Model	Heating power according to supply					Air flow (m³/h)	Weight in Kg
	3N~380 V	3N~400 V	3N~415 V	3N~440 V	3N~480 V		
FUH9	7 kW	8,25 kW	9 kW	10 kW	12 kW	1188	120
FUH12	10 kW	11 kW	12 kW	13 kW	16 kW	2463	120
FUH15	13 kW	13,75 kW	15 kW	17 kW	20 kW	2463	145
FUH20	17 kW	18,4 kW	20 kW	23 kW	27 kW	5096	145
FUH30	25 kW	27,5 kW	30 kW	--	--	5096	145

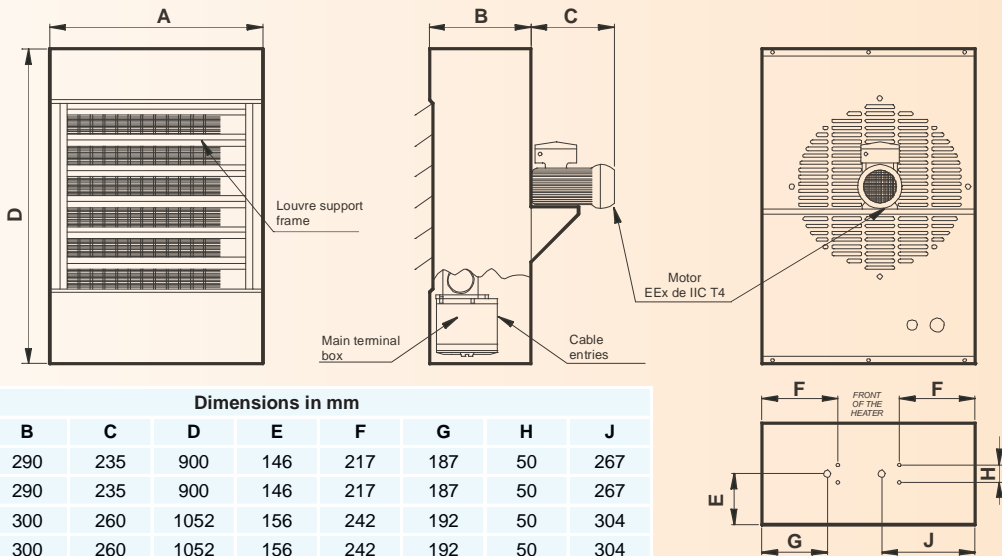

Model	Dimensions in mm								
	A	B	C	D	E	F	G	H	J
FUH9	610	290	235	900	146	217	187	50	267
FUH12	610	290	235	900	146	217	187	50	267
FUH15	760	300	260	1052	156	242	192	50	304
FUH20	760	300	260	1052	156	242	192	50	304
FUH30	760	300	260	1052	156	242	192	50	304

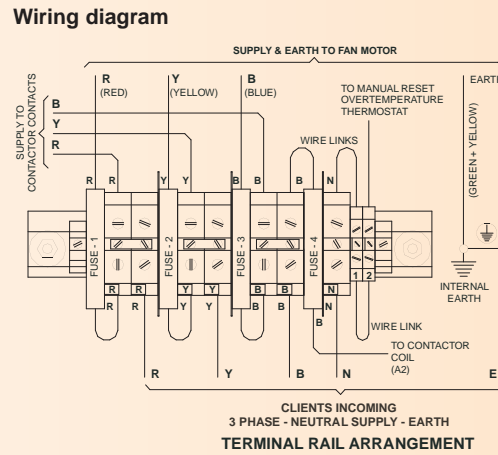
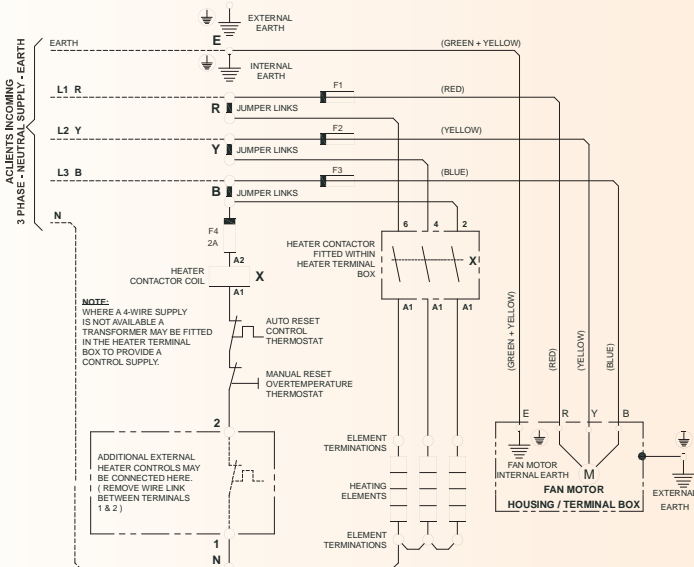

STRAIGHT ANNEALED ELEMENTS ADAPTABLE FOR EVAPORATORS OR TRAY DEFROSTING, RRFI RANGE

Technical data RRFI range

- Stainless steel tube AISI 321 or AISI 304L ANNEALED of Ø8 mm.
- Vulcanized hoods Ø8*7 mm.
- Degree protection against moisture IP67.
- Connection cable HAR H05S-K 1,5 mm² with 500 mm long.
- Standard voltage: ~230 V

Particular characteristics RRFI3'9E model

- Stainless steel tube AISI 321 NOT ANNEALED of Ø8 mm.
- Minimum inner radius of bending 35 mm. See NOTE (1)
- Vulcanized hoods Ø12 mm.
- Degree protection against moisture IP67.
- Connection cable HAR H05S-K 1,5 mm² with 500 mm long + earth connection.
- Standard voltage: ~230 V



Usual applications

- Industrial cooling
- Evaporators
- Melting of snow and ice on rinks
- Cold-storage chambers
- Display cases
- Freezer chambers
- Defrosting of cold-storage chambers (joints, doors, trays, drain pipes, demisting, glass, etc.)
- Maintenance of heat in the piping of sanitary hot water installations
- Fluidization of high viscosity liquids
- Heating of pipes and tanks

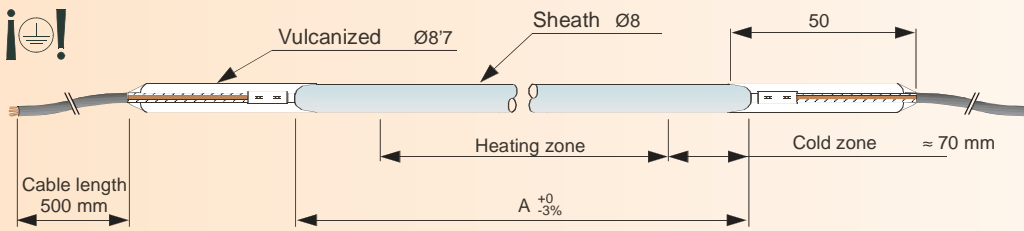

Code	Dimension A in mm	Watts	W/cm ²	Electricfor's construct. thermic class	Weight in Kg
RRFI1	1000	350	1,6	T-600-E	0,25
RRFI1,25	1250	450	1,5	T-600-E	0,31
RRFI1,5	1500	525	1,6	T-600-E	0,37
RRFI1,75	1750	625	1,5	T-600-E	0,43
RRFI2	2000	700	1,5	T-600-E	0,50
RRFI2,25	2250	800	1,5	T-600-E	0,56
RRFI2,5	2500	875	1,5	T-600-E	0,62
RRFI2,75	2750	950	1,5	T-600-E	0,68
RRFI3	3000	1000	1,5	T-600-E	0,74
RRFI3,25	3250	1125	1,4	T-600-E	0,80
RRFI3,5	3500	1250	1,5	T-600-E	0,86
RRFI3,9E	3907	1675	1,77	T-600-E	0,96
RRFI4	4000	1400	1,5	T-600-E	0,98
RRFI4,5	4500	1600	1,5	T-600-E	1,1
RRFI5	5000	1750	1,4	T-600-E	1,2
RRFI5,5	5500	1900	1,4	T-600-E	1,3
RRFI6	6000	2100	1,4	T-600-E	1,5
RRFI6,5	6500	2300	1,4	T-600-E	1,6

This product is supplied in rolls of 0'55 m in diameter to simplify transport, except for models RRFI1, RRFI1'25, RRFI1'5, RRFI1'75 and RRFI3'9E.

NOTE 1

These resistors may be bent to a radius of 15 mm, with the exception of the RRFI3'9E model with minimum inner radius of bending 35 mm.

IMPORTANT: The two ends of the heating area should be kept at a distance of 20 mm from any bend with a radius under 50 mm as indicated Fig. 1

BEND AT ENDS: A length of at least 20 mm should be left free of bends at both ends.

The straight elements manufactured in annealed tube may be bent to obtain the element appropriate to your requirements. Bending can be performed directly at the factory or else you can do it yourself, bearing in mind the limitations stipulated in Fig 1.

Fig. 1

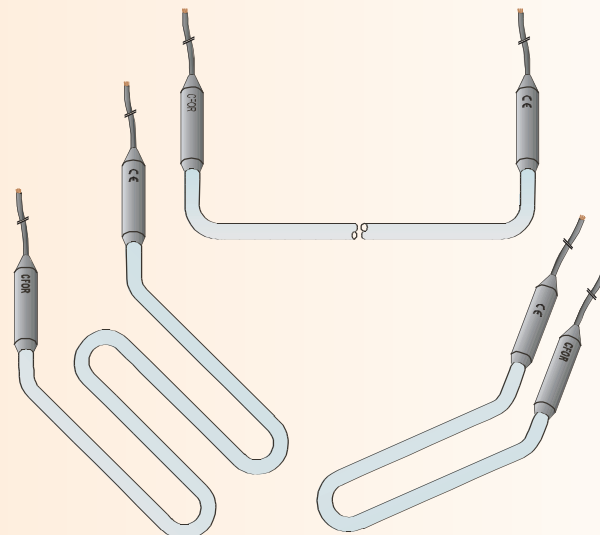
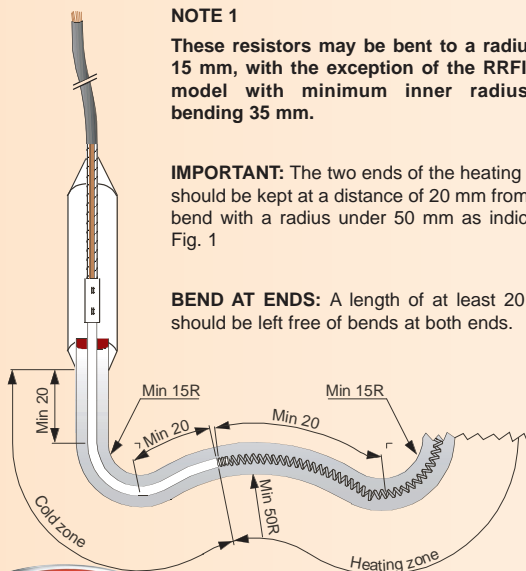



ELEMENTS FOR EVAPORATORS OR TRAY DEFROSTING, EFI RANGE

Technical data EFI range

- Stainless steel tube AISI 321or Incoloy®-825 NOT ANNEALED of Ø8 mm.
- Vulcanized hoods Ø12 mm.
- Degree protection against moisture IP67.
- Connection cable HAR H05S-K 1,5 mm² with 500 mm long + earth connection.
- Standard voltage: ~230 V

Usual applications

- Industrial cooling
- Cold-storage chambers
- Freezer chambers
- Evaporators
- Display cases
- Defrosting of cold-storage chambers

Code	Watts	W/cm ²	Tube material	Shape	Nº drawing	Dimensions in mm		Electricfor's construct. thermic class	Weight in Kg
						L	B		
EF11'67U	1675	1'77	AISI 321	U	1	1929	--	T-550-S	1,14
EF11'8U	1800	1'65	AISI 321	U	1	2224	--	T-550-S	1,31
EF10,7RAC	700	1'1	AISI 321	Straight with elbowed ends	2	2338	174	T-550-S	0,79
EF11,05RAC	1050	1'1	AISI 321	Straight with elbowed ends	2	3588	174	T-550-S	1,16
EF11'67RAC	1675	1'77	AISI 321	Straight with elbowed ends	2	3588	174	T-550-S	1,16
EF10,5UAC	500	1,77	Incoloy® - 825	U elbowed	3	498	144	T-552-S	0,38
EF10,7UAC	700	1'1	AISI 321	U elbowed	3	1155	174	T-550-S	0,78
EF11,05UAC	1050	1'1	AISI 321	U elbowed	3	1780	174	T-550-S	1,15
EF11'67UAC	1675	1'77	AISI 321	U elbowed	3	1780	174	T-550-S	1,15
EF11'8UAC	1800	1'65	AISI 321	U elbowed	3	2063	187	T-550-S	1,33

Drawing nº 1
"U" Shape

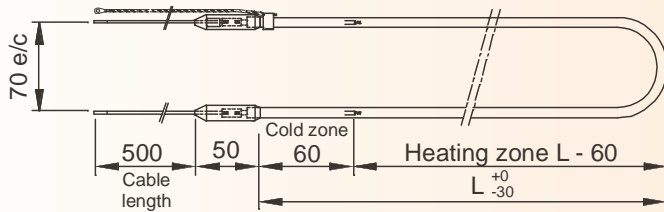

NOTE 1

These elements may be bent to a radius of 35 mm.

IMPORTANT: The two ends of the heating area should be kept at a distance of 20 mm from any bend with a radius under 50 mm as indicated Fig. 1 - pag 49

BENT AT ENDS: A length of at least 20 mm should be left free of bends at both ends.

Drawing nº 2
"Straight with elbowed ends" Shape

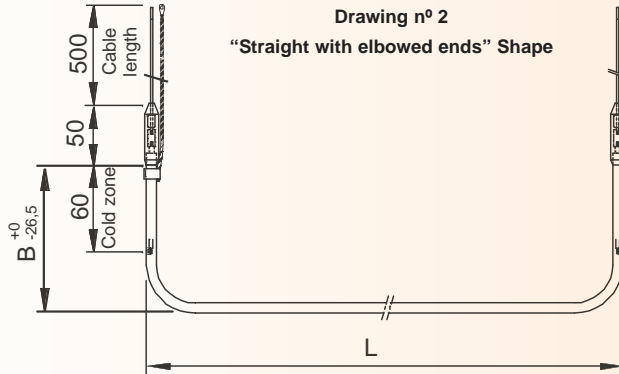

Drawing nº 3
"U elbowed" Shape

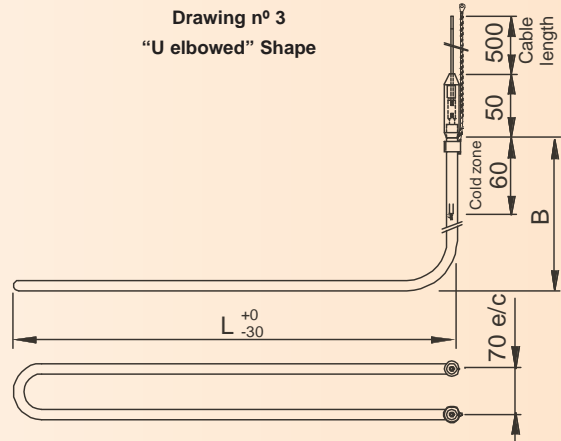

GROUP 4 - Flexible heating elements

FLEXIBLE ANNEALED COPPER HEATING ELEMENTS FOR DRAIN PIPE DEFROSTING, RFIE RANGE

General characteristics

- Copper tube ANNEALED of Ø6'4 or Ø8 mm according to models.
- Vulcanized hoods Ø12 mm.
- Degree protection against moisture IP67.
- Connection cable HAR H05S-K 1,5 mm² with 500 mm long + earth connection.
- Standard voltage: ~230 V

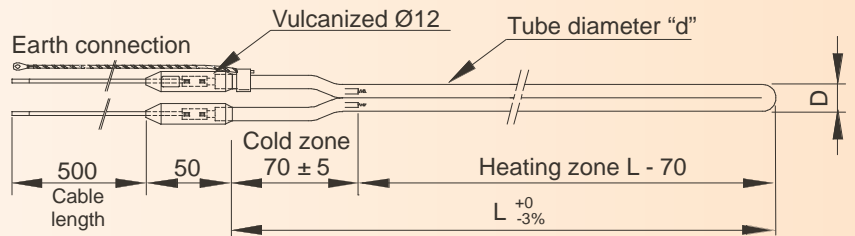

Code	Watts	W/cm ²	Dimensions in mm			Electricfor's constructive thermic class	Weight in Kg
			L	Tube diameter "d"	D		
RFIE1	120	0,3	990	6,4	13	T-175-E	0,37
FFIE1,5	180	0,3	1490	6,4	13	T-175-E	0,53
FRFIE2	350	0,4	1990	6,4	13	T-175-E	0,68
RFIE2,2	400	0,4	2190	8	16	T-175-E	1,1
RFIE2,8	500	0,4	2840	8	16	T-175-E	1,4





FOR-FLEX IN ROLLS OF 150 or 200 METERS

General characteristics

Over 150 different models, between 0,10 Ω /m and 3175 Ω /m.
Request price by Ohm value and roll quantity.

Four types of coating available:

- Silicone \varnothing 3 mm.
- Silicone \varnothing 4 mm
- Fiberglass.
- Silicone + fiberglass.

SFF / SSFF / PSFF / PSSFF

Models as per catalogue: 720 / NTC-8294

GROUP 4 - Flexible heating elements

4.5 - FOR-FLEX silicone heating elements

The insulation of FOR-FLEX flexible heating elements has been achieved by using a silicized compound based on silicone elastomers which moreover provides complete protection of the conductor against moisture and corrosion.

The main feature of this type of element is its flexibility, which makes it adaptable to any type of surface. The minimum radius of curvature of each of the various types is equal to the diameter of the element itself.

The flexible heating elements withstand loads that vary according to the specific needs in each case, between 10 W/m and 50 W/m.

Usual applications

- To heat and maintain temperature of conduction pipes and tanks containing heavy fluids such as combustible oils, greases, paints, waxes and other chemical products.
- Defrosting of refrigerator rooms at a low temperature (joints, doors, trays, waste pipes, glasses, etc.)
- To heat glasses for reactive and distillation appliances.
- To protect against freezing in pipe lines for water and valves
- Prevention of water condensation in connection cabinets

FLEXIBLE SILICONE HEATING ELEMENTS OF \varnothing_{ext} 3 mm, FOR-FLEX NORMAL RANGE

General characteristics

- Approx. \varnothing for all lengths 3 mm.
- Finished with tubular copper-plated terminals and conductor silicone leads 150 mm long.
- Maximum temperature: 180 °C.
- Standard voltage ~230 V
- Other dimensions, voltages and finishes are available on request.

15 W/m Range

Code	Length in mm	W/m	Total watts	Weight in Kg
PSFF1	1000	16,5	16,5	0,010
PSFF1,5	1500	15	22,5	0,014
PSFF2	2000	15	30	0,018
PSFF2,5	2500	17	42,5	0,022
PSFF3	3000	15	45	0,026
PSFF3,5	3500	15	52,5	0,030
PSFF4	4000	15	60	0,034
PSFF4,5	4500	15	67,5	0,038
PSFF5	5000	15	75	0,042
PSFF5,5	5500	15	82,5	0,046
PSFF6	6000	15	90	0,054
PSFF7	7000	15	105	0,062
PSFF8	8000	15	120	0,070
PSFF9	9000	15	135	0,078
PSFF10	10000	15	150	0,086
PSFF12	12000	15	180	0,10
PSFF15	15000	15	225	0,13
PSFF20	20000	15	300	0,20

30 W/m Range

Code	Length in mm	W/m	Total Watts	Weight in Kg
SFF1,5	1500	30	45	0,014
SFF2	2000	30	60	0,018
SFF2,5	2500	30	75	0,022
SFF3	3000	30	90	0,026
SFF3,5	3500	30	105	0,030
SFF4	4000	30	120	0,034
SFF4,5	4500	30	135	0,038
SFF5	5000	30	150	0,042
SFF5,5	5500	30	165	0,046
SFF6	6000	30	180	0,054
SFF7	7000	30	210	0,062
SFF8	8000	30	240	0,070
SFF9	9000	30	270	0,078
SFF10	10000	30	300	0,086
SFF12	12000	30	360	0,10
SFF15	15000	30	450	0,13
SFF20	20000	30	600	0,20

FLEXIBLE SILICONE HEATING ELEMENTS OF \varnothing_{ext} 4 mm, FOR-FLEX SÚPER RANGE

General characteristics

- Approx. \varnothing for all lengths 4 mm.
- Better insulation, less charge and stronger than the normal one.
- Finished with tubular copper-plated terminals and conductor silicone leads 150 mm long
- Maximum temperature: 180 °C.
- Standard voltage ~230 V
- Other dimensions, voltages and finishes are available on request.

15 W/m Range

Code	Length in mm	W/m	Total Watts	Weight in Kg
PSSFF1,5	1500	15	22,5	0,033
PSSFF3	3000	15	45	0,066
PSSFF3,5	3500	15	52,5	0,077
PSSFF4,5	4500	15	67,5	0,10
PSSFF6	6000	15	90	0,13
PSSFF7	7000	15	105	0,15
PSSFF8	8000	14	115	0,17
PSSFF9	9000	15	135	0,19
PSSFF10	10000	15	150	0,21
PSSFF12	12000	15	180	0,25
PSSFF15	15000	15	225	0,31
PSSFF20	20000	15	300	0,42

32 W/m to 36 W/m Ranges

Code	Length in mm	W/m	Total Watts	Weight in Kg
SSFF1	1000	35	35	0,020
SSFF1,5	1500	35	53	0,030
SSFF2	2000	35	70	0,040
SSFF2,5	2500	32	80	0,050
SSFF3	3000	35	105	0,060
SSFF4	4000	35	138	0,080
SSFF4,5	4500	35	157	0,095
SSFF5	5000	36	181	0,11
SSFF6	6000	35	210	0,13
SSFF7	7000	32	224	0,15
SSFF8	8000	35	276	0,17
SSFF9	9000	35	316	0,19
SSFF10	10000	34	341	0,21
SSFF12	12000	35	424	0,25
SSFF15	15000	35	526	0,31
SSFF20	20000	35	696	0,42



Normal applications

- Heating conduction pipes and tanks, containing heavy fluids such as combustible oils, grease, paint, wax and other chemical products
- Defrosting in chambers: joins, doors, trays, waste pipes, anti-mist, windows, etc.
- Heating of glasses for reactives and distillation equipment.
- Protection against freezing in water conduction pipes and valves
- To prevent formation of condensation and water in connection boards.
- To keep farming land on a small scale at a certain temperature.
- Installations for floor heating in premises designed for housing animals (farms, sheds, etc)
- Heating meshes.

FLEXIBLE SILICONE + FIBRE GLASS HEATING ELEMENTS OF $\varnothing_{ext}2.7$ mm, RANGE FORMEC-FLEX

General characteristics

- Approximate diameter for all lengths 2.7 mm.
- Flexible sheath composed of a layer of silicone + extra fibre glass layer. The presence of an additional fibre glass layer lends greater mechanical resistance to the element, reducing the risks of the element breaking due to the silicone being knocked or cut.
- General length tolerance: $\pm 1\%$
- Finished with coppered tubular connector and silicone conductor leads 150mm long
- Maximum temperature of the element: 180 °C.
- Standardised voltage ~230 V
- To order, other lengths, finishes and voltages.



10 W/m Range

Code	Length in mm	W/m	Total watts	Weight in Kg
PPVSFF2	2000	10	20	0,011
PPVSFF2,5	2500	10	25	0,016
PPVSFF3	3000	10	30	0,022
PPVSFF3,5	3500	10	35	0,028
PPVSFF4	4000	10	40	0,034
PPVSFF4,5	4500	10	45	0,040
PPVSFF5	5000	10	50	0,046
PPVSFF5,5	5500	10	55	0,052
PPVSFF6	6000	10	60	0,058
PPVSFF8	8000	10	80	0,064
PPVSFF9	9000	10	90	0,070
PPVSFF10	10000	10	100	0,076
PPVSFF15	15000	10	150	0,12

14 W/m to 17 W/m Ranges

Code	Length in mm	W/m	Total Watts	Weight in Kg
PVSFF1	1000	17	16,5	0,006
PVSFF1,5	1500	15	22,5	0,012
PVSFF2	2000	17	33	0,018
PVSFF2,5	2500	15	37	0,024
PVSFF3	3000	15	46	0,030
PVSFF3,5	3500	14	50	0,036
PVSFF4	4000	14	57,5	0,042
PVSFF4,5	4500	14	64	0,048
PVSFF5	5000	14	71	0,054
PVSFF5,5	5500	14	77	0,060
PVSFF6	6000	15	92	0,066
PVSFF7	7000	15	105	0,078
PVSFF8	8000	15	122	0,090
PVSFF9	9000	16	140	0,10
PVSFF10	10000	17	170	0,11
PVSFF12	12000	15	184	0,13

GROUP 4 - Flexible heating elements

FLEXIBLE FIBRE GLASS HEATING ELEMENTS OF $\varnothing_{ext}2.8$ mm, GAMA VFF



General characteristics

- Approximate diameter for all lengths 2.8 mm.
- Finished with stainless steel tubular connector and fibre glass and nickel conductor leads 150mm long
- Maximum temperature of the element: 350 °C.
- General length tolerance: $\pm 1\%$
- Standardised voltage ~230 V.
- To order, other lengths, finishes and voltages.

Code	Length in mm	W/m	Total Watts	Weight in Kg
VFF1	1000	46	46	0,016
VFF1,5	1500	78	117	0,024
PVFF1,5	1500	20	30	0,024
VFF2	2000	44	88	0,032
VFF2,5	2500	144	360	0,040
PVFF2,5	2500	28	70	0,040
VFF3	3000	100	300	0,048
VFF3,5	3500	73	256	0,056
VFF4	4000	56	224	0,064
VFF4,5	4500	44	198	0,072
VFF5	5000	36	180	0,080
VFF5,5	5500	30	165	0,088
VFF6	6000	25	150	0,096

GROUP 4 - Flexible heating elements

Reptiles are cold blooded animals that depend on the heat of the atmosphere to survive. Each species has its own specific needs, and it is a vital factor for survival of these creatures in captivity. The main objective of regulating the heat of a terrarium is to respond to the needs of the animals which will inhabit it, so we must design the appropriate equipment to satisfy the needs of each animal.

In order to obtain a heat gradient in a terrarium, a hot zone and a cool zone has to be created so that they can adjust their internal temperature depending on their needs by moving from one area to another.

This is achieved by placing thermal cable over a third of the surface of the terrarium.



General characteristics

- Silicone insulation. Approximate diameter for all lengths $\varnothing 5$ mm.
- Vulcanised cap $\varnothing 9 \times 30$ mm at one end.
- Finished with two-pole connection pin
- Standardised voltage ~230 V.
- To order in other lengths, finishes and voltages.

Code	Dimensions in mm			Volts	Total Watts
	Total length	Heating length	Inactive zone		
CFR001	3260	3330	930	~ 230 V	15
CFR002	4260	4930	930	~ 230 V	25
CFR003	5860	2330	930	~ 230 V	50

PARALLEL CONSTANT POWER-OUTPUT CABLE PER METRE HEATING CABLE, CCP MODELS

Parallel-type heating cables have a constant power output per linear metre regardless of their length. It is therefore possible for them to be supplied in coils, as they can be cut and finished on site. They are characterised by the fact that the heating element is coiled around the two insulated cable conductors, with which it has alternating contact at given points. Internally, the cable forms of system of many resistors, in parallel, powered by the two conductors.

Cutting the cable between two contact points will leave two cold non-heating zones, one at each end of the heating-cable section section between the cutting point and the first contact at each end. The cut sections for the CCP parallel cable are of 600 mm.

When applying voltage to the conductors, the heating element receives the voltage between the two contact points. This ensures that the power output per linear metre of the cable is not affected by its length.

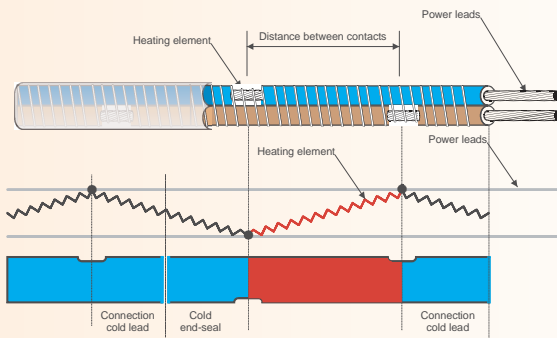

Common applications

- Heating of pipes and tanks containing heavy fluids such as combustible oils, grease, paint, wax, and other chemical products.
- Room defrosting: seals, doors, trays, drainage pipes, demisting, glass, etc.
- Heating of glassware for reagents and distillation apparatus.
- Protection from freezing of water pipes and valves
- Prevention of water condensation in terminal cabinets.

General Characteristics

- Silicone elastomer-based siliconised compound
- External dimensions: 7.5 x 5 mm
- Colour of external covering: Transparent
- Power leads: Nickel-plated copper 2 x 1.5 mm²
- Heating elements: Nickel-Chromium alloy
- Distance between contacts (cut section length): 600 mm
- Maximum exposure temperature (disconnected cable): 180 °C
- Maximum circuit length according to model
- Single-phase power supply ~230 V
- If you wish, we are able to supply other power levels and supply voltages, etc. on request.

Standard models and accessories

Model	W/m	External mesh for earth connection	Colour	Dimensions in mm	Cut section	Maximum section length	Maximum surface temperature		Coil length
							Under voltage (1)	No voltage(2)	
CCP20T	20	NO	TRANSPARENT	7,5 x 5 mm	1000 mm	105 m	130 °C	180 °C	200 m
CCP30A	30	NO	TRANSPARENT	7,5 x 5 mm	600 mm	90 m	115 °C	180 °C	150 m
CCP30AM	30	YES	---	8,5 X 6 mm	600 mm	90 M	115 °C	180 °C	150 m
CCP40T	40	NO	TRANSPARENT	7,5 x 5 mm	600 mm	80 m	100 °C	180 °C	200 m

(1) Maximum temperature with cable connected to the the mains
 (2) ximum temperature with cable disconnected

Code	Description	Reference
525009000	Shrink-wrap kit WITHOUT earth connection Damp protection grade IP65	CAB21

TORPEDO-TYPE TWO-POLE SILICONE RESISTORS, RBS MODELS

Two-pole silicone resistors are flexible resistors with ext. Ø 4.5 mm silicone insulation. They are called torpedo type because one of the ends is finished in the form of a torpedo-shaped sheath. The other end is connected to power via its faston terminals.

General Characteristics

- Silicone elastomer-based siliconised compound
- External dimensions: Ø4.5 mm
- Colour of external covering: White
- Power leads: 2 x 1.5 mm² 500-mm long nickel-plated copper
- Faston-type connection terminals.
- Heating elements: Nickel-Chromium alloy
- Maximum exposure temperature (disconnected cable): 180 °C
- Single-phase power supply ~230 V
- If you wish, we are able to supply other power levels and supply voltages, etc. on request.



Common applications

- Deicing and frost prevention on roofs, gutters, and water downspouts, etc.
- Room defrosting: seals, doors, trays, drainage pipes, demisting, glass, etc.
- Agricultural applications such as aquariums, terrariums, and small water tanks.

Standardised models

Code	Length in mm	W/m	Total Watts	Weight in Kg
RBS1	1000	15	15	0,066
RBS2	2000	15	30	0,085
RBS3	3000	15	45	0,12
RBS4	4000	15	60	0,15
RBS4,5	4500	15	67,5	0,16
RBS5	5000	15	75	0,18
RBS5,5	5500	15	82,5	0,21
RBS6	6000	15	90	0,22
RBS7	7000	15	105	0,23
RBS8	8000	15	120	0,24
RBS9	9000	15	135	0,32
RBS10	10000	15	150	0,40
RBS12	12000	15	180	0,45
RBS15	15000	15	225	0,56
RBS20	20000	15	300	0,65



HEATING HOSES, MODELS ELH

Heating hoses are the ideal solution for flexible transportation of liquids or gases without heat loss. The necessary temperature, wattage, application, and type of outer protective material determine the choice of the most suitable heating hose.

Standard heated hoses are available for temperatures up to 250°C and a range of pressure from 500 bar (it depends on the diameter). Heated hoses over 250°C are available on request.

In analysis techniques, gaseous substances driven from the measuring point to the analysing instrument must be protected against cooling, condensation, or guaranteeing constant temperatures up to 250°C (for example, in refineries, the chemical industry, engine smoke analysis, etc).



General applications

- To keep a product in a fluid state during its processing
- Maintaining liquids or gases at a specific working temperature
- To optimise their characteristics for processing
- To prevent condensation in gaseous mediums
- To process products in a cheaper way
- To guarantee constant quality
- To guarantee mobility of the production or measuring equipment
- Transportation of gas samples from a measuring point to an analyser
- For connecting mobile groups and equipment

Examples of applications

- In polyurethane foam rubber production plants
- In wax production installations
- In asphalt and bitumen projection and application equipment
- In gluing machines that work with cold glue (labellers)
- In installations of hot glue application and their equipment (hotmelt)
- In heavy oil ducts
- In gas analysis instruments
- In food product processing installations, etc.

Standardised models Pressure/ Heating up to 250 °C. Types ELH-MD, ELH-HD and ELH-SHD

ELH heating hoses are used to maintain the temperature and transportation of substances without heat losses

General Characteristics

Heating power	Up to 310 W/m (higher power upon request)
Maximum length	0,3 m up to 60 m
Nominal diameter	DN4 up to DN25
Operation temperature	Up to 250 °C (higher temperatures upon request)
Operating pressure	80 bar (T1 - DN25) 500 bar (T3 – DN6)
Nominal voltage	12 V – 24 V – 110 V – 230 V – 400 V
Temperature sensor	PT 100, Thermo couple

Constructive options

Inner hose	PTFE with stainless steelbraiding single= T1, double=T2, triple=T3
Fittings	Steel bichromate coated Stainless steel
Outer Sheath	PA corrugated PU spirally wound corrugated Polyamide braiding Galvanized steel braiding Stainless steel (AISI 303)
End Cap	Silicone EPDM without silicone Plastic Metal
Cable exit	Lateral to the front Led back Front side Under end cap led back Lateral
Glands	Combinations Fixed glands Moveable glands

Pressure work for work temperatures between +20 °C and +50 °C

	DN							
	4	6	8	10	13	16	20	25
ELH-MD	275	240	200	175	150	135	100	80
ELH-HD	---	275	250	225	200	175	150	130
ELH-SHD	---	500	475	475	450	363	275	225

Normalised heating power at 230 V or 400 V

	DN							
	4	6	8	10	13	16	20	25
Heating power at 100 °C (W/m)	85	100	110	135	160	180	210	240
Maximum length (m)	60	55	50	40	35	30	25	20
Heating power at 200 °C (W/m)	110	120	130	150	180	225	260	290
Maximum length (m)	50	45	40	35	30	23	20	18
Heating power at 250 °C (W/m)	110	130	150	180	210	240	270	310
Maximum length (m)	45	40	35	30	25	20	18	16

Constructive detail of an ELH heating hose

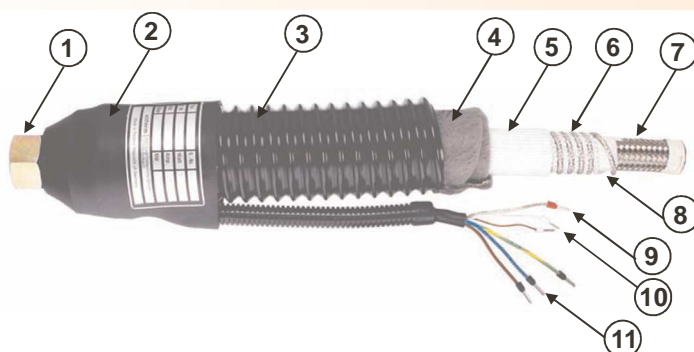

- 1 Coupling
- 2 End cap
- 3 Outer sheath
- 4+5 Insulation
- 6 Heating lead with PTFE insulation
- 7 Inside hose with single, double or triple pressure layer
- 8 Spacer
- 9 Temperature sensor
- 10 Additional leads
- 11 Mains leads



SFFM

Models as per catalogue: NTC-9702

GROUP 4 - Flexible heating elements

4.12 - Silicone heating wire covered with tinned copper mesh

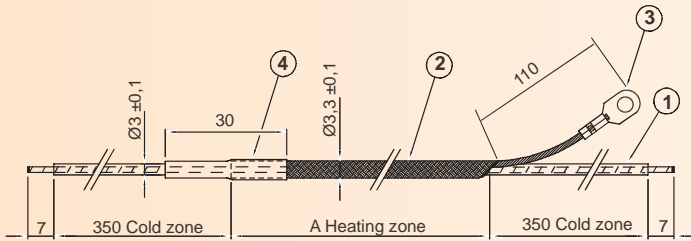

Heating wire with insulating coating in silicone rubber $\varnothing 3$ mm ext. Its innovative manufacturing system allows replacement of the traditional cables by incorporated terminal of 350 mm (1). The flexible heating element is delivered with the two ends inactive in order to make easier connection to the network.

The heating wire is 100% covered (of its active length) with a tinned copper mesh (2) that acts as earth connection. The mesh is joined to the silicone cable at one of its active ends by a shrink-fit (4) and ends up on the other side through a plaiting of the mesh with a crimped fork terminal (3).

General characteristics

- Approx. \varnothing for all lengths 3,3 mm.
- Tinned copper mesh for continuous protection and earth connection
- Maximum temperature: 180 °C.
- Standard voltage ~230 V
- Other dimensions, voltages and finishes are available on request



Code	Heating length. Dim A in mm	W/m	Total Watts	Weight in Kg
SFFM3,5	3500	24	84	0,09
SFFM5,5	5500	22,2	123	0,12
SFFM7,5	7500	20,5	154	0,17
SFFM11	11000	22,2	245	0,25

FFC

Models as per catalogue: NTC-9702

GROUP 4 - Flexible heating elements

4.13 - Flexible annealed copper tubing heating element for pipes



General characteristics

- Tubular element in annealed copper tube of $\varnothing 6,4$ mm, insulated with electromelted and lamination-compressed magnesium oxide
- Power: 125 W/m.
- Non heating zone: 110 mm.
- Finished with silicone hood and cable on both sides. (Length of cables 300 mm.)
- Standard voltage: ~230 V.

These resistors may be bent to a radius of 11 mm,

IMPORTANT: The two ends of the heating area should be kept at a distance of 10 mm from any bend with a radius under 50 mm as indicated Fig. 1

BEND AT ENDS: A length of at least 20 mm should be left free of bends at both ends.

Code	Length in mm	Total Watts	Electricfor's constructive thermic class	Weight in Kg
FFC1	1000	125	T-175-E	0,20
FFC2	2000	250	T-175-E	0,40
FFC3	3000	375	T-175-E	0,60
FFC4	4000	500	T-175-E	0,80

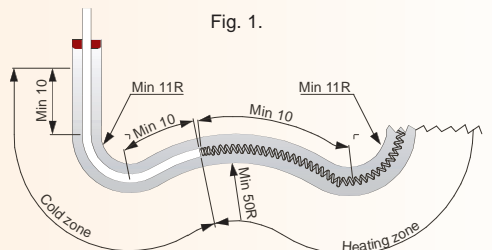

CFF

GROUP 4 - Flexible heating elements

4.14 - Heating elements for compressors

HEATING ELEMENTS FOR COMPRESSORS, CFF RANGE

Adaptable to any type of compressor, boilers, tanks, etc. whether circular or oval. The range of heating elements for fridge compressor carters prevents the oil from absorbing part of the refrigerant liquid of the compressor. They are adaptable to any type of compressor, boiler or tank, whether cylindrical or oval.

Providing heat is fundamental for complete and rapid absorption. The higher the temperature, the greater and quicker the absorption. In addition, at the moment of starting up, if the temperature is low, the compressor can be severely damaged owing to the lack of lubrication.

CFF heating elements provide the necessary heat for guaranteeing that the process in the carter is carried out with the greatest efficiency and speed, lengthening the life of the inside components.

General characteristics

- Heating element protected with tin-plated copper woven mesh.
- 2-wire silicone hose cable + Earth of 0.75 mm², 1000mm long.
- Minimum insulation: 100 M Ω (at 2500 V)
- Tolerance with power: $\pm 10\%$
- Standardised voltage ~230 V

Standard models

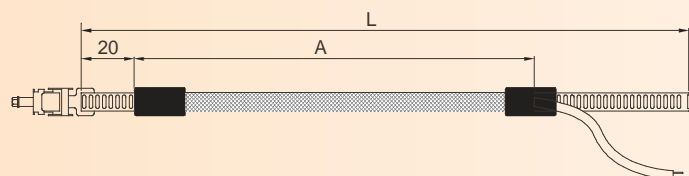

Code	Watts	Dimensions in mm				Weight in Kg
		A	L	\varnothing minimum compressor	\varnothing maximum compressor	
CFF300	45 W	300	500	$\varnothing 100$	$\varnothing 150$	0,14
CFF350	35 W	350	550	$\varnothing 120$	$\varnothing 170$	0,15
CFF450	45 W	450	750	$\varnothing 150$	$\varnothing 230$	0,17
CFF500	60 W	500	1000	$\varnothing 165$	$\varnothing 310$	0,20
CFF550	55 W	550	900	$\varnothing 180$	$\varnothing 280$	0,18
CFF750	65 W	750	1050	$\varnothing 245$	$\varnothing 330$	0,19



SILICONE HEATER MATS, CUSTOMIZE MANUFACTURE

Wire wound silicone rubber heaters are available from one off to large batch quantity with almost no limit to design variations to satisfy customer specification. A high quality product at competitive prices coupled with fast delivery times all backed up by a full design and technical service to meet our customers' stringent requirements

All heater mats are manufactured to conform to the EEC Low Voltage and EMC Directives and are CE marked accordingly.

Silicone rubber because of its high temperature tolerance and superb electrical insulating properties is well suited to the production of heater mats. Holroyd heater mats are produced by laminating the evenly spaced resistance wires between two sheets of silicone rubber, reinforced with a glass textile to give improved mechanical strength.

These surface heaters are suitable for applications where precise heating is required. Fine resistance wires accurately and precisely positioned over areas of almost any shape or size. The close even spacing of the wires ensure a uniform heat distribution over the entire working area. The maximum continuous operating temperature for a silicone rubber heater mat is 200°C, allowing for a generous safety margin for short term over-temperature excursions as high as 230°C. Being thin and light weight, silicone rubber heater mats have a low thermal mass and therefore have rapid heat up characteristics and a fast response to temperature control



Heater mats can be manufactured in almost any size and shape to suit the application, including holes and cut outs without disturbing the even distribution of heat. Also available is a range of in-built temperature limiters or temperature sensors to suit customer's instrumentation.

Heater mats can be supplied with an acrylic self-adhesive backing to allow for easy positioning and assembly. A separate silicone adhesive system is available if required.



These heaters can also be manufactured with eyelets, straps, hooks or Velcro as further options for fixing.

Another manufacturing option for the heater mats is pre-formed elements, with a thicker silicone layer and with a fibreglass layer, ensuring that the element keeps its required cylindrical shape. Suitable for heating and for maintaining temperatures in pipes



Finally, there is the possibility for the heater mats to incorporate a silicone foam insulation layer that minimises heat loss from the system. Available in thicknesses of 4 or 8mm.

SILICONE HEATER MATS, STANDARD MODELS

The etched foil element type is created by acid etching a circuit in resistance alloy foil. This process ensures excellent circuit pattern repeatability and allows the design of complex heat distribution patterns within the heater area.

Etched foil elements are able to operate at very high watt densities, this is due to the large surface area covered by the foil track. The foil track also gives excellent uniformity and faster heat transfer resulting in longer heater life in high power applications. Etched foil heater mats can be manufactured to almost any shape and size to suit customer application. Intricate shapes, holes and cut-outs can be provided without disturbing the even distribution of the heat.

Etched foil elements can be supplied with inbuilt thermal limiters or a variety of temperature sensors to suit customers instrumentation. The BSA heaters present a circular orifice in the center of their surface, where a bimetallic thermostat type PK1 or 1NT can be fit (consults the present Price List page n° 48).

Etched foil heaters are available in three types of insulation;

- **Silicone Rubber:** Has superb electrical insulating properties and a high temperature tolerance. The maximum continuous operating temperature is 200°C with short-term excursions to 230° C.
- **Kapton:** Polyamide is a thin lightweight organic polymer film that provides excellent tensile strength, tear resistance and dimensional stability. Ideal for applications requiring low outgassing or resistance to radiation, chemicals and solvents. Operating temperature range -195° C to +200° C
- **Polyester:** Low cost alternative to silicone rubber and kapton. Polyester is suitable for low temperature applications up to 120° C.

General characteristics

- External insulation material: Silicone rubber reinforced with fiber glass 0,7mm ±0,1 thickness
- Operating temperature to 180°C
- Adhesive 3M 966
- White PTFE connection leads, 500 mm long

Code	Volts	Watts	Dimensions in mm
BSA-100X150	~240	50	100 x 150
BSAB-100X150	~240	100	100 x 150
BSA-150X200	~240	100	150 x 200
BSAB-150X200	~240	200	150 x 200
BSA-200X300	~240	200	200 x 300
BSAB-200X300	~240	400	200 x 300
BSA-200X400	~240	267	200 x 400
BSAB-200X400	~240	533	200 x 400

Code	Volts	Watts	Dimensions in mm
BSA 12V-25x50	12 Vcc	1,25	25x50
BSA 12V-50x50	12 Vcc	2,5	50x50
BSA 12V-50x75	12 Vcc	3,75	50x75
BSA 12V-50x100	12 Vcc	5	50x100
BSA 12V-50x150	12 Vcc	7,5	50x150
BSA 12V-75x100	12 Vcc	7,5	75x100
BSA 12V-75x200	12 Vcc	15	75x200
BSA 12V-100x100	12 Vcc	10	100x100
BSA 12V-100x150	12 Vcc	15	100x150
BSA 12V-150x200	12 Vcc	30	150x200
BSA 12V-200x300	12 Vcc	60	200x300
BSA 12V-200x400	12 Vcc	80	200x400
BSA 12V-D50	12 Vcc	2	Ø 50
BSA 12V-D75	12 Vcc	4	Ø 75
BSA 12V-D100	12 Vcc	8	Ø 100

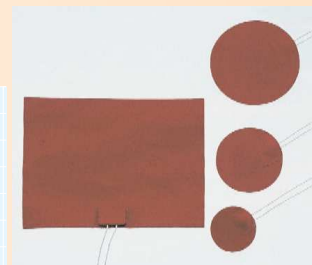

GROUP 4 - Flexible heating elements

4.16 - Flexible heating blankets for curing composites with EASYSeal vacuum technology

- Reusable flexible blanket and vacuum bag
- 2 years guarantee
- High flexibility
- Fast, efficient and uniform in heat production up to 232 °C
- Use on horizontal or vertical surfaces and also on complex surfaces without needing to replace the damage section.
- Compatible with the ACR-II system for temperature and vacuum control (consult our technical department for further information on the subject)



General characteristics

- The vacuum ports eliminate the need for vacuum packing materials.
- The sealing blanket added around the edge eliminate the need for adhesive tape
- Flexibility:
 - With sealing blanket: radius 76 mm
 - Without sealing blanket: radius 6 mm
- Laminated heating element between two non-reinforced layers of silicone rubber.
- Maximum exposure temperature: 232 °C
- Load density: 0.8 W/cm²
- Dielectric rigidity over 2000 V
- Resistant to damp, chemical products and radiation
- Pressure reliever constructed right around the edge of the blanket to increase durability.
- 1800mm long supply lead.
- Supply current: ~240 V ac

Easy installation in 3 steps



1. Prepare the surface to be repaired.
2. Place the vacuum heating blanket immediately on the surface.
3. Optionally add insulation on the blanket and carry out the curing.

Standardised rectangular models

Code	Dimensions In mm		Heating zone		Watts
	Width	Length	Width	Length	
SRV5-240-6X6-S-A	229	305	152	152	180
SRV5-240-6X12-S-A	229	457	152	305	360
SRV5-240-6X24-S-A	229	762	152	610	720
SRV5-240-8X8-S-A	279	356	203	203	320
SRV5-240-10X10-S-A	330	406	254	254	500
SRV5-240-12X12-S-A	381	457	305	305	720
SRV5-240-12X24-S-A	381	762	305	610	1440
SRV5-240-16X16-S-A	483	559	406	406	1280
SRV5-240-18X18-S-A	533	610	457	457	1620
SRV5-240-24X24-S-A	686	762	610	610	2880

Standardised round models

Code	Dimensions In mm		Heating zone		Watts
	Diameter	Diameter	Diameter	Diameter	
SRV5-240-6D-S-A	Ø152	Ø305	Ø305	Ø305	140
SRV5-240-8D-S-A	Ø203	Ø356	Ø356	Ø356	250
SRV5-240-10D-S-A	Ø254	Ø406	Ø406	Ø406	395
SRV5-240-12D-S-A	Ø305	Ø457	Ø457	Ø457	565
SRV5-240-16D-S-A	Ø406	Ø559	Ø559	Ø559	1005
SRV5-240-20D-S-A	Ø508	Ø660	Ø660	Ø660	1570
SRV5-240-24D-S-A	Ø610	Ø762	Ø762	Ø762	2270

FGH / SXH



GROUP 4 - Flexible heating elements

4.17 - Flexible high temperature heating blankets for curing composites

- Designed for working with the new high temperature thermoplastics and polyamides for composites.
- High flexibility, up to 25mm radius
- Compatible with the ACR-II system for temperature and vacuum control (consult our technical department for further information on the subject)

General characteristics

- Heating element with a 25mm layer of high-density fibre glass and covered with abrasion-proof fibre glass cloth (FGH models) or Samox® material (SXH models)
- Maximum exposure temperature
 - FGH models: 425 °C
 - SXH models: 593 °C
- Load density:
 - FGH models: 1.1 W/cm²
 - SXH models: 2.0 W/cm²
- Dielectric rigidity over 2000V
- It requires a high temperature J type thermopar
- 1800mm long supply lead
- Supply current: ~240 Vac

Standardised FGH models (425 °C)

Code	Dimensions in mm		Watts
	Width	Length	
FGH-06x06-2-A	152	152	255
FGH-06x12-2-A	152	305	504
FGH-06x24-2-A	152	610	1008
FGH-08x08-2-A	203	203	448
FGH-10x10-2-A	254	254	700
FGH-12x12-2-A	305	305	1008
FGH-12x24-2-A	305	610	2016
FGH-16x16-2-A	406	406	1792
FGH-18x18-2-A	457	457	2268
FGH-24x24-2-A	610	610	4032

Standardised SXH models (593 °C)

Code	Dimensions in mm		Watts
	Width	Length	
SXH-06x06-2-A	152	152	468
SXH-06x12-2-A	152	305	936
SXH-06x24-2-A	152	610	1872
SXH-08x08-2-A	203	203	832
SXH-10x10-2-A	254	254	1300
SXH-12x12-2-A	305	305	1872
SXH-12x24-2-A	305	610	3744
SXH-16x16-2-A	406	406	3328
SXH-18x18-2-A	457	457	4212





Its working principle is simple: it adapts at all time, for each spot, the dissipated thermal power at the necessary level of temperature and specific needs.

The heating element, inserted between two copper conductors is composed of a polyolefin matrix mixed with a multitude of carbon particles.

These carbon particles ensure the conductivity between the two copper conductors therefore creating an electrical resistance which leads to the heating of cable until the desired temperature (defined by the power of the cable) is reached.

The power absorbed, dissipated in the form of heat, diminishes depending on the temperature until reaching thermic auto-regulation balance.

Due to its properties, the self-regulating heating cable reacts to every temperature change and supplies the required energy in each spot of the system. Furthermore, the absorbed power is practically nil on reaching a determined temperature, avoiding all the problems deriving from over-heating.

Usual applications

- It maintains the temperature of sanitary hot water: The water comes out of the tap hot the minute it is turned on, all possible heat losses having been compensated. Return circuit is avoided.
- Protection against formation of ice on all outside piping.
- Defrosting of eaves and projections.
- It prevents freezing in pipes and sloping roofs.
- It does not allow freezing of fuels, whether liquid or gaseous, inside cisterns or their circulation circuits.
- Surface heating for outside anti-freeze protection: accesses, garage ramps, porches and stairways.

SELF REGULATING HEATING CABLE, ESR, CAB and TRC RANGES

Code	Model	W/m			Earth connection		Colour	Outer layer	Maximum temp .sup.		Length coils
		At 0 °C	At 10 °C	At 65 °C	Mesh 4-A	Alumini um foil + cable 4-B			Under voltage (1)	With out voltage (2)	
525025000	ESR-S	15	12	-	NO	⇒	GREY	NO	65 °C	80 °C	100 m
525022000	CAB/TP-10	11	10	-	YES	-	YELLOW	PVC	40 °C	85 °C	50 m
525030000	TRC-15	17	13	-	-	YES	BLACK	PVC	65 °C	80 °C	100 m
525014000	CAB/T-15	18	15	-	YES	-	BLUE	NO	55 °C	85 °C	50 m
525015000	CAB/TP-15	18	15	-	YES	-	BLUE	PVC	55 °C	85 °C	50 m
525035000	TRC-20	24	20	-	-	YES	BLACK	PVC	65 °C	80 °C	100 m
525018000	CAB/TP-24	28	25	-	YES		RED	PVC	65 °C	85 °C	50 m
525040000	TRC-30	36	30	-	-	YES	BLACK	PVC	65 °C	80 °C	100 m
525045000	TRC-W-55	22,5	23	7,5	-	YES	BLACK	PVC	100 °C	120 °C	100 m
525050000	TRC-W-65	31,5	32	13	-	YES	BLACK	PVC	100 °C	120 °C	100 m
525003003	CAB/TX-19,5	21	21	11	YES	-	BLUE	PF	135 °C	135 °C	50 m

We also emphasize the ESR-S model the major application of which is industrial cold and overall large refrigerator chambers due to its low cost and great quality.

(1) Maximum temperature that the self regulating heating cable is able to maintain, whenever the conditions of work are appropriate (the insulation, diameter of the pipe. For further information, consult the technical notices NTC-0113, NTC-0114 and NTC-0115)

(2) Maximum temperature that the self regulating heating cable is able to support. Above this temperature the self regulating heating cable can be damaged with consequent malfunctioning of the same.

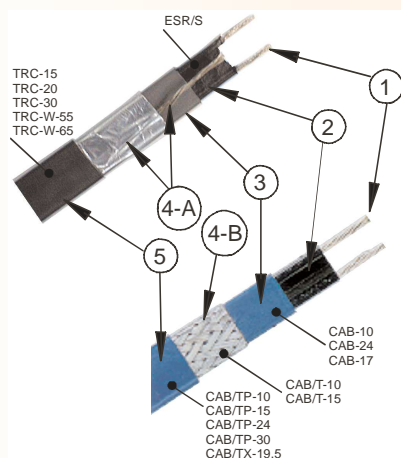

General characteristics

- 1 Tinned copper conductor.
- 2 Heating element with automatic adjustment (Cross-linked carbon plastic).
- 3 Internal protection sheath made of thermo-plastic elastomer
- 4-A Interlaced metallic layer of tinned copper acting as earth connection protector.
- 4-B Surrounding continuous of aluminum foil with tinned copper cable for earth connection
- 5 External protection layer against corrosion, chemicals and environmental factors. It may be composed of Fluorinated polyolefin or Thermoresistant PVC.

Connection accessories for self regulating cable

QUIKSET Range

Code	Description	Reference
525005000	Female connector plug. IP65	CAB02
525006000	Male connector plug. IP65	CAB03
525007000	"T" shunt plug. IP65	CAB04
525009000	Shrink fit kit WITHOUT earth connection. IP65	CAB21
525010000	Shrink fit kit WITH earth connection. IP65	CAB20

DOMOCLICK Range

Code	Description
DHB-100	Power supply connector + 1 Cable output. IP54
DHB-101	In line junction for 2 cables. IP54
DHB-102	Power supply connector + Cable outputs. IP54
DHB-103	"T" Connector for 3 cables. IP54
DHB-104	Power supply connector + 3 Cable outputs. IP54
DHB-400	Shrink fit kit for self regulating cable

Example of assembled self regulating cable with kit CAB21

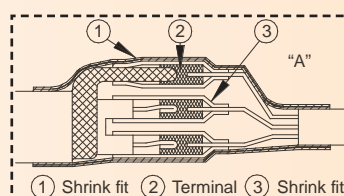
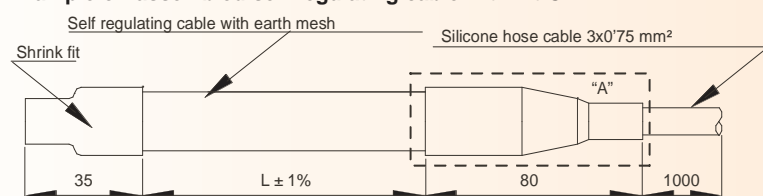

METHOD: Cut the cable to the desired length, insert it 2 cm into a piece of shrink-fit covering of 3,5 cm and apply heat.



LINEAL POWER HEATING BANDS FOR HIGH TEMPERATURE, MODELS ELW

- High flexibility
- Ready to use
- Easy to install
- Does not damage surfaces to which it is applied
- Power supply at one end only
- Minimum curvature radius



Modelos ELW-GNN

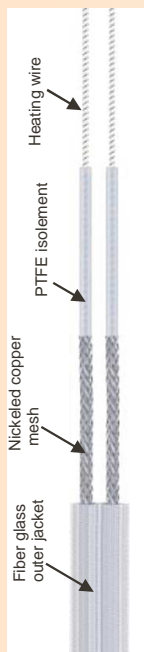

Technical characteristics

- PTFE insulation
- Nickel copped earth mesh
- Fibre glass outer sheath
- Class I protection
- Supply lead 1200mm long
- Dimensions: 25 x 6 mm
- Minimum curvature radius: 10 mm
- Maximum working temperature: +150 °C
- Maximum temperature of the element: +220 °C
- Nominal voltage: ~230 V

Heated length in mm	Code	Nominal output (W) temp. Max. 100 °C	Code	Nominal output (W) temp. Max. 150 °C	Code	Nominal output (W) temp. Max. 200 °C
600	ELW-GN-0,6-001	30	-	-	-	-
1100	ELW-GN-1,1-011	54	-	-	-	-
1700	ELW-GN-1,7-701	78	ELW-GN-1,7-702	52	ELW-GN-1,7-703	24
2400	ELW-GN-2,4-021	94	ELW-GN-2,4-022	69	ELW-GN-2,4-023	37
3000	ELW-GN-3-031	147	ELW-GN-3-032	88	ELW-GN-3-033	44
4200	ELW-GN-4,2-041	210	ELW-GN-4,2-042	126	ELW-GN-4,2-043	63
5400	ELW-GN-5,4-051	245	ELW-GN-5,4-052	163	ELW-GN-5,4-053	82
6000	ELW-GN-6-061	294	ELW-GN-6-062	176	ELW-GN-6-063	88
7000	ELW-GN-7-071	344	-	-	-	-
10000	ELW-GN-10-101	464	ELW-GN-10-102	294	-	-
12500	ELW-GN-12,5-121	623	ELW-GN-12,5-122	371	ELW-GN-12,5-123	192
15000	ELW-GN-15-151	705	ELW-GN-15-152	441	ELW-GN-15-153	220
17500	ELW-GN-17,5-171	864	ELW-GN-17,5-172	521	-	-
21000	ELW-GN-21-211	1008	ELW-GN-21-212	611	ELW-GN-21-213	315
28000	ELW-GN-28-281	1390	ELW-GN-28-282	756	ELW-GN-28-283	378

Models ELW-VA

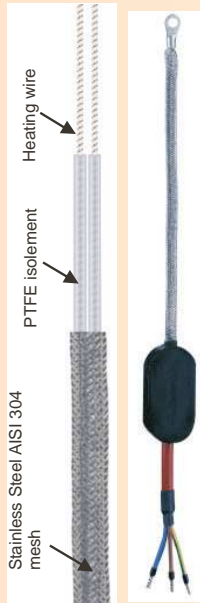

Technical characteristics

- PTFE insulation
- Protective braid: AISI 304 (1.4301)
- Output: approx 50 W/m
- Supply lead 1200mm long, without plug
- Dimensions of band: 10 x 5 mm
- Dimensions of the head (widthxheightxlength): 32 x 16 x 65 mm
- Bending radius, flat, min.: 15 mm
- Installation temperature, min: -30 °C
- Maximum operating temperature: +260 °C
- Nominal voltage: ~230 V
- Class I protection

Heated length in mm	Code	Nominal output (W) temp. Max. 100 °C	Code	Nominal output (W) temp. Max. 150 °C	Code	Nominal output (W) temp. Max. 200 °C
600	ELW-VA-0,6-001	30	-	-	-	-
1100	ELW-VA-1,1-011	54	-	-	-	-
1700	ELW-VA-1,7-701	78	ELW-VA-1,7-702	52	ELW-VA-1,7-703	24
2400	ELW-VA-2,4-021	94	ELW-VA-2,4-022	69	ELW-VA-2,4-023	37
3000	ELW-VA-3-031	147	ELW-VA-3-032	88	ELW-VA-3-033	44
4200	ELW-VA-4,2-041	210	ELW-VA-4,2-042	126	ELW-VA-4,2-043	63
5400	ELW-VA-5,4-051	245	ELW-VA-5,4-052	163	ELW-VA-5,4-053	82
6000	ELW-VA-6-061	294	ELW-VA-6-062	176	ELW-VA-6-063	88
7000	ELW-VA-7-071	344	-	-	-	-
10000	ELW-VA-10-101	464	ELW-VA-10-102	294	-	-
12500	ELW-VA-12,5-121	623	ELW-VA-12,5-122	371	ELW-VA-12,5-123	192
15000	ELW-VA-15-151	705	ELW-VA-15-152	441	ELW-VA-15-153	220
17500	ELW-VA-17,5-171	864	ELW-VA-17,5-172	521	-	-
21000	ELW-VA-21-211	1008	ELW-VA-21-212	611	ELW-VA-21-213	315
28000	ELW-VA-28-281	1390	ELW-VA-28-282	756	ELW-VA-28-283	378

Models ELW-H

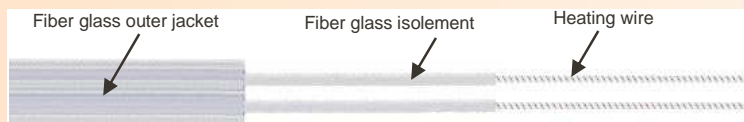

Technical characteristics

- Fibre glass insulation
- Fibre glass outer sheath
- Protection: it depends on the installation
- Supply lead 1200mm long
- Dimensions: 30 x 5 mm
- Minimum curvature radius: 10 mm
- Maximum working temperature (for +250W/m): +450 °C
- Maximum temperature of the element: +500 °C
- Nominal voltage: ~230 V

Code	Heated length in mm	Total Watts
ELW-H-0,5	500	126
ELW-H-0,7	700	180
ELW-H-1	1000	250
ELW-H-1,5	1500	375
ELW-H-2	2000	490
ELW-H-2,5	2500	622
ELW-H-3,25	3250	768
ELW-H-4	4000	987
ELW-H-5	5000	1260
ELW-H-6,3	6300	1555
ELW-H-8	8000	1945



Models ELW-HS



Technical characteristics

- Fibre glass insulation
- Stainless steel AISI 304 earth mesh
- Fibre glass outer cover
- Class I protection
- 1200mm long supply lead
- Dimensions: 30x5mm
- Minimum curvature radius: 10mm
- Maximum working temperature (for ± 250 W/m): +450 °C
- Maximum temperature of the element: +500°C
- Nominal voltage: ~230 V

Code	Heating length in mm	Total Watts
ELW-HS-0,5	500	126
ELW-HS-0,7	700	180
ELW-HS-1	1000	250
ELW-HS-1,5	1500	375
ELW-HS-2	2000	490
ELW-HS-2,5	2500	622
ELW-HS-3,25	3250	768
ELW-HS-4	4000	987
ELW-HS-5	5000	1260
ELW-HS-6,3	6300	1555
ELW-HS-8	8000	1945

Models ELW-Q

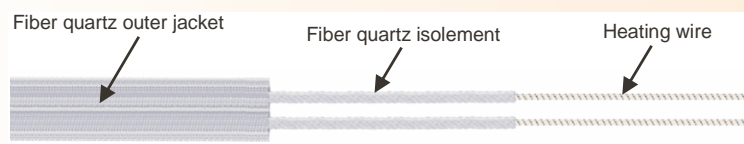

Características técnicas

- Quartz fibre insulation
- Quartz fibre outer cover
- Protection: it depends on the installation
- 1200mm long supply lead
- Dimensions: 25x6mm
- Minimum curvature radius: 10mm
- Maximum working temperature (for ± 350 W/m): +900 °C
- Maximum temperature of the element: +1000°C
- Nominal voltage: ~230 V



Code	Heating length in mm	Total Watts
ELW-Q-0,5	500	138
ELW-Q-0,7	700	270
ELW-Q-1	1000	319
ELW-Q-1,5	1550	533
ELW-Q-2	2000	696
ELW-Q-2,5	2500	882
ELW-Q-3	3000	1062
ELW-Q-4	4000	1438
ELW-Q-5	5000	1653

MINERAL INSULATION HEATING LEAD, MODELS ELK-MI

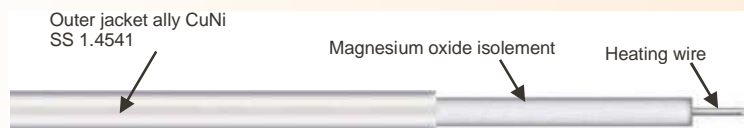

Mineral insulation leads are normally used in bitumen production plants, gas plants, petrol refineries, reactors and in general whenever high temperature maintenance needs to be carried out.

They can be installed in all those applications requiring high power density combined with high temperature.

ELK-MI mineral lead is supplied finished and ready for installing, with 700mm inactive zones at both ends and M20x1.5 connectors.

In your order, the following parameters should be stated:

- Heating length (in mm)
- Nominal supply voltage
- Maximum working temperature

Technical characteristics

- Magnesium oxide insulation
- CuNi stainless steel 1.4541(AISI 321) alloy outer cover
- Cold ends on both sides 700 mm long.
- Dimensions according to ohmic value: Min $\varnothing 3.2$ mm Max $\varnothing 6.5$ mm
- Minimum curvature radius: 5 times the diameter
- Maximum working temperature: see Graph 1
- Maximum temperature of the element:
 - Range ELK-MI/F: +400 °C
 - Range ELK-MI/VA: +600 °C
- Maximum power: Up to 150 W/m depending on the temperature. See Graph 1
- Nominal voltage: Up to 500 V

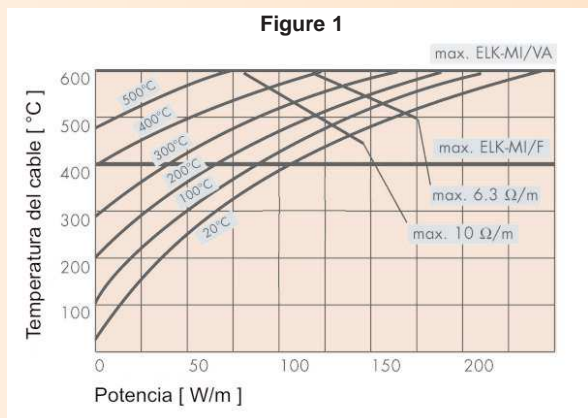

Generally, maximum working temperature is known (in the piping or superficial temperature). The intersection with the working temperature curves shows us the relationship between the maximum temperature of the lead (vertical) and its maximum lineal power (horizontal).

GROUP 4 - Flexible heating elements

4.21 - Accessories and complements for FOR-FLEX and self regulating cable

ACCESSORIES FOR FLEXIBLE HEATING ELEMENTS FOR-FLEX and SELF REGULATING CABLE

	Temperature range	Code
Polyester. Width 12 mm. Yellow. In 30 m rolls	-5 ... 180 °C	128115000
Fiber glass. Width 12 mm. White. In 33 m rolls.	-20 ... 250 °C	128009000
Polyamide-Kapton. Width 13 mm. Orange translucent. In 33 m rolls.	310 °C	128114000

Adhesive tape characteristics

- Polyester. Excellent electric and mechanical resistance, it offers good resistance to abrasion and deterioration by chemicals and heat. (temperature range: -5 °C to 180 °C).
- Fiber glass. Good mechanical resistance, resistant to chemical atmospheres and high temperatures inherent to the material (temperature range: -20 °C to 250 °C).
- Polyimide - Kapton TM. Designed for extreme environments (up to 310 °C continuous). Excellent resistance to chemical attacks.

COMPLEMENTS FOR FLEXIBLE HEATING ELEMENTS FOR-FLEX and SELF REGULATING CABLE

Description	Code
Protective silicone tube for FOR-FLEX and FORMEC-FLEX	109006000
Copper plate connector for FOR-FLEX and FORMEC-FLEX	103083006
Protective silicone tube for FOR-FLEX SUPER	109014000
Copper plate connector for FOR-FLEX SUPER	103079006
Thermostat with clamp for piping. Adjustable 0-90 °C	3503440520

LEGIONELUS

GROUP 11 - Control and regulation

11.7 - Anti-Legionella electronic thermostat

LEGIONELUS 70 acts automatically by means of time cycles selected by the user. This carries out a periodic cleaning of the system by increasing the temperature of the installation over the determined time, guaranteeing a good sterilization of the conduits through which the water circulates and the ACS is accumulated.

Example: Every 7 days the installation maintains a temperature of 60 °C to 70 °C during two hours.

Usual applications

- House buildings.
- Laundries.
- Public centers of great concurrence: gymnasiums, schools, offices, hospitals, hotels, etc.

General characteristics

- Set point temperature indicator
- Adjustment set point temperature installation (T1)
- Regulation of the differential.
- Limitation interval temperature installation (T1) by minimum and maximum.
- Minimum time of disconnection between two connections of the charge of the installation (T1).
- Readjustment calibrated sensor.
- Selection temperature of Legionella elimination (T2), from 40 °C to 80 °C, factory 70 °C.
- Timer during cycle elimination, from 1 minute to 120 minutes. Factory 5 minutes.
- Repetition of the cycle every 1 to 168 hours (7 days), factory 24 hours.
- PIN, protection and blockage of the keyboard.

Technical data

- Range temperature 10 to 95 °C
- Power supply ~230 V (50 / 60 Hz)
- Type of sensor temperature PTC2000
- Dimensions of the sensor Ø6 x 30 mm
- Relay T1 10 (4) A ~250 V NC +NO
- Relay T2 10 (4) A ~250 V NO
- Regulation type ON / OFF
- Colour visualization Red
- Number of buttons 3



Code	Reference	Range
517340000	LEGIONELUS 70. Wall version	10 - 95 °C
517343000	LEGIONELUS 70 RAIL. Rail DIN version	10 - 95 °C

CTX

GROUP 11 - Control and regulation

11.8 - Electronic thermostat. CTX Range

DIGITAL ELECTRONIC THERMOREGULATOR, CTX RANGE

Electronic thermostats with digital visualisation, for controlling temperatures in heating, refrigeration and industry. A microprocessor, with adjustable parameters and the possibility of connecting a temperature alarm.

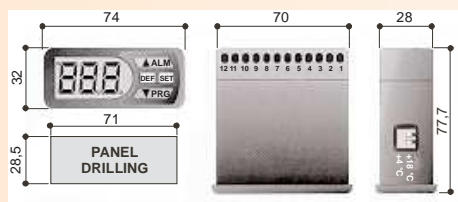

Code	Reference	Range	Sensor type
3501020449	CTX031N00	-45 ... 50 °C	NTC

NOTA: The model CTX031N00 is supplied with incorporated NTC sound. The model CTX031Y00 is supplied **WITHOUT** the PTC sensor, its code being 3501020442

Technical data, CTX031N range

- ON / OFF regulation
- Relay output 8(2)A ~250 V
- Accuracy ± 1 digit
- Sensor accuracy ± 2%
- Front dimensions 32x74 mm
- Working temp. 0 - 50 °C
- Protection: IP52 for the front panel, IP20 for terminals
- Power supply ~230 V



PTC Heaters

Positive temperature co-efficient - PTC heating elements are small ceramic stones with self temperature limiting characteristics. PTC stones have fast heating response times and plateau once the pre-defined reference temperature is reached. The shape of these stones can be designed to be square, rectangular, round, ring or doughnut style. Above the reference temperature, the semiconducting and ferro-electrical properties of the ceramic are utilized to produce a rise in resistance of several orders of magnitude, and hence produce its self limiting properties.

This resistance rise can be experienced over a temperature range of a few degrees Celsius. This PTC attribute results in a heating element that self-regulates at a pre-set temperature and automatically varies its wattage in order to maintain that pre-set temperature. Hence, a greater degree of thermal dissipation (cooling) will result in higher power.

The materials used are doped polycrystalline ceramics based on barium titanate. Once the ceramic body has been formed through processes including blending, milling, drying and sintering, metallized contacts are applied to the surface to facilitate electrical connection.

PTC Design Guidelines/Considerations

Listed below are some items that should be taken into consideration when a PTC heater is specified:

- Specify target temperature to be maintained
- Specify maximum allowable temperature
- Specify the time required to heat the media to target temperature
- Identify the type of medium to be heated
- Identify any potential thermal barriers between heater and media
- Specify maximum allowable inrush current at startup of element
- Voltage
- Inlet air temperature/CFM rating
- Space/size constraints for heater

PTC Features & Benefits

- Safe through temperature limiting characteristics
- Dynamic, self regulating, and therefore energy efficient
- All voltages from 12 V to 240 V; special voltage applications up to 800 V
- Dual voltages 12-24 V, 100-240 V
- PTC surface temperatures can be set from 40° C to 280° C
- Temperature tolerances ± 5° C
- Compact design
- High power density
- Long lifetime
- Reliable
- UL, CSA and VDE recognised
- Custom configurations available in regards to size, inrush current, temperature, voltage, and power output

BUILT-IN PTC HEATERS, EA and EB RANGES

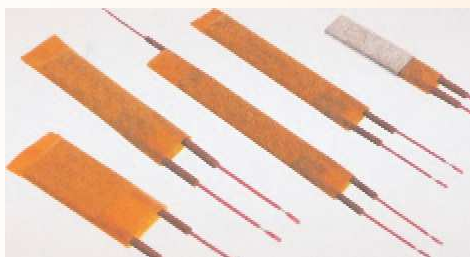

Basic heating element for installation in sites where sufficient clamping contact must be guaranteed. This is necessary in order to continuously maintain optimum heat transfer.

General characteristics

- Combination of heating and control in one element.
- Automatic control function.
- Protection: Class II (3750 V - 1 min)
- Virtually constant power input within a wide range of voltage: 100 - 240 V.
- Safety and longterm stability by self-regulating effect.

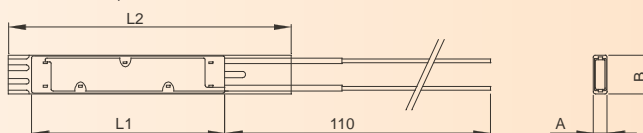

Code	Max. power	Reference temperature PTC	Nº PTC	Dimensions in mm			
				L1	L2	A	B
EA01-4/06	110 W	60 °C	4	73	120 ± 2	3,5 ± 0,1	18,5 ± 0,2
EA01-4/12	210 W	120 °C	4	73	120 ± 2	3,5 ± 0,1	18,5 ± 0,2
EA01-4/18	150 W	180 °C	4	73	120 ± 2	3,5 ± 0,1	18,5 ± 0,2
EA01-4/23	180 W	230 °C	4	73	120 ± 2	3,5 ± 0,1	18,5 ± 0,2
EB04-1/07	15 W	70 °C	1	32	55 ± 2	3,5 ± 0,1	9,5 ± 0,2
EB04-1/09	17 W	90 °C	1	32	55 ± 2	3,5 ± 0,1	9,5 ± 0,2
EB04-1/13	23 W	130 °C	1	32	55 ± 2	3,5 ± 0,1	9,5 ± 0,2
EB05-1/09	45 W	90 °C	1	40	62 ± 2	2,7 ± 0,15	14,2 ± 0,2
EB05-1/13	50 W	130 °C	1	40	62 ± 2	2,7 ± 0,15	14,2 ± 0,2
EB05-1/18	90 W	180 °C	1	40	62 ± 2	2,7 ± 0,15	14,2 ± 0,2
EB06-2/18	160 W	180 °C	2	75	97 ± 2	2,7 ± 0,15	14,2 ± 0,2
EB06-2/24	200 W	240 °C	2	75	97 ± 2	2,7 ± 0,15	14,2 ± 0,2

PTC HEATERS WITH ALUMINIUM PROFILE, HP02 RANGE

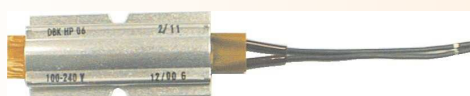

The HP series features a compact design and high power density. The flat aluminium housing can be easily installed and ensures optimum heat transfer. The ready-to-use heating element can be fixed using fixing holes on the profiles (e.g. drilled or punched mounting holes).

General characteristics

- Combination of heating and control in one element.
- Automatic control function.
- Protection: Class II (3750 V - 1 min)
- Virtually constant power input within a wide range of voltage: 100 - 240 V.
- Safety and longterm stability by self-regulating effect.

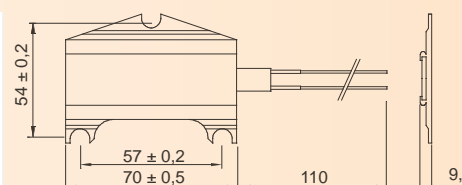

Code	Max. power	Reference temperature PTC	Nº PTC
HP02-4/06	110 W	60 °C	4
HP02-4/12	210 W	120 °C	4
HP02-4/18	150 W	180 °C	4
HP02-4/23	180 W	230 °C	4
HP02-4/27	275 W	270 °C	4



PTC HEATERS WITH ALUMINIUM PROFILE, HP RANGE

The HP series features a compact design and high power density. The flat aluminium housing can be easily installed and ensures optimum heat transfer. The ready-to-use heating element can be fixed using fixing holes on the profiles (e.g. drilled or punched mounting holes).

General characteristics

- Combination of heating and control in one element.
- Automatic control function.
- Protection: Class II (3750 V - 1 min)
- Virtually constant power input within a wide range of voltage: 100 - 240 V.
- Safety and longterm stability by self-regulating effect.



Code	Max. power	Reference temperature PTC	Nº PTC	Dimensions in mm		
				L1	A	B
HP01-4/18	200 W	180 °C	4	250	9,5	70
HP01-4/22	250 W	220 °C	4	250	9,5	70
HP04-1/07	15 W	70 °C	1	40	8,5 ± 0,3	35
HP04-1/09	17 W	90 °C	1	40	8,5 ± 0,3	35
HP04-1/13	23 W	130 °C	1	40	8,5 ± 0,3	35
HP05-1/09	40 W	90 °C	1	40	7 ± 0,3	35
HP05-1/13	50 W	130 °C	1	40	7 ± 0,3	35
HP05-1/18	90 W	180 °C	1	40	7 ± 0,3	35
HP06-2/18	160 W	180 °C	2	75	7 ± 0,3	35
HP06-2/24	200 W	240 °C	2	75	7 ± 0,3	35

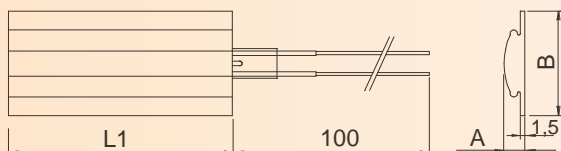

PTC HEATERS WITH ALUMINIUM PROFILE, HT RANGE

High-quality compact disc heating element with central mounting hole. The concave pre-stressed contact surface ensures form-fit contact and thus an optimum heat transfer. Equipped with spade terminals for electrical connection.

Models HT01

Code	Max. power	Reference temperature PTC	Nº PTC
HT01-3/23	90 W	230 °C	3
HT01-3/27	120 W	270 °C	3

Models HT02

Code	Max. power	Reference temperature PTC	Nº PTC
HT02-4/18	170 W	180 °C	4
HT02-4/23	200 W	230 °C	4
HT02-4/27	375 W	270 °C	4

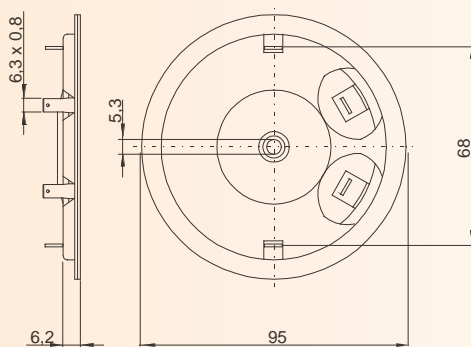
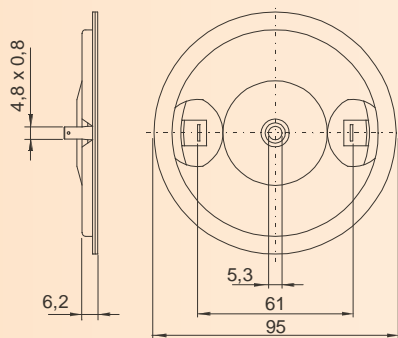

General characteristics

- Combination of heating and control in one element.
- Automatic control function.
- Protection: Class I (1250 V - 1 min)
- Virtually constant power input within a wide range of voltage: 100 - 240 V.
- Safety and longterm stability by self-regulating effect.
- With M5 central hole for fastening to flat surfaces



PTC HEATING ELEMENT FOR PIPE DEFROSTING APPLICATIONS. FE RANGE

Due to a prismatic contact area this element is eminently suitable for attachment to tubes with a diameter of approx. 6 - 14 mm. Fixing clips for attachment to the tube can be supplied separately.

General characteristics

- Stable power approx. 10 W
- Virtually constant power input within a wide range of voltages: 100 - 240 V.
- Max surface temperature approx. 140 °C.
- Protection: Class I (1250 V - 1 min).
- Heating element can be supplied with or without thermostat, normally closed, of 17 °C with differential of 9 °C.
- Ceramic casing with degree protection against moisture IP-54.

Code	Description	Max. power
FE10	PTC heating element to join to pipes Ø6 mm to Ø14 mm. Protection IP54	10 W
FE10-C	PTC chain of 5 elements FE10 to join to Ø6 mm to Ø14 mm. Protection IP54. With bimetallic thermostat of 17 °C.	53 W

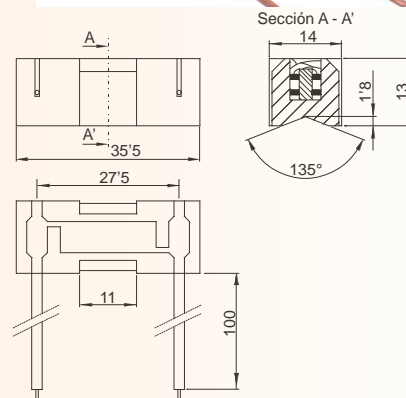
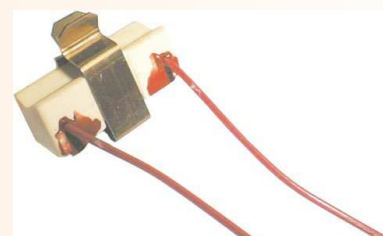

PTC HEATING ELEMENTS TO HEAT MOVING AIR, MODELS HR

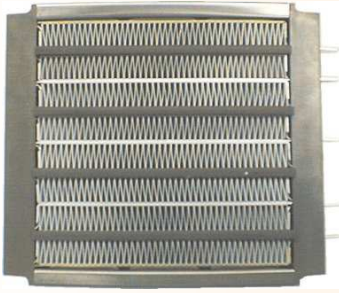

PTC finned resistor heaters are dynamic heating elements designed to heat up moving air. The large surface area of the aluminum fins ensures a homogeneous heat transfer adjusting the air volume flow. This system allows an automatic regulation of the heating power within certain ranges. Due to the features, there are many application possibilities. In addition to the standard types, special versions for specific applications are available.

General characteristics

- Combination of heating and control in one element.
- Automatic control function.
- Virtually constant power input within a wide range of voltages: 220 - 240 V.
- Long life-time if properly used.
- Safety and longterm stability by self-regulating effect.
- Protection: Class I (1250 V - 1 min)

Usual applications

- Fan heating appliances (domestic use).
- Car heaters
- Tumble dryers.
- Industrial air heaters.
- Exchange heaters
- De-frost heaters.

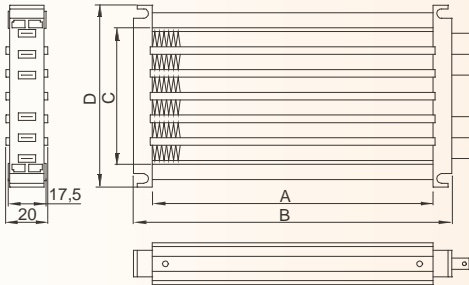

Code	Max. power	Reference temperature PTC	N° PTC	Dimensions in mm			
				A	B	C	D
HR04-25/18-IS	2000 W	180 °C	25	150	174	72,5	100,5
HR06-10/18-IS	950 W	180 °C	10	150	174	45	70,5
HR20-12/22-IS	1500 W	220 °C	12	96	120,5	93	107,5
HRKK-3000	3000 W	260 °C	36	288	314	81,6	92,2

GROUP 5 - Self regulating heating elements

Many products working in changeable temperature atmospheres need to maintain a constant operating climate and the HKL helps provide the perfect environment, allowing for optimum efficiency.

The flexibility of the range ensures that all applications are covered and innovations such as Smartcon® cabling and flexible mounting systems mean that HKL heaters can be tailored to individual needs

General characteristics

- Compact
- Ready for fitting, fitting options
- High quality design and manufacture
- Smartcon® cable for flexible power inputs
- Fan can be used in isolation for air circulation
- One piece fan/heater/cable assembly - reduced parts count, supplier base and assembly time
- Excellent size to power ratio
- Finger guards can be factory fitted
- 600 mm cable set included

MODELS HKL 25 (*)

Technical data

- **Power supply** according to table
- **Heating power** according to table
- **Heating element** PTC. Self regulating element
- **Radiator** Anonized aluminium
- **Axial fan** 2,7 m³/h free output
82.000 h gan lifetime at 50 °C
- **Electrical class** I (for heaters with 100 - 240 Vca power supply)
III (for heaters with 12 / 24 Vcc power supply)
- **Degree protection against moisture** IP20
- **Fixation** fixing clip for 35 mm DIN rail
- **Homologation** VDE, CSA, UL

Code	Volts		Heating power (T _{amb} = 10 °C)	Typical max. inrush current			Dimensions in mm	
	Heater	Fan		at 12 V	at 24 V	at 230 V	A x B	L
HKL 25/1-10L	12 Vcc	12 Vcc	10 W	2 A	-	-	27 x 27	50
HKL 25/1-10	24 Vcc	24 Vcc / Vca	10 W	-	2 A	-	27 x 27	50
HKL 25/2-20L	12 Vcc	12 Vcc	20 W	2 A	-	-	27 x 27	72
HKL 25/2-20	24 Vcc	24 Vcc / Vca	20 W	-	4 A	-	27 x 27	72
HKL 25/2-20H	100 - 240 Vca	24 Vcc / Vca	20 W	-	-	3 A	27 x 27	72



MODELS HKL 40 (*)

Technical data

- **Power supply** according to table
- **Heating power** according to table
- **Heating element** PTC. Self regulating element
- **Radiator** Anonized aluminium
- **Axial fan** 9,3 m³/h free output
82.000 h gan lifetime at 50 °C
- **Electrical class** I
- **Degree protection against moisture** IP20
- **Fixation** fixing clip for 35 mm DIN rail
- **Homologation** VDE, CSA, UL

Code	Volts		Heating power (T _{amb} = 10 °C)	Typical max. inrush current at ~230 V	Dimensions in mm	
	Heater	Fan			A x B	L
HKL 40/1-45L	100 - 240 Vca	12 Vcc	45 W	9 A	42 x 42	72
HKL 40/1-45H	100 - 240 Vca	24 Vcc / Vca	45 W	9 A	42 x 42	72
HKL 40/1-100L	100 - 240 Vca	12 Vcc	100 W	13 A	42 x 42	72
HKL 40/1-100H	100 - 240 Vca	24 Vcc / Vca	100 W	13 A	42 x 42	72



Common dimensions models HKL

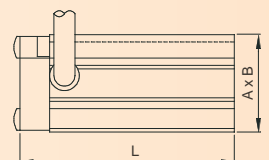

General characteristics

The infrared emitters, in single tube or twin tube version, can be made with different wavelengths:

- **Medium wave** → Minimum thermal inertia
- **Fast medium wave** → Absence of thermal inertia
- **Long medium wave** → Minimum thermal inertia
- **Short wave** → Absence of thermal inertia
- **Halogen** → Absence of thermal inertia

The different frequency choice depends on material absorbency, heating necessities, speed and type of application.

The gold reflector on the back of the twin-tube emitter increases radiation yield and enhances directionality.

Use of twin tube of quartz crystal turns it into a much more stable element than the normal single tube. Loss of radiation through the ends is minimal.

Infrared in twin tube version can be manufactured with one single connection end, simplifying installation.

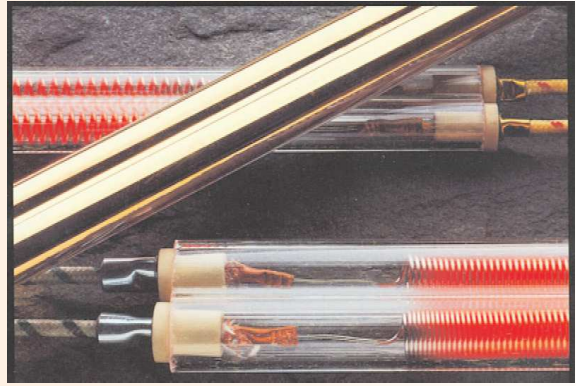

Advantages

- Heating energy is transferred so quickly to the object that its surface reaches curing temperature with a minimum heating of the support.
- Minimum thermic inertia.
- Accurate adjustment and energy saving.
- Localised in-depth surface heating.
- High quality in finish of treated product.
- Reduced size of installations.
- No atmospheric pollution nor harmful action on foods.

Usual applications

- Pre-heating and heating.
- Drying
- Polymerization.
- Thermo-fixing.
- Cooking.
- Defrosting.
- Toasting.
- Sterilisation.
- Dehydration.
- Fusing.
- Sealing

Applications in industry are::

- Glass.
- Paper.
- Plastic.
- Food.
- Paint.
- Graphic arts.
- Textile.
- Rubber.
- Metal.
- Ceramics.
- Wood, etc...

LONG WAVE INFRARED EMITTERS, MODELS 77F

General characteristics

Minimal thermic inertia.

The cheapest and most reliable solution. Efficient drying in the shortest time

- Manufactured in transparent or translucent quartz crystal.
- With or without built-in gold reflector.
- Connection by leads or screw.
- Steatite insulators.
- To order, tubes are made to the client's requirement, their power, voltage and length etc being able to be varied. The support system will be by clips manufactured in stainless steel

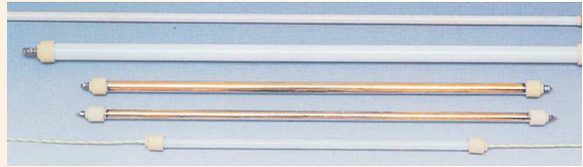

Code	Dimensions in mm			Material tube	Volts	Watts
	Section tube	A	B			
77F00315	Ø8 x Ø10	830	785	Translucent quartz	~ 220 V	1200
77F09315	Ø10 x Ø12	930	850	Translucent quartz	~ 220 V	1500
77F09615	Ø10 x Ø12	1415	1355	Translucent quartz	~ 220 V	2500
77F08315	Ø14 x Ø18	1525	1440	Translucent quartz	~ 380 V	2200
77F13015	Ø14 x Ø18	2225	2150	Translucent quartz	~ 220 V	4500

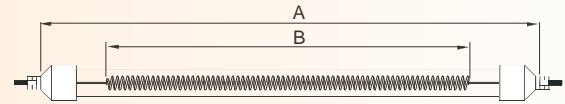

Specific characteristics models 77F

All standard models of the range 77F are supplied by AISI316 stainless steel screw connection.

LONG WAVE INFRARED EMITTERS IN SILICA TRANSLUCENT QUARTZ GLASS, SPECIAL MANUFACTURES

To correctly facilitate and identify the infrared emitter, complete the attached table bearing in mind the corresponding diagrammes:

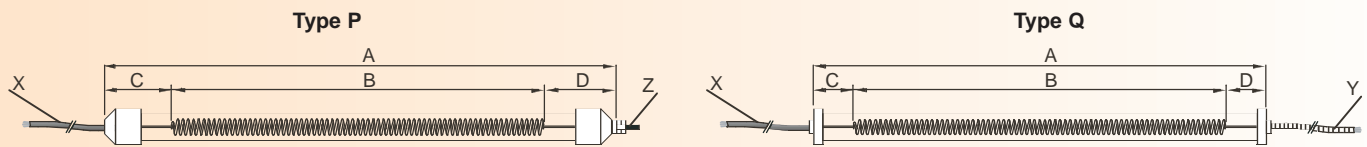

Type P <input type="checkbox"/>	Type Q <input type="checkbox"/>	Dimensions in mm		Volts	Watts	
Tube section		A	Connections			
Ø8 x Ø10 <input type="checkbox"/>	<input type="checkbox"/>	B	Z (screw)	<input type="checkbox"/>	Length	
Ø10 x Ø12 <input type="checkbox"/>	<input type="checkbox"/>	C	X (cable)	<input type="checkbox"/>		
Ø14 x Ø18 <input type="checkbox"/>	<input type="checkbox"/>	D	Y (The cable is covered with steatite material)	<input type="checkbox"/>	Length	
Ø19 x Ø26 <input type="checkbox"/>	<input type="checkbox"/>					
WITH gold reflector <input type="checkbox"/>	<input type="checkbox"/>					
WITHOUT gold reflector <input type="checkbox"/>	<input type="checkbox"/>					



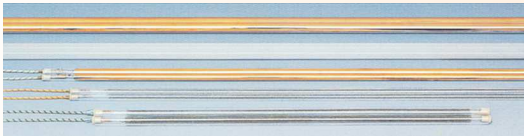

MEDIUM WAVE INFRARED EMITTERS, MODELS 77P

General characteristics

Minimum thermic inertia.

Suitable for a wide variety of industrial applications. With high penetration power in almost all materials. For processes in which fast, powerful drying is required.

- Manufactured in transparent quartz crystal.
- With or without built-in gold reflector
- One or two connection ends.
- To order, tubes are made to the client's requirement, their power, voltage and length etc. being able to be varied. The support system will be by clips manufactured in stainless steel.

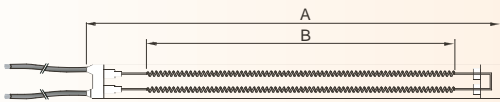

Code	Dimensions in mm			Tube material	Volts	Watts
	Tube section	A	B			
77P001I5	18 x 9	400	300	Transparent quartz	~ 220 V	500
77P127I5	22 x 10	900	800	Transparent quartz	~ 220 V	1000
77P057I5	22 x 10	1300	1200	Transparent quartz	~ 220 V	2500
77P191I5	33 x 16	1600	1500	Transparent quartz	~ 230 V	3750
77P110I5	33 x 16	2410	2300	Transparent quartz	~ 380 V	5750
77P308I5	33 x 16	2100	2000	Translucent quartz	~ 380 V	5000

Specific characteristics models 77P

All standard models of the range 77P are supplied with gold reflector and supply connection by 500m long leads

MEDIUM WAVE INFRARED EMITTERS IN TRANSPARENT QUARTZ GLASS TWIN TUBE, SPECIAL MANUFACTURES

To correctly facilitate and identify the infrared emitter, complete the attached table bearing in mind the corresponding diagrammes:

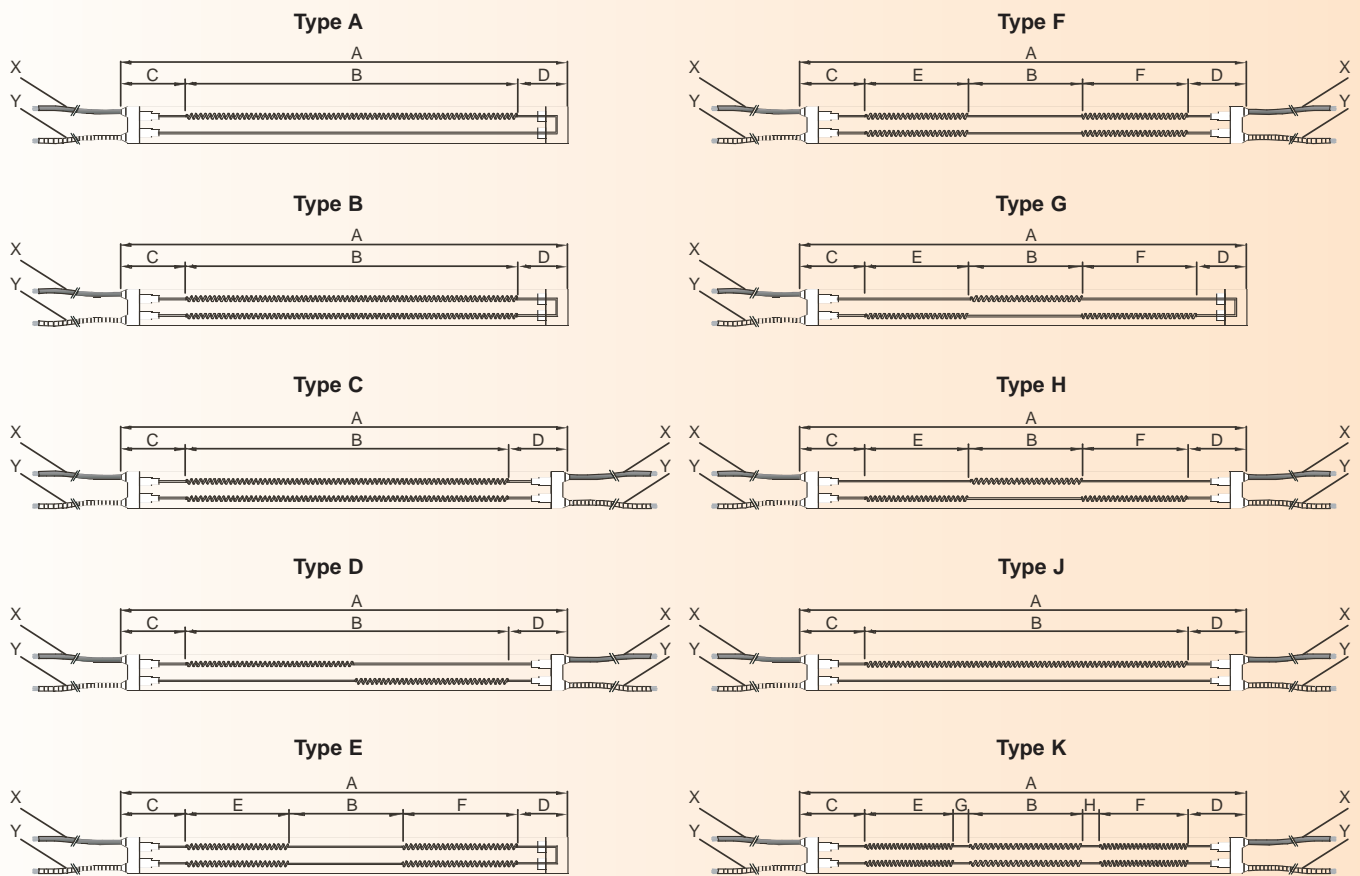

Type	Dimensions in mm		Volts	Watts
	Tube section	A	B	Connections
33 x 16 <input type="checkbox"/>	C	D	X (cable) <input type="checkbox"/>	Length
22 x 11 <input type="checkbox"/>	E	F	Y (The cable is covered with steatite material) <input type="checkbox"/>	Length
18 x 9 <input type="checkbox"/>	G	H		
WITH gold reflector <input type="checkbox"/>				
WITHOUT gold reflector <input type="checkbox"/>				



SHORT WAVE INFRARED EMITTERS, MODELS 81P

General characteristics

Absence of thermic inertia.

Suitable for a wide variety of industrial applications. With high penetration power in almost all materials. For processes in which fast, powerful drying is required.

- Manufactured in transparent quartz crystal.
- With or without built-in gold reflector
- One or two connection ends.
- To order, tubes are made to the client's requirement, their power, voltage and length etc. being able to be varied. The support system will be by clips manufactured in stainless steel.



Specific characteristics models 81P

All standard models of the range 81P are supplied with gold reflector and supply connection by 500m long leads

Code	Dimensions in mm			Volts	Watts
	Tube section	A	B		
81P024B5	22 x 11	405	340	~ 230 V	1200
81P078C5	22 x 11	850	700	~ 230 V	4200
81P069C5	22 x 11	1150	1000	~ 400 V	6000

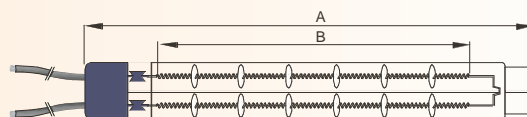

SHORT WAVE INFRARED EMITTERS IN TRANSPARENT QUARTZ GLASS SINGLE TUBE, SPECIAL MANUFACTURES

To correctly facilitate and identify the infrared emitter, complete the attached table bearing in mind the corresponding diagrams:

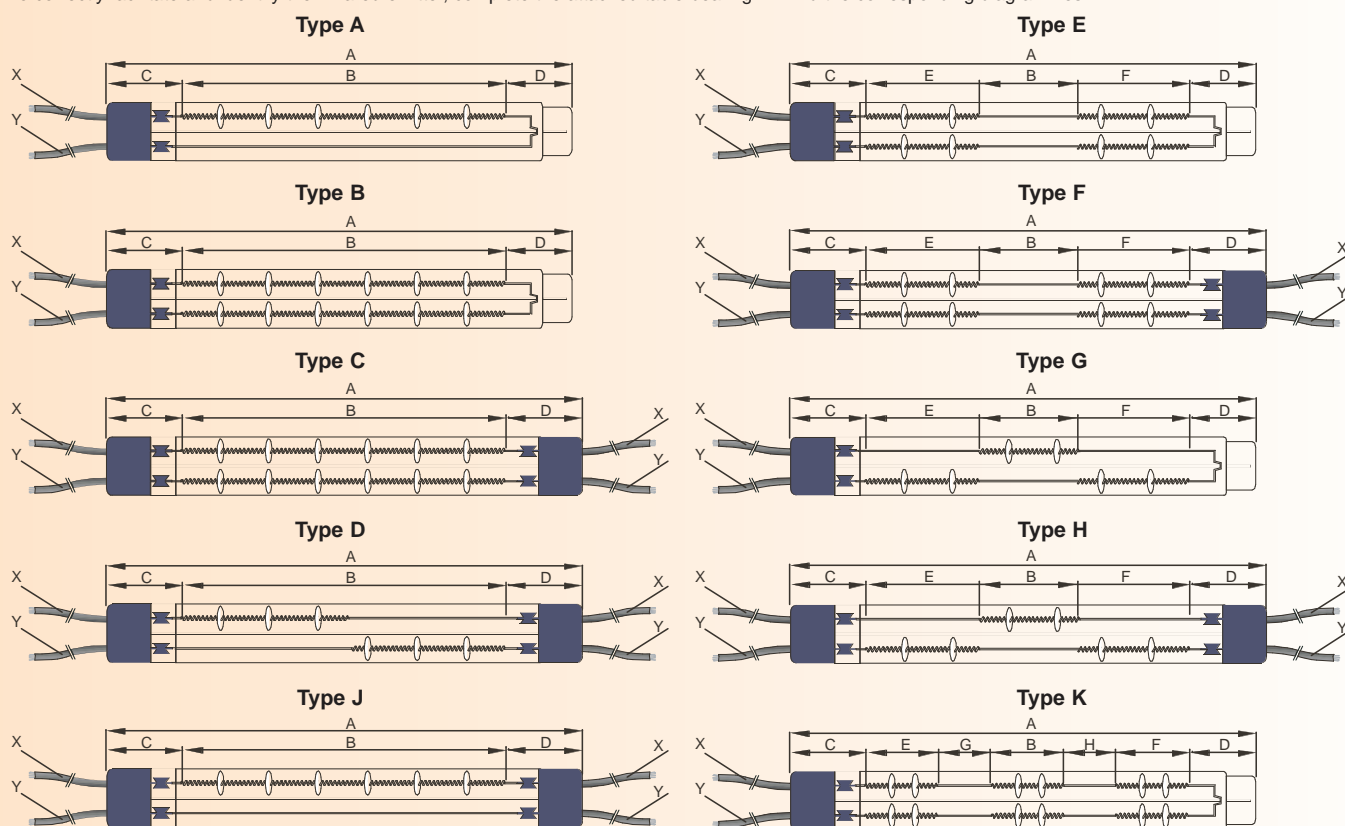

Type	Dimensions in mm		Volts		Watts	
	Section tube	A	B	Connections		
33 x 16 <input type="checkbox"/>	C	D	X (cable)	<input type="checkbox"/>	Length	
22 x 11 <input type="checkbox"/>	E	F		Y (The cable is covered with steatite material)	<input type="checkbox"/>	Length
WITH gold reflector <input type="checkbox"/>	G	H				
WITHOUT gold reflector <input type="checkbox"/>						



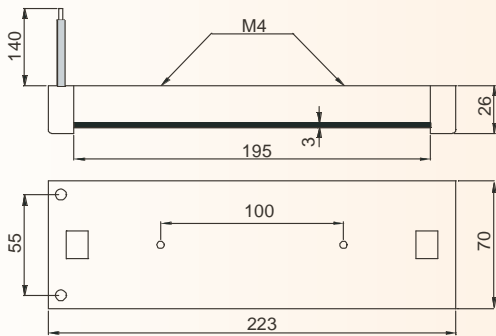

Code	Volts	Watts
IRU 1	~230 V	1050

UNIVERSAL CERAMIC INFRARED EMITTERS. SHORT - MEDIUM - LONG WAVE.

MODEL IRU

General characteristics

The IRU range of ceramic infrared emitters combines numerous innovations that allow responding to the difficulties of the most demanding industrial process: saving energy, faster productive process, quality control...

The main advantages of infrared radiation with respect to the classic techniques of heating based on convection or conduction are the rapidity and flexibility of use, absence of contact with the products that must be treated and the high density load that can be reached.

IRU emitter is manufactured with a ceramic plate of 3 mm thickness resistant to thermal shocks and low inertia due to its small mass. The addition of a special covering with high emissivity allows an optimal conversion of electrical energy in infrared radiation.

The total emissivity of the IRU emitter, calculated at 800 °C, on the spectral field located from 10 to 7000 cm-1 is 0'98 (in comparison with a black body e = 1). The effectiveness of the IRU emitter in relation to an idela radiation is 98% over the entire infrared spectre. In comparison, the emission factor in a metallic body is 50%, in a quartz tube it is 70%.

In the attached table, one can observe the behaviour of IRU emitter relating power to superficial temperature. By means of a energy regulator MR1 (Code 517193000 page nº 109) we can vary the power/superficial temperature of the emitter in such a way that the emitter will work along the indicated wavelength.

Technical data

Electrical power	300 W	500 W	700 W	900 W	1050 W
Superficial temperature	300 °C	462 °C	584 °C	697 °C	780 °C
Wavelength for maximum emissivity (λ)	5,1 μm	3,9 μm	3,4 μm	3 μm	2,8 μm
Transmitted power (KW/m²)	23 KW/m²	39 KW/m²	55 KW/m²	70 KW/m²	82 KW/m²

GROUP 6 - Infrared radiation equipment

6.3 - Quartz industrial halogen-infrared emitters

LCP / LCU

QUARTZ INDUSTRIAL HALOGEN-INFRARED EMITTERS. SHORT WAVE. MODELS LCP and LCU

General characteristics

The industrial quartz halogen infrared emitters are short wave high power heat emitters, with two contacts and tungsten filament. The spectral range of infrared is specified from 700 to 1800 nm with a maximum radiation of 1200 nm.

They benefit from the same technology used by halogen lighting lamps, sharing their same advantages: they hardly darken and they have a very long operating life (5000 h average life).

Advantages

- High velocity.
- Safety, cleaning and easy installation.
- Thermal stability.
- Easy to use.

Working temperature range

In emitter: 900 °C maximum.
250 °C minimum.
In connector: 350 °C maximum.

Usual applications

- Industrial and chemical processes.
- Thermal process: sterilizing, fusion, carbonizing.
- Thermoplastics.
- Control of humidity in paper industry.
- Printers.
- Food industries.
- Drying of adhesives by flash.
- Keeping food warm (in restaurants)

WITH R7s TYPE CONTACT

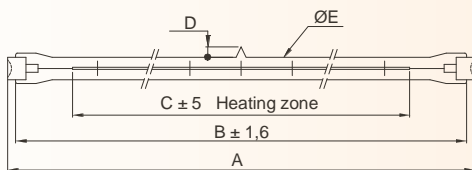

Code	Volts	Watts	W/cm²	Dimensions in mm					Position
				A	B	C	Dmáx	ØEmáx	
LCP030R	~230	300	50	118	114,6	60	5	11	P15
LCP050R	~230 - 250	500	30,3	221	217,2	165	5	11	P15
LCP150R	~230	1530	39,7	448	444,5	385	-	9	P15
LCP200R	~230	2000	40	550	547	497	-	11	P15

WITH X TYPE CONTACT

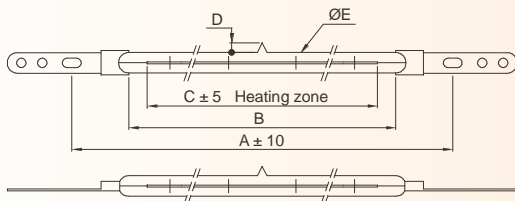

Code	Volts	Watts	W/cm²	Dimensions in mm					Position
				A	B	C	Dmáx	ØEmáx	
LCP050X	~110 - 130	500	30,3	241	165	142	-	11	P15
LCP100X	~220 - 250	1000	36,8	370	295	272	-	11	P15
LCU100X	~220 - 250	1000	36,8	370	295	272	5	11	Universal
LCU200X	~220 - 250	2000	71,4	370	295	282	5	11	Universal
LCU201X	~380 - 420	2000	48,8	508	435	410	5	11	Universal
LCU300X	~380 - 420	3000	42,9	798	725	700	5	11	Universal

1.- Working lamp position.

The emitters with reference position P15 must be operated in horizontal position with a tolerance of ±15°. The emitters with reference position Universal can be operated at any position.

The suitable positions for use are represented inside a white circle, black areas are the wrong positions.

Universal position

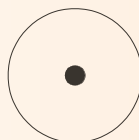

Horizontal position P15

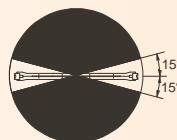

2.- Handling.

Quartz lamps shouldn't be handled with bare hands (use cloth, felt, chamois gloves, etc). Otherwise, bulb stains eventually deteriorate the lamp.

3.- Recommendations:

- Don't touch the emitters without protection (gloves, felt, etc.)
- The stated temperatures must be respected.
- Staring at the lamp while working may cause eye damage



General characteristics

IRCM and IRCC infrared emitters are manufactured with two types of tungsten filaments: porcupine or star type for rapid medium wave emitters and spiral type supported for halogen short wave emitters.

Heating and cooling of the emitters takes a few seconds, making them especially suitable for systems requiring short cycle times

The choice of emitter type (medium or short wave) depends on absorption of material, specific heating needs, process speed and type of application.

Advantages

- Heating energy transfers so rapidly to the object that its surface reaches curing time with a minimal heating of the support.
- Minimum thermal inertia.
- Accurate adjustment and energy saving
- High quality in the finish of the treated product
- Heating localised on surface and in depth
- Reduced size of installations
- No environmental contamination or harmful action on foods

Normal applications

- Preheating and heating.
- Drying
- Polymerisation.
- Heat-fixing.
- Cooking
- Defrosting.
- Toasting
- Sterilising.
- Dehydrating.
- Fusion.
- Sealing

Applications in industry of:

- Glass
- Paper.
- Plastic.
- Food.
- Paint.
- Graphic arts.
- Textile.
- Rubber.
- Metal.
- Ceramics.
- Wood, etc...

MEDIUM WAVE INFRARED EMITTERS, IRCM MODELS

Specific characteristics

The tungsten filament used in these heaters is porcupine or star type. It can work with temperatures up to 1500°C, with a wavelength emission peak of about 1.6 μm.

Response time is a few seconds.

Apart from achieving excellent structural rigidity, the porcupine type spiral is designed to reduce to a minimum light emission and maximise IR emission, thus increasing IR radiant efficacy.

- Minimum thermal inertia.
- Manufactured in transparent quartz crystal
- Connection by R7screw fittings.
- To order, the tubes are manufactured to the client's requirements, with wattage, voltage, length etc able to be varied.

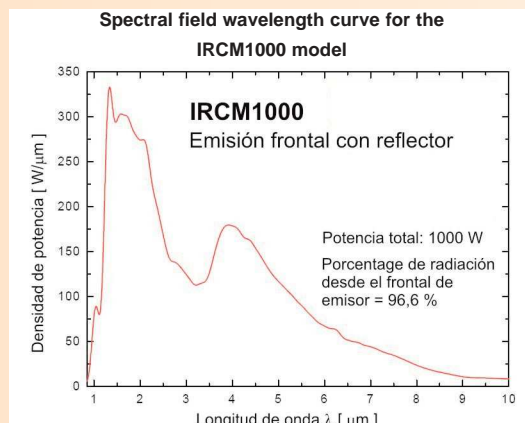
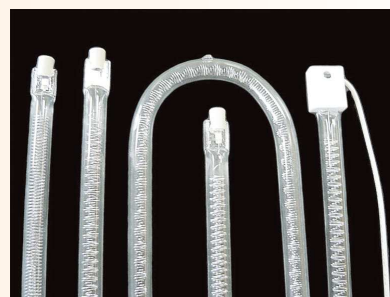

Code	Volts	Watts	Dimensions in mm			Maximum temperature's wire
			Ø tube	Total length	Heating length	
IRCM750	~230 V	750	10	277	225	1210 °C
IRCM1000	~230 V	1000	10	277	225	1450 °C
IRCM1500	~230 V	1500	10	473	415	1270 °C
IRCM1750	~230 V	1750	10	473	415	1470 °C
IRCM2000	~230 V	2000	10	473	415	1500 °C

SHORTWAVE INFRARED EMITTERS, IRCC MODELS

General characteristics

IRCC shortwave infrared halogen emitters allow the tungsten filament to reach temperatures up to 2600°C, with a wave length emission peak approximately 1.0 μm.

With an extraordinarily quick response time, they allow On/off cycles suitable for any application.

- Minimum thermal inertia.
- Manufactured in transparent quartz crystal
- Connection by R7screw fittings.
- To order, the tubes are manufactured to the client's requirements, with wattage, voltage, length etc able to be varied.

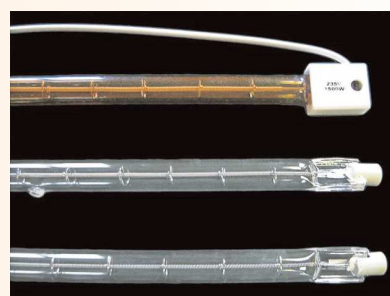

Code	Volts	Watts	Dimensions in mm			Maximum temperature's wire
			Ø tube	Total length	Heating length	
IRCC1000	~240 V	1000	10	277	235	2410 °C
IRCC2000	~240 V	2000	10	473	425	2250 °C

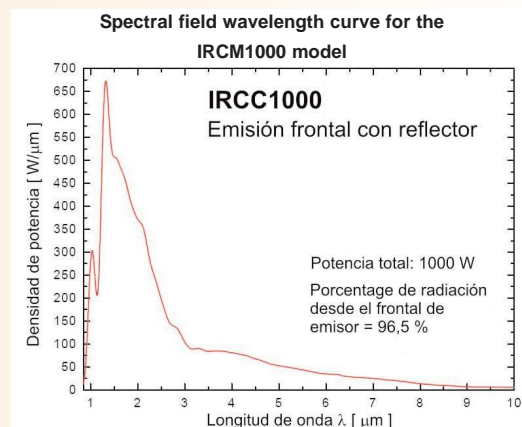

Ceramic R7 supports

General characteristics

Ceramic supports used for assembling infrared emitters with R7 screw fittings

- Voltage: 250 V
- Max intensity: 8A
- Maximum temperature: 350 °C
- Leads: 190 mm long with PTFE insulation (maximum 250 °C)
- Connection with M4 screw

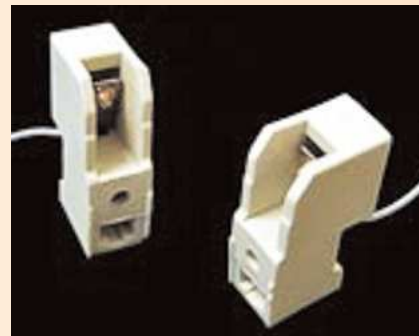

Code	Dimensions in mm (wide x length x height)
HR7S	15 x 44,5 x 25,2

Aluminium reflecting screens for IRCM and IRCC infrared emitters

General characteristics

High reflectivity reflecting screens maximise the performance of infrared emitters.

The screens are supplied with ceramic R7 supports allowing easy, quick and safe installation of IRCM and IRCC emitters.

- Material: polished aluminised steel. To order, they can be supplied with gold coating
- Thickness: 0.75 mm
- Maximum temperature: 500 °C.

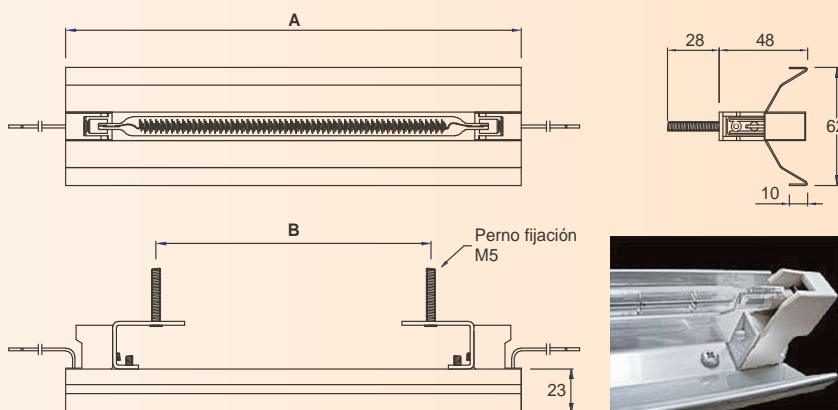

Code	Dimensions in mm	
	A	B
PRA-IRC-277	302	204
PRA-IRC-473	497	399

INFRARED HEATING EQUIPMENT. MODELS FIR

Infrared heating equipment represents a compact and robust heating system. It is the ideal solution for installation of IRCM and IRCC infrared emitters.

With the FIR units, you will be able to achieve high energy performance thanks to the high reflectivity polished aluminised steel reflectors and the axial ventilators fitted at the back of the unit which eliminate heat loss by convection.

The outer shell manufactured in mild steel, oven painted red, remains at a temperature safe to the touch.

Easy and quick to install, they allow working arrangements with other medium and short wave emitters, as well as combinations of both medium and short wave emitters.

Frontal and rear view

FIRM4 - FIRM5 - FIRC4 - FIRC5

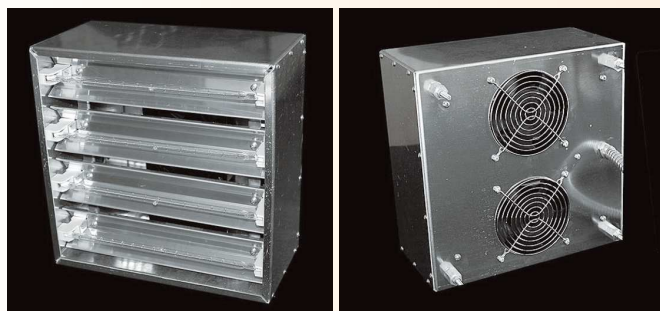

Frontal and rear view

FIRM12 - FIRM14 - FIRC12 - FIRC14



Medium wave heating equipment, models FIRM

Code	Volts	Watts	Dimensions in mm (wide x length x high)	Configuration	Emitters type
FIRM4	~240 V	4000	305 x 305 x 150	4 emitters IRCM	Medium wave. IRCM1000
FIRM5	~240 V	5000	305 x 305 x 150	5 emitters IRCM	Medium wave.. IRCM1000
FIRM12	~240 V	12000	500 x 500 x 150	6 emitters IRCM	Medium wave.. IRCM2000
FIRM14	~240 V	14000	500 x 500 x 150	7 emitters IRCM	Medium wave.. IRCM2000

Short wave heating equipment, models FIRC

Code	Volts	Watts	Dimensions in mm (wide x length x high)	Configuration	Emitters type
FIRC4	~240 V	4000	305 x 305 x 150	4 emitters IRCC	Short wave. IRCC1000
FIRC5	~240 V	5000	305 x 305 x 150	5 emitters IRCC	Short wave IRCC1000
FIRC12	~240 V	12000	500 x 500 x 150	6 emitters IRCC	Short wave IRCC2000
FIRC14	~240 V	14000	500 x 500 x 150	7 emitters IRCC	Short wave IRCC2000



The ceramic heater is an efficient and robust heater that provides long and medium wavelength infrared radiation. It is used in applications that range from thermoforming or preheating, to the processing of foundry blacking. Almost all materials needing drying or heating have a maximum absorption of between 3 and 7 microns. The ceramic heater was developed with this idea in mind and it is the reason why it can be applied to so many different examples of industrial processes.

The ceramic heater is manufactured using a specialised process that requires the alloying of an electrically resistive wire, which is fused to the ceramic body. Subsequently, the ceramic body is given a layer of enamel to protect it from humidity. Moreover, it protects the heater from corrosive and atmospheric attack. In this way, ceramic heating elements optimise the characteristics of maximum absorption, operating at temperatures which range from 300°C to 750°C, with the emission of wavelengths ranging from 3 to 7 microns.

The ceramic heater has been designed so as to offer a very high efficiency (more than 85% in appropriately designed systems), flexibility of arrangement, interchangeability for maintenance, long life, and uniformity from heating element to heating element. The ceramic heating elements are the chosen heaters in the majority of applications that require efficiency of radiation at a competitive price.

In addition to the OSCxxK models, on order its possible provide the models OSCP, OSPG and OSPP with built-in K type thermocouple

Usual applications

Mass heating

- Softening of plastic for thermoforming machines.
- Preheating of vacuum formed sheets.
- Heat adjustment of asbestos cloth after weaving.
- Retraction of plastics.
- Soldered recirculation/ Wave ovens.
- Closing of glass joints on metal and bending of the glass

Drying applications

- Continuous paper tape and impregnated protective layers.
- Water based dyes, protective layers, and adhesives.
- Drying of paint.
- Memory panels and woods.
- Enamelling on ceramic.

Heating and treatment applications

- Vaporisation and oxidising powder treatments.
- Preheating in packaging machines.
- Acceleration of chemical reactions.
- P.T.E.F. treatments.
- Finishing of cars and under-sealing.
- Printed lamination.



Infrared Spectrum for OSC1000 model

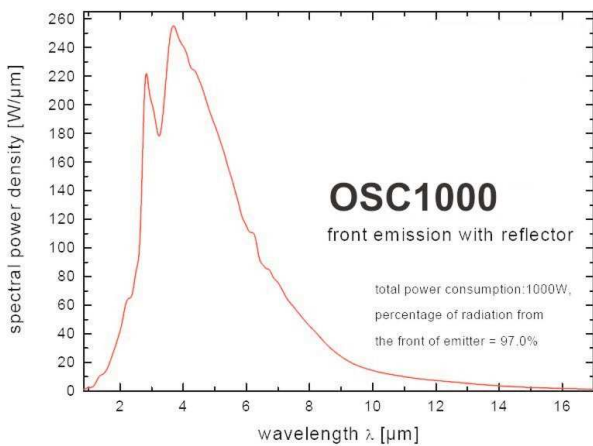

Heat Up Graph for OSC / OSCP / OSPG / OSPP models

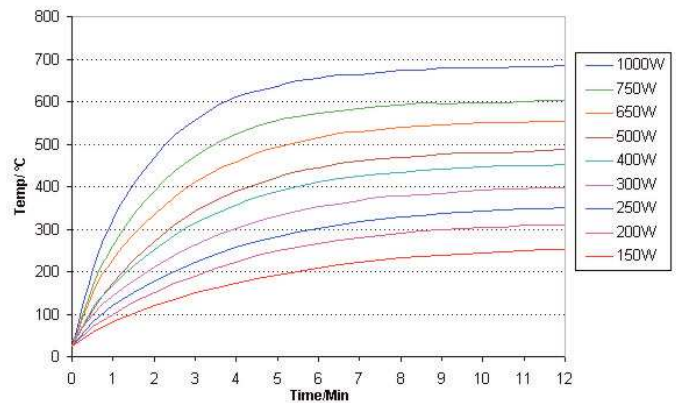

- Based on OSC test of average surface temperature with an infrared thermometer set at an emissivity of 0.9 (with the element mounted in an aluminised steel reflector OSCN)
- These temperatures also apply to the OSPG
- For OSCP divide the wattage by 2
- For OSPP divide the wattage by 4

RECTANGULAR CURVED OSC MODELS 245x60 mm

Code	Watts	Weight Kg
OSC200	200	0,23
OSC250	250	0,23
OSC300	300	0,23
OSC400	400	0,23
OSC500	500	0,23
OSC650	650	0,23
OSC750	750	0,23
OSC800	800	0,23
OSC1000	1000	0,23



RECTANGULAR CURVED OSCxxK MODELS 245x60 mm WITH BUILT-IN K TYPE THERMOCOUPLE

Code	Watts	Weight Kg
OSC250K	250	0,26
OSC400K	400	0,26
OSC500K	500	0,26
OSC750K	750	0,26
OSC1000K	1000	0,26

Common dimensions for models OSC and OSCxxK

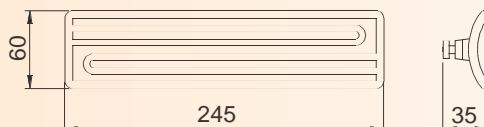

RECTANGULAR CURVED OSCP MODELS 122x60 mm

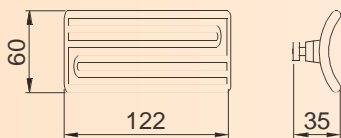

Code	Watts	Weight Kg
OSCP125	125	0,14
OSCP200	200	0,14
OSCP325	325	0,14
OSCP400	400	0,14
OSCP500	500	0,14



FLAT SQUARE OSPG MODELS 122x122 mm

Code	Watts	Weight Kg
OSPG250	250	0,24
OSPG400	400	0,24
OSPG650	650	0,24

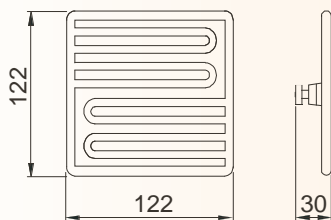

FLAT SQUARE OSPP MODELS 60x60 mm

Code	Watts	Weight kg
OSPP125	125	0,10
OSPP200	250	0,10

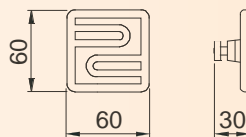

HOLLOW CERAMIC ELEMENTS

The Hollow offers the following advantages over conventional ceramic emitters:

- Heat up time reduced by over 40%
- Energy savings of over 15% in some applications
- Lightweight construction with low thermal mass.

The Hollow element is available in a range of Power ratings and voltages

The universal ceramic mounting allows it to be easily interchanged with a conventional emitter in an existing installation

Infrared Spectrum for OSH800 model

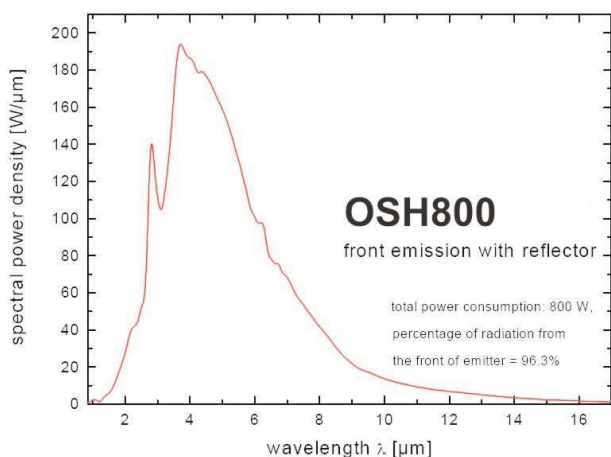

Heat Up Graph for OSH / OSHP / OSHC models

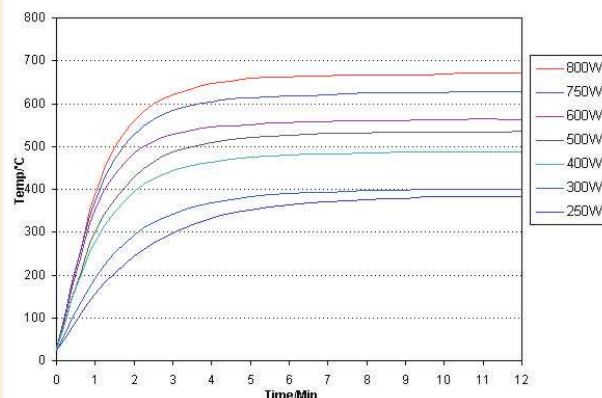

- Based on OSH test of average surface temperature with an infrared thermometer set at an emissivity of 0.9 (with the element mounted in an aluminised steel reflector OSCN)
- These temperatures also apply to the OSHC
- For OSHP divide the wattage by 2

FLAT RECTANGULAR OSH MODELS 245x60 mm

Code	Watts	Weight Kg
OSH250	250	0,28
OSH300	300	0,28
OSH400	400	0,28
OSH500	500	0,28
OSH600	600	0,28
OSH750	750	0,28
OSH800	800	0,28

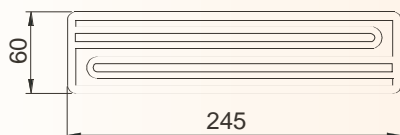
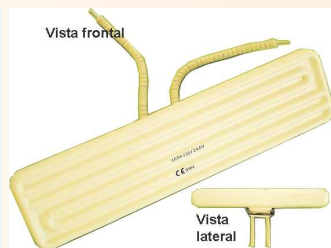

FLAT RECTANGULAR OSHP MODELS 122x60 mm

Code	Watts	Weight kg
OSHP125	125	0,16
OSHP200	200	0,16
OSHP250	250	0,16
OSHP300	300	0,16
OSHP400	400	0,16

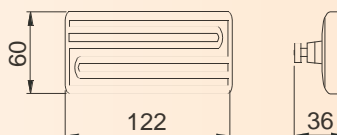

FLAT SQUARE OSHC MODELS 122x122 mm

Code	Watts	Weight Kg
OSHC250	250	0,27
OSHC300	300	0,27
OSHC400	400	0,27
OSHC500	500	0,27
OSHC600	600	0,27
OSHC800	800	0,27

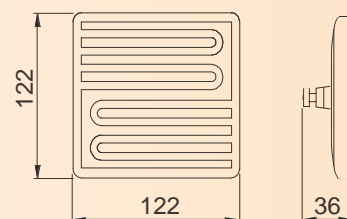

CERAMIC INFRARED BULB, BOS MODELS

The Ceramic Infrared Bulb is primarily used in the area of animal / pet healthcare. It is also robust in design and emits long wave infrared radiation in the range 2 - 10 µm. Normal installation is via an E27 Ceramic lamp holder and reflector unit (see our Accessories Section for further information.)

Dimensions BOS150 and BOS250 models

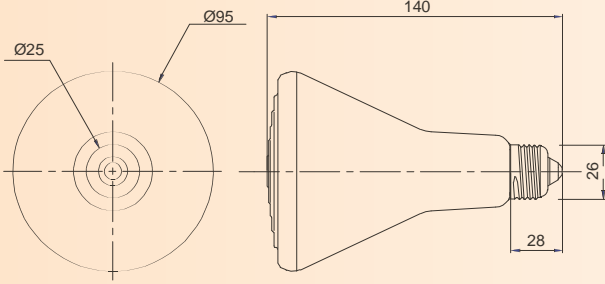

Heated side



Dimensions BOS60 and BOS100 models

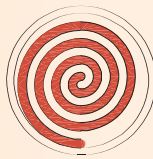
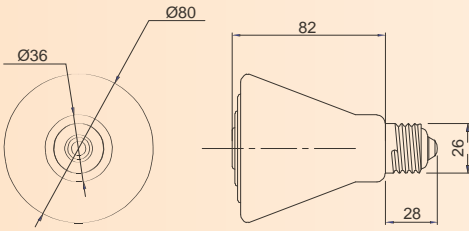

Heated side

Code	Watts	Dimensions in mm	Weight in Kg
BOS60	60	Ø80 x 110	0,14
BOS100	100	Ø80 x 110	0,14
BOS150	150	Ø95 x 140	0,20
BOS250	250	Ø95 x 140	0,20

Heat Up Graph for BOS models

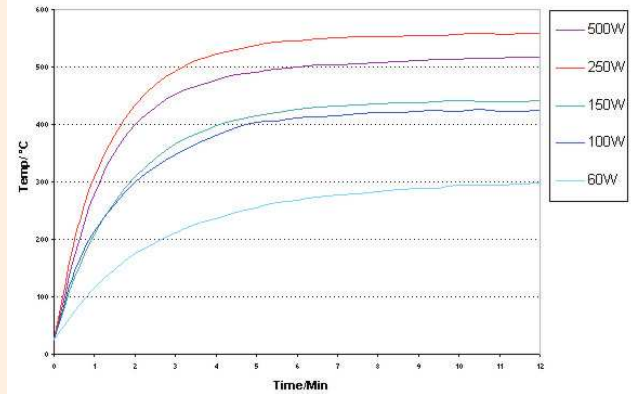

- Based on BOS test of average surface temperature with an infrared thermometer set at an emissivity of 0.9 (with the element mounted in an aluminised steel reflector PBOS)

ACCESSORIES FOR CERAMIC INFRARED EMITTERS

Steel reflectors for OSC / OSCxxK / OSCP / OSH / OSHP models

OSC-N

(With earth connection)



OSCS

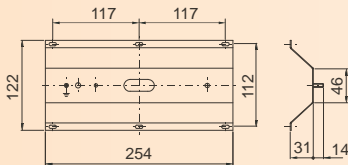
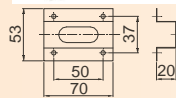

Código	Descripción	Peso en Kg
OSCS	Support	0,02
OSC-N	Screen 24 x 122 mm	0,12
PBOSP	Screen Ø210 x 140 mm	0,07
HBOS	Ceramic holder	0,20



IGRR

GROUP 6 - Infrared radiation equipment

General characteristics

- Tubular elements in stainless steel tube AISI 321 or 304L of Ø8 mm, insulated with electromelted and lamination-compressed magnesium oxide.
- Terminals BM4-P (Thread M4)
- Zinc-plated steel flange.
- Standard voltage ~230 V

Code	Volts	Watts	Electricfor's constructive thermic class
IGRR030	~230	300	T-700-T
IGRR045	~230	400	T-700-T

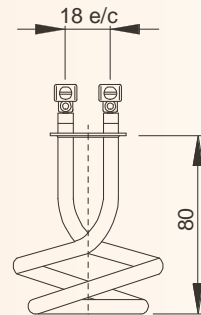



Quartz infrared panels provide infrared radiation in the medium wavelength range of 1.4 and 5.6 μm. They are favoured in industrial applications where rapid heat response is necessary. They are most cost effective in systems with long heat off cycles as they reach operating temperature in a matter of seconds.

They have a recommended radiation distance of 100 - 200 mm. The heaters can be installed in reflectors, projectors or panels for improved efficiency. In moving heaters arrangements the elements should be fitted with tubes at right angles to the direction of travel.

Usual applications

- Paint drying steel panels - Acrylic
- Paint drying steel panels - Epoxy
- PVC paste curing
- ABS forming
- Polystyrene forming
- Polyethylene forming
- Polypropylene forming
- Powder paint
- Pre-lacquering

General characteristics

The quartz infrared panels are composed of:

- Iron-chrome aluminium resistance wire.
- Parallel translucent quartz tubes.
- Highly reflective aluminised steel body that ensures a low loss of radiation from the back of the heater.

- Two M5 x 30 mm screws which extend from the rear of the heater.
- Supplied with 100mm ± 10mm ceramic beaded power leads.
- Element dimensions and design can be adjusted to suit customers heating requirements.
- Quartz elements can also be supplied with an in-built type K thermocouple.

Infrared Spectrum for PQR1000 model

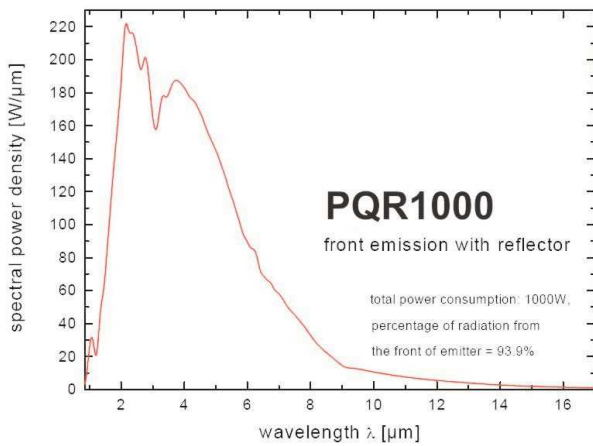

Heat Up Graph for PQR / PQP / PQC models

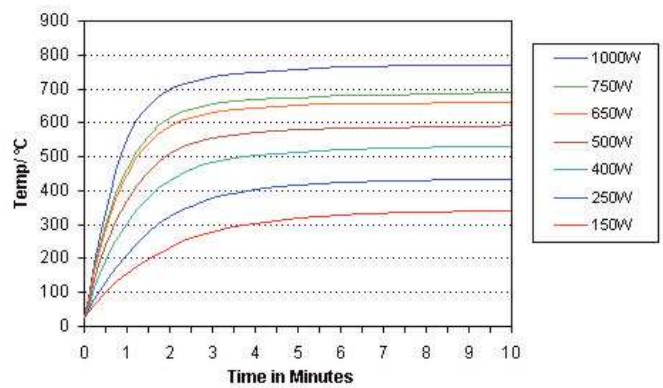

- Based on OSC test of average surface temperature with an infrared thermometer set at an emissivity of 0.7
- For PQP divide the wattage by 2
- For PQC divide the wattage by 4

QUARTZ INFRARED PANELS, MODELS PQR, 247 x 62,5 mm

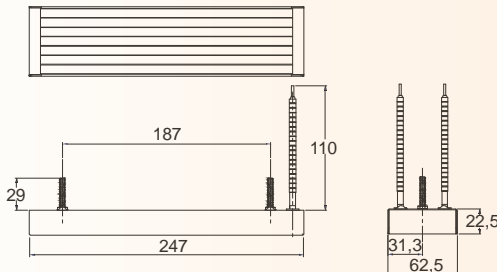

Code	Volts	Watts	W/cm ²	Average Surface Temperature	Wavelength	Weight in Kg
PQR150	~230 V	150	0,9	343 °C	1,5 a 8 μm	0,39
PQR250	~230 V	250	1,6	438 °C	1,5 a 8 μm	0,39
PQR400	~230 V	400	2,6	542 °C	1,5 a 8 μm	0,39
PQR500	~230 V	500	3,2	593 °C	1,5 a 8 μm	0,39
PQR650	~230 V	650	4,2	664 °C	1,5 a 8 μm	0,39
PQR750	~230 V	750	4,9	690 °C	1,5 a 8 μm	0,39
PQR1000	~230 V	1000	6,5	772 °C	1,5 a 8 μm	0,39

QUARTZ INFRARED PANELS, MODELS PQP, 123,5 x 62,5 mm

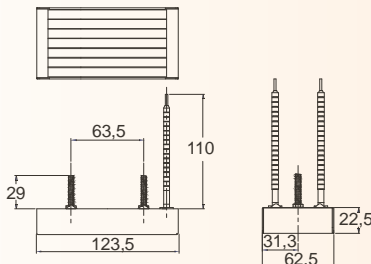

Code	Volts	Watts	W/cm ²	Average Surface Temperature	Wavelength	Weight in Kg
PQP150	~230 V	150	1,9	342 °C	1,5 a 8 μm	0,25
PQP250	~230 V	250	3,2	437 °C	1,5 a 8 μm	0,25
PQP400	~230 V	400	5,2	532 °C	1,5 a 8 μm	0,25
PQP500	~230 V	500	6,5	593 °C	1,5 a 8 μm	0,25

QUARTZ INFRARED PANELS, MODELS PQC, 62,5 x 62,5 mm

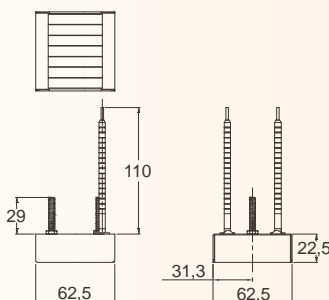

Code	Volts	Watts	W/cm ²	Average Surface Temperature	Wavelength	Weight in Kg
PQC150	~230 V	150	3,2	342 °C	1,5 a 8 μm	0,16
PQC250	~230 V	250	6,5	436 °C	1,5 a 8 μm	0,16



Immediate heat ... Whenever you need it

IC emitters mean heat can be directed precisely where it is needed. Rather than heating the air, IC emitters cross through it and only heat the areas required, working in a way similar to the sun. The immediacy of the heat eliminates pre-heating costs, resulting in substantial saving for users.

To optimise performance of IC emitters, we have developed a patented parabolic reflector, which is unique in the market. These reflectors are the result of extensive research to create a powerful, uniform and directional source of heat. Its features mean the IC heater line is one of the most efficient and powerful with the lowest consumption on the market.

The emitter lamp also has a special anti-reflection screen and emits a soft "sunset" effect to create a pleasant ambience.

Where IC emitters can be used

IC emitters provide heat to any area and can also be used in any kind of building or area where conventional heating systems cannot be used because of excessive costs or installation difficulties.

Ideal for zone heating:

- Homes, holiday homes
- Indoors and outdoors in working areas, garages
- Terraces, open air spaces
- Under parasols, viewpoints
- Restaurants, hotels, pubs and bars
- Exhibition centres



• SAVING

Immediate, focused, adjustable heat

• CLEAN AND SILENT ENERGY

Ecological, like the beneficial infrared rays of the sun: silent and non-pollutant

• EXTENSIVE HEATED AREAS

Large radiation angle and even transmission

• FLEXIBILITY

Modular and transferable system

How to install infrared emitters

On walls



Rectangular areas

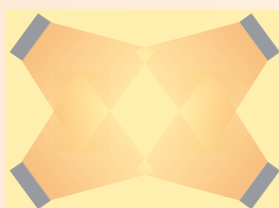

Alternate walls



On ceilings

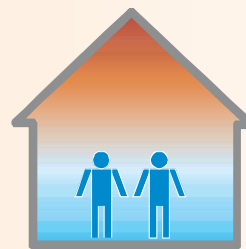
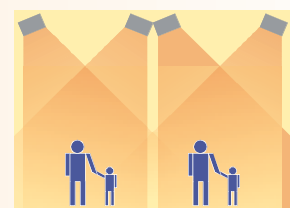

Traditional heating system

The hot air rises, stratifies and is dispersed through small air currents .

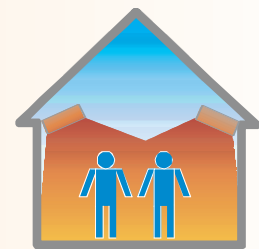

IC Infrared System

The heat is directed and is maintained at the same level on the areas required, the same as a spotlight.

• SIMPLE INSTALLATION

A single electric cable

• NO MAINTENANCE

Long-lasting IC lamp

• EXCLUSIVE DESIGN

Can be used in all environments and furniture





Code	Dimensions in mm	Weight
IC 1003	440 x 87 x 70	2 Kg
RL-IC1003	Spare part lamp for infrared IC1003. 220/240 V - 1500 W	0,15 Kg

Heating area

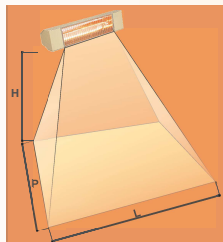

H = Height → 2 mts
 P = Depth → 3 mts
 L = Length → 4 mts

Test conditions (*):
 - Outdoor
 - Atmospheric temp: 10 °C
 - No wind

IP-X5 water resistant compact infrared heater, IC1003 model

- Directional model for installation on walls, low structures or under parasols.
- Available in hazel brown RAL 1035.
- Heating area:
 - 15 / 18 m² in indoor areas
 - 12 m² in outdoor areas
- IP-X5 water resistant
Withstands rain and is splash-proof
- 1500 W
220/240 V
50/60 Hz
- **Accessories included:**
 - Mounting support for wall installation or under parasols.
 - Electric input cable 1500mm long.
 - Protection grille
- **Recommended installation height:** 1'90 - 2'20 m high
- **Recommended installation position:** On the wall or under parasols
- **Ideal for:**
 - Areas at risk of rain or water splashes
 - patios
 - terraces
 - bathrooms
 - changing rooms



Code	Dimensions in mm	Weight
IC1013NG	400 x 130 x 215	3 Kg
RL-IC1013NG	Spare part lamp for infrared IC1013NG. 220/240 V - 2000 W	0,15 Kg

Zona de calentamiento

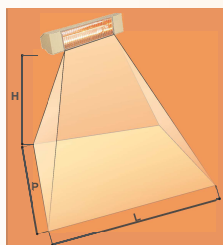

H = Height → 2,8 m
 P = Depth → 4 m
 L = Length → 4 m

Test conditions (*):
 - Outdoor
 - Atmospheric temp: 10 °C
 - No wind

IP-X5 water resistant compact infrared heater, IC1013NG model

- Directional model for installation on walls or under parasols.
- Available in hazel brown RAL 1035 with light grey border.
- Heating area:
 - 20 / 25 m² in indoor areas
 - 16 m² in outdoor areas
- IP-X5 water resistant
Withstands rain and is splash-proof
- 2000 W
220/240 V
50/60 Hz
- **Accessories included:**
 - Mounting support for wall installation or under parasols.
 - Electric input cable 1500mm long.
 - Protection grille
- **Recommended installation height:** 2.10 - 2.50 m high
- **Recommended installation location:** On the wall or under parasols
- **Ideal for:**
 - Areas at risk of rain or water splashes
 - patios
 - terraces
 - bathrooms
 - changing rooms



Code	Dimensions in mm	Weight
IC 1007	375 x 215 x 170	3 Kg

Heating area

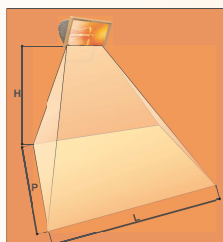

H = Height → 2 mts
 P = Depth → 3 mts
 L = Length → 3 mts

Test conditions (*):
 - Outdoor
 - Atmospheric temp: 10 °C
 - No wind





IP-54 water resistant compact infrared heater, IC1007 model

- Wall installation directional model
- Available in black with hazel brown border RAL 1035
- Heating area: 10 m²
- IP-54 water resistant
Withstands rain and is splash, humidity and dust- proof
- 1300 W
220/240 V
50/60 Hz
- **Accessories included:**
 - Mounting support for wall installation.
 - Electric input cable 1500mm long.
- **Recommended installation height:** 1.90 - 2.10 m high
- **Recommended installation location:** Wall
- **Ideal for:**
 - Working areas exposed to splashes of water and dust.
 - patios
 - quarries
 - garages
 - farms

(*) **Note:** The heating area test data may vary depending on the installation height, weather conditions and interaction between other infra-heaters installed. In this case the results of the heat produced may be significantly higher.



IP-54 water resistant compact infrared heater, IC1008 model

-  Model for floors
-  Available in black with hazel brown border RAL 1035
-  Heating area: 10 m²
-  IP-54 water resistant
Withstands rain and is splash-proof
-  1300 W
220/240 V
50/60 Hz

- **Accessories included:**
 - Protective grille.
 - Electric input cable 3000mm long.
 - Stand for floor.
- **Recommended installation position:** on the ground
- **Ideal for:**
 - Working areas exposed to splashes of water and dust.
 - patios
 - quarries
 - garages
 - farms



Heating area

Approx. heating surface area: 10 m²



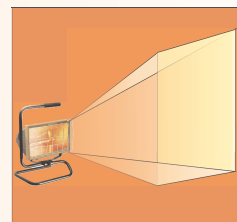

Test conditions (*):

- Outdoor
- Atmospheric temperature: 10 °C
- No wind



Code	Dimensions in mm	Weight
IC 1008	350 x 300 x 500	4 Kg

IP-X5 water resistant compact infrared heater, IC1014FM model

-  Stand model.
-  Available in anthracite black
-  Heating area: 20 m²
-  IP-X5 water resistant
Withstands rain and is splash-proof
-  2000 W
220/240 V
50/60 Hz

- **Accessories included:**
 - Stand
 - Electric input cable 5000mm long with Schuko type plug
 - Protection grille.
- **Recommended installation height:** 2.10m high
- **Ideal for:**
 - Areas at risk of rain or splashes of water
 - patios
 - terraces
 - bathrooms
 - changing rooms

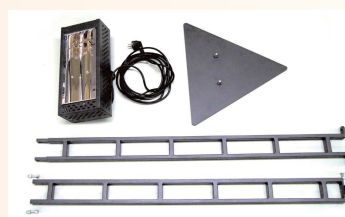

Heating area

H = Height → 2,1 m
P = Depth → 4,5 m
L = Length → 4,5 m

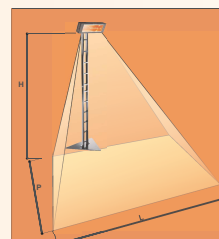





Test conditions (*):

- Outdoor
- Atmospheric temp: 10 °C
- No wind

Code	Total height 211 cm	Weight
IC 1014FM		16 Kg

Infrared ATEX certified, ICSAFE models

-  Adjustable wall mounted model.
-  Available in grey colour (RAL7015)
-  Heating area: 10-12 m²
-  IP-66 water resistant
Withstands rain and is splash-proof
- **General characteristics:**
 - Quartz halogen element with gold reflector.
 - Parabolic reflector designed for maximum radiation output.
 - Robust painted steel housing.
 - Class I electric device

- **Recommended installation height:** 2,10 mts
- **ATEX Identification:**
 - Ex nA IIC T2 Gc
 - ICSAFE20 - Ex tc III C T290°C Dc IP66 -5°C ≤ Ta ≤ T25°C
 - ICSAFE15 - Ex tc III C T230°C Dc IP66 -5°C ≤ Ta ≤ T25°C



Heating area

H = Height → 2, m
P = Depth → 3 m
L = Length → 3 m

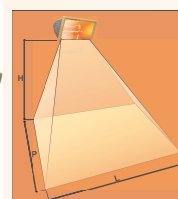

Test conditions (*):

- Outdoor
- Atmospheric temp: 10 °C
- No wind

Code	Volts	Watts	Dimensions in mm	Weight
ICSAFE15	220 - 240 V _{ac}	1500	535x270x200	9,2 Kg
ICSAFE20	220 - 240 V _{ac}	2000	535x270x200	9,2 Kg



Presence detector, IC2003 model

Special accessories to detect temporary presence of people in areas such as changing rooms, restaurants, meeting rooms, etc. Wall or ceiling installation.

- Maximum recorded power: 3.0 KW
- Colour: black
- Measurements: 15x15x8 cm

Code	Maximum recorded power	Weight
IC 2003	3000 W	0,3 Kg

(*) **Note:** The heating area test data may vary depending on the installation height, weather conditions and interaction between other infra-heaters installed. In this case the results of the heat produced may be significantly higher.



Ceramic heater without metallic cover. The resistive wire is situated in several holes and protected at the ends to avoid moving. Connections are located in the plugged head.



General characteristics

- Heating elements with exposed coil of Nickel-Chrome alloy.
- Density load: 22 W/cm²
- Maximum superficial temperature: 650 °C
- Connections: plug-in ceramic header
- Standard voltage: ~220 V

Usual applications

- Warm air guns.
- Industrial dryers.
- Electric ovens.
- Heating of gas medium.
- Welding and shrink plastic ovens

Code	Description	Watts	Dimensions in mm						Weight in Kg
			ØA	ØB	C	D	ØE	ØF	
550201001	RCAPAC-001	280/350	28	26	105	130	4	19	0,10
550202001	RCAPAC-002	350/400	28	26	105	130	4	19	0,10
550203001	RCAPAC-003	500/500	28	26	105	130	4	19	0,10
550205001	RCAPAC-005	2200/2800	30	47	175	205	7	20	0,38

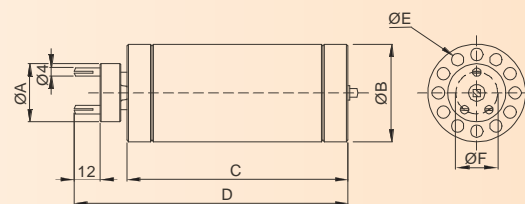

The ACN night heat accumulators range is designed to implement a totally independent heating system, meeting the most demanding heating needs in a most rational and economic way.

The ACN accumulators are easy to install, without the need for brickwork, tubes, chimneys or central appliance room.

You can benefit from a totally silent heating system (no fan), automatic and with no maintenance.

We can also comment on the great benefits of using electric night rate:

Night rate meter use:

- The night rate used for heat storing has up to a 55% discount on the day rate.

NO night rate meter use:

- By using the heat storing system you can maintain your room all day at the desired temperature, without the need for requesting additional power.

How it works: After turning on at the start of the night rate, the accumulator starts consuming the necessary power to restore the heat used the day before. At the end of the night rate, and after automatically turning off, the stored heat is used to maintain the proper temperature for the rest of the day.

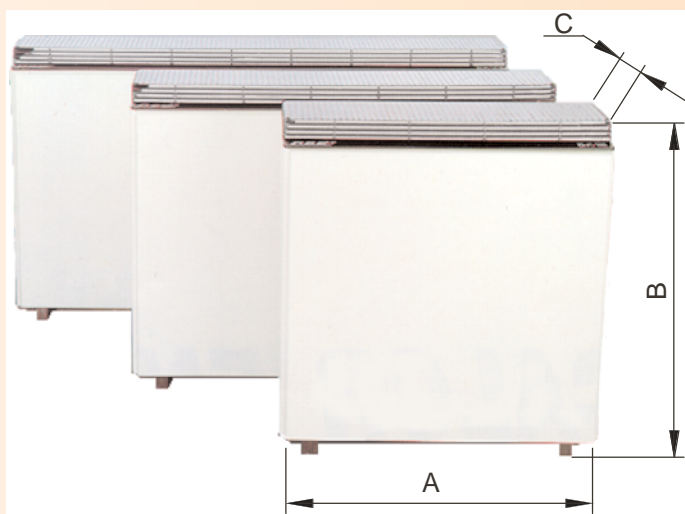

Technical data

Code	ACN1,5	ACN2,25	ACN3
Nominal load	1,5 kW	2,25 kW	3 kW
Storage 8 h.	11,2 kW	16,8 kW	22,4 kW
Maximum output	770 W	1100 W	1410 W
Minimum output	245 W	330 W	495 W
Average life	15,5 h	15,4 h	15,5 h
Total weight	70 Kg	100 Kg	130 Kg
Weight without bricks	14 Kg	19 Kg	24 Kg
Number of bricks	8	12	16
Finishes	Beige front panel. Black grid aluminium top.		

Code	Volts	Watts	Dimensions in mm			Weight kg
			A	B	C	
ACN1,5	~230	1500	522	570	159	70
ACN2,25	~230	2250	752	570	159	100
ACN3	~230	3000	982	570	159	130

MULTI USE ELECTRICAL AIR HEATERS. ANB MODELS: MOBILE OR WALL INSTALLATION

Model ANB3,6 is only for mobile use or fixed installation at 1'8m minimum height. The rest of the range of ANB air heaters are for mobile use or fixed installation at any height of the wall. If the ANB air heater is used as mural, it will fix on with the corresponding accessory. The wall fixing accessory allows the heater to be orientated in any direction thanks to its rotating capability up to 180°



- The ANB electric air heater complies with EN 60335-1 norm and its correspondent 2-30.
- The ANB is a Class I electrical apparatus. Model ANB3'6 is monophase supply with earth connection. Model ANB3'6SN is three-phase supply with earth connection. Other models are three-phase supply with neutral and earth connection.
- The ANB can be used as a mobile unit or as a fixed unit at any height of the wall
- It allows the heat to be directed vertically or horizontally with the wall fixed accessory.

General characteristics

- Wide operation possibilities that allow optimisation according to working conditions: from one to three heating stages plus one single ventilation function
- Room temperature selector. (Max approx. 39 °C)
- All models with hose cable (Long. 1'7 ms ANB3'6 - 6 - 9 and long. 2'1 m ANB12 - 17) and attachment plug type CETAC for the three-phase models and Schuko type of 16 A for model ANB3'6.

- 5 Vertical positions.
- The wall fixed accessory allows horizontal directioning of air heater in any direction owing to its capacity of swivelling 180°
- Manual reset over-temperature switch-off.
- Protecting grids that eliminate the risk of direct contact with the fan or indirect contact with the heater shield.
- Automatic function that eliminates the inertial heat of heating elements.
- Internal insulation chamber.

Model	Air flow m³/h (free discharge)	Heating power		Operating voltage V	Sound pressure level db	Operation					Weight in Kg	
		Kw	Kcal/h			0	I	●	●●	●●●	No case	case
						Stop	Ventilation	1/3 Heating power	2/3 Heating power	Full Heating power		
ANB3,6	210	3,6	3100	~230	~50	According to operation	According to operation	—	2400 W	3600 W	8,3	9,7
ANB3,6SN	210	3,6	3100	3 ~ 400	~50			1200 W	2400 W	3600 W	8,3	9,7
ANB6SN	465	6	5160	3 ~ 400	~50			2000 W	4000 W	6000 W	10,5	13,2
ANB6	465	6	5160	3N ~ 400	~50			2000 W	4000 W	6000 W	10,5	13,2
ANB9	975	9	7740	3N ~ 400	~45			3000 W	6000 W	9000 W	11,95	15,05
ANB12	1390	12	10320	3N ~ 400	~50	4000 W	8000 W	12000 W	17,75	22,55		
ANB17	1390	17	14620	3N ~ 400	~50	5666 W	11333 W	17000 W	18,7	23,5		

Model	Dimensions in mm						
	A	B	C	D	E	F	G
ANB3,6	220	338	172	349	274	445	1700
ANB3,6SN	220	338	172	349	274	445	1700
ANB6SN	268	388	192	360	324	470	1700
ANB6	268	388	192	360	324	470	1700
ANB9	320	440	192	408	374	545	1700
ANB12	366	486	285	470	420	625	2100
ANB17	366	486	285	470	420	625	2100

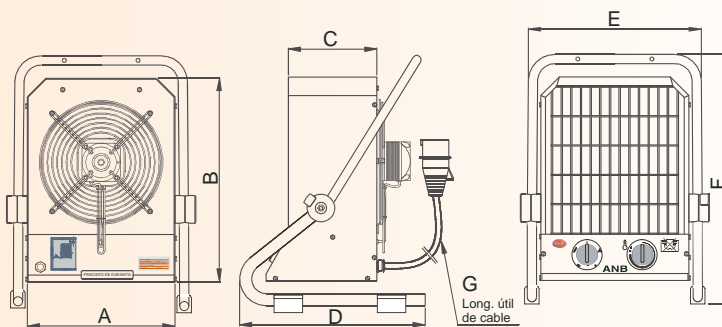

WALL FIXED ACCESSORY FOR ANB MODELS



The wall fixed accessory will allow you to easily install your ANB blow heater on the wall of your premises. Its 180° horizontal turning support together with the 5 different vertical orientation positions allows the current of hot air supplied by the ANB to be directed in the direction that you want.

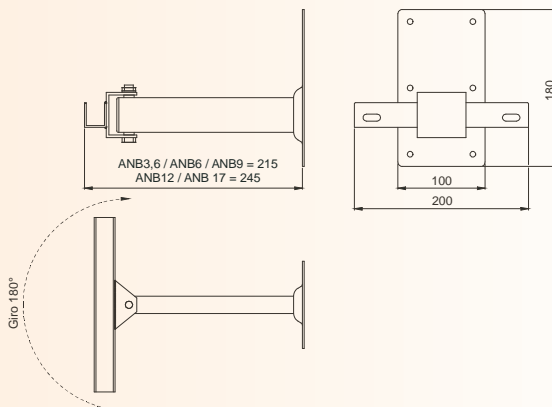

Code	Description	Weight in Kg	
		No case	Case
129098000	Wall fixed accessory for ANB3'6, ANB3'6SN, ANB3'6B, ANB6, ANB6SN and ANB9	1,06	1,21
129130000	Wall fixed accessory for ANB12 and ANB17	1,02	1,29



ELECTRICAL AIR HEATERS. MODELS RMO and RMOB. MURAL HIGH LEVEL FIXED INSTALLATION

High level fixed installation: Is a installation with a level not lower that 1,8 m above ground level, according to EN-60335-2-30.

General characteristics

- Fixed device high level wall installation.
- Advanced design casing, finished with paint dried at 150 °C.
- By means of a simple action on the side handle you can vertically orientate the heater in four fixed positions.
- Protective front grill.
- Silent ventilator.
- Hot or cold air indicator.
- Safety manual reset thermostat.
- Ventilator motor integrated in the cabinet, with protective mesh preventing acces to blades.
- Integrated earth connection.
- Maximum room temperature recommended: 40 °C
- All models, except the RMO4 and RMO4A, are fitted with air temperature thermostat connection and switch operation connection.
- RMO4 and RMO4A models are fitted with connection cable 1100 mm long.
- The RMO range incorporates NiCr wire alloy spiral batteries.
- The RMOB range incorporates stainless steel tubular elements batteries.



- The RMOB models incorporate an automatic function that after air temperature thermostat or safety thermostat shutdown, keeps the fan running while the heating elements are still hot.
- The complete range of RMO electric unit heaters, excepting models RMO4 and RMO4A, allows a wide range of tailor-made automatic functions to be programmed using the junction box:
 - Temperature control using a external air temperature thermostat. (Consult our catalogue División Forcosa nº 927)
 - Control of working times using a timer. (Consult our catalogue División Forcosa nº 927)
 - Control of various air heaters through one single device...

MODELS RMO

Code	Air flow m³/h (free discharge)	Heating power		(*) Operating voltage V	Sound pressure level db	No Switches	Operation				Voltage change options	Recommended height in mts.	Weight Kg
		KW	Kcal/h				Fan	1º	Heat 2º	kW 3º			
RMO4	430	3,6	3100	~ 230	≈50	3		Yes	1,8	1,8	---	1,8 to 2	7,7
RMO4A	430	3,6	3100	2 ~ 400	≈50	3	Yes		1,8	1,8	---	1,8 to 2	7,7
RMO6	690	6	5160	3 ~ 400 Δ	≈50	2	Yes	6	-	-	~ 230 3 ~ 230 Δ 3 ~ 400 Δ	1,8 to 2,2	9,7
RMO9	875	9	7740	3 ~ 400 Δ	≈55	2	Yes	9	-	-	3 ~ 230 Δ 3 ~ 400 Δ	2 to 2,5	16,6
RMO13,5	1490	13,5	11610	3N ~ 400 Δ	≈60	2	Yes	13,5	-	-	3 ~ 230 Δ 3 ~ 400 Δ 3N ~ 400 Δ	2 to 3	23,8
RMO18	1490	18	15480	3N ~ 400 Δ	≈60	2	Yes	18	-	-	3 ~ 230 Δ 3 ~ 400 Δ 3N ~ 400 Δ	2 to 3	24,3

MODELS RMOB

Code	Air flow m³/h (free discharge)	Heating power		(*) Operating voltage V	Sound pressure level db	No Switches	Operation				Voltage change options	Recommended height in mts.	Weight Kg
		KW	Kcal/h				Fan	1º	Heat 2º	kW 3º			
RMOB6	690	6	5160	3N ~ 400 Δ	≈50	2	Yes	6	-	-	~ 230 3 ~ 230 Δ 3N ~ 400 Δ	1,8 to 2,2	10,9
RMOB9	875	9	7740	3N ~ 400 Δ	≈55	2	Yes	9	-	-	3 ~ 230 Δ 3N ~ 400 Δ	2 to 2,5	18,1
RMOB13,5	1490	13,5	11610	3N ~ 400 Δ	≈61	2	Yes	13,5	-	-	3 ~ 230 Δ 3N ~ 400 Δ	2 to 3	26
RMOB18	1490	18	15480	3N ~ 400 Δ	≈61	2	Yes	18	-	-	3 ~ 230 Δ 3N ~ 400 Δ	2 to 3	26,5

(*) The electric air heater is supplied connected to the operating voltage indicated. See table for options for change voltage

Dimensions of the air heaters RMO and RMOB

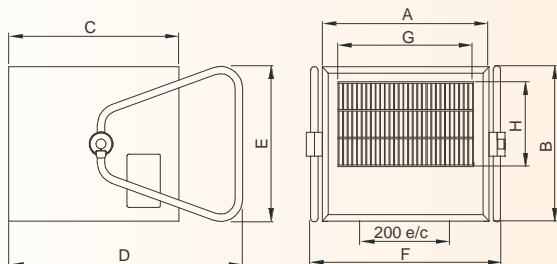

Code	Dimensions in mm							
	A	B	C	D	E	F	G	H
RMO4	302	245	209	398	319	371	274	217
RMO4A	302	245	209	398	319	371	274	217
RMO6 / RMOB6	302	245	260	398	319	371	274	217
RMO9 / RMOB9	400	288	380	442	319	469	371	257
RMO13,5 / RMOB13,5	412	383	443	540	382	481	336	228
RMO18 / RMOB18	412	383	443	540	382	481	336	228

WALL SUPPORT FOR RMO and RMOB

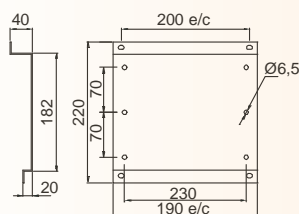

Code	Description
129475000	Wall fixed accessory for RMO and RMOB ranges

NOTE: Wall support kit includes all necessary accessories for its installation

GAP

Models as per catalogue: NTC-1502



GROUP 7 - Industrial heating units

7.4 - Air heaters

- The GAP electric air heater complies with EN 60335-1 norm and its correspondent 2-30.
- The GAP is a Class I electrical apparatus with ~230 V supply with earth connection

General characteristics

- Wide operation possibilities that allow optimisation according to working conditions: Two heating stages plus one single ventilation function
- Room temperature selector. (Max approx. 35 °C)
- With hose cable long. 1'5 mts and attachment plug type Schuko 16 A.
- Manual reset over-temperature switch-off.
- Protecting grids that eliminate the risk of direct contact with the fan or indirect contact with the heater shield.
- Automatic function that eliminates the inertial heat of heating elements.
- Internal insulation chamber.
- Degree protection against moisture IP-44
- Marked

Technical characteristics and dimensions

Model	Flowrate m³/h	Heating power		Volts V	Sound pressure level db	Operation				Weight Kg
		Kw	Kcal/h			Stop	Only ventilation	Heating step nº 1	Heating step nº 2	
GAP3,6	272	3,6	3100	~230	≈50	Si	Si	2000 W	3600 W	7,7

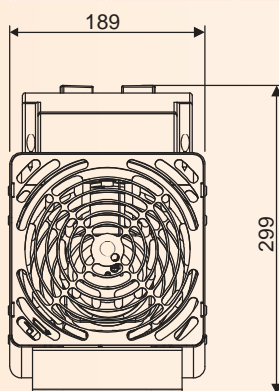
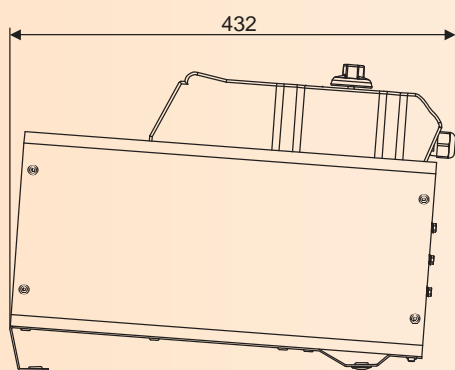

Handling controls GAP3,6

- 1 - Comfort temperature selection button
- 2 - Operation button selector
- 3 - Manual reset

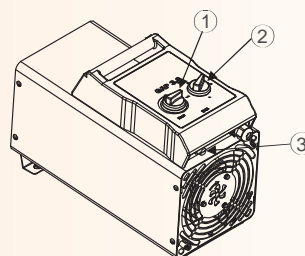

RAD

Models as per catalogue: NTC-1501



GROUP 7 - Industrial heating units

7.5 - Aluminum injected emitters

Technical characteristics

- Aluminum injected emitters with thermal oil.
- Class I electrical apparatus with ~230 V supply
- Stainless Steel heating elements.
- Enough aluminum elements to make the surface temperature adequate.
- Ambient temperature control thermostat and total safety with thermal fuse.
- Supports to install the emitter on the wall. Minimum high level installation: 150mm. Materials optimized to avoid dilation sounds.
- easy operation
- Marked

Technical characteristics and standard models at ~230 V

Code	Nº elements	Nº supports	Power	Area in m² that is able to heat, depending on the climatic zone and the insulation of the building. Maximum height 2,5m
RAD-5-600	5	2	600 W	10 to 16 m²
RAD-7-900	7	2	900 W	15 to 24 m²
RAD-9-1200	9	2	1200 W	20 to 32 m²
RAD-12-1500	12	2	1500 W	30 to 40 m²
RAD-15-2000	15	3	2000 W	37 to 54 m²

- It is recommended to place an ambient thermometer⁽¹⁾ in each room or in the main rooms.
- The part of the house more energy absorb are the walls. Therefore, we recommended to maintain the temperature during the day, in the moments of absence, five degrees below the desired one, which should oscillate at 17 °C and 20.5 °C.

(1) - See bimetallic thermometers in our General program of thermostats and thermometers

- Important discounts on the P.V.P

- Rappel by number of ordered elements

Dimensions and weight

Code	Dimensions in mm (wide x high x depth)	Weight Kg
RAD-5-600	460 x 565 x 94	7,8
RAD-7-900	612 x 565 x 94	10,4
RAD-9-1200	770 x 565 x 94	13,2
RAD-12-1500	992 x 565 x 94	17,2
RAD-15-2000	1220 x 565 x 94	21,3



HOT-AIR CURTAINS, COR MODELS

Keeping doors open leads to considerable energy costs in most buildings. The proper installation of an air curtain can reduce energy lost through open doors by 90%. In addition to the considerable energy saving, the curtains improve the healthiness in the environment and make it possible to keep doors open even in winter, which makes it easier for customers to go into commercial stores.

COR air curtains come in three lengths of 900, 1200, and 1500 mm, which can be fitted alongside each other to adapt to any door width on industrial or commercial premises. All the curtains include a remote-control handset.



General characteristics

- Metal casing
- Several sizes from 90 to 150 cm
- Controlled by microprocessor
- Remote control
- High speed
- Maximum air renewal
- Low noise level
- Single-phase or three-phase supply voltage of ~220 V and 3-380 V respectively

Why an air curtain?

Open doors and store entrances create energy loss, as well as causing air-current problems. Installing an air curtain can reduce energy loss and improve comfort levels. There are three factors that affect the air current passing through an open door:

- Difference between interior and exterior pressure. The difference between interior and exterior pressure can be eliminated by using balanced ventilation.
- Difference between interior and exterior temperature. Hot air is less dense than cold air. This means that cold air from outside penetrates the entrance at the bottom part of the opening, pushing the hot air outside through the top part of the opening. This exchange of air is caused by thermal currents and is due to the fact that masses of cold and hot air have different densities.
- Wind speed against the opening. The flow of air passing through the entrance is strengthened by the effect of the wind. If we were to assume that the wind blows uniformly through the entire opening, after a while, the store would have an overpressure so great that the air current would be limited to what is filtered outside through the cracks in the buildings.

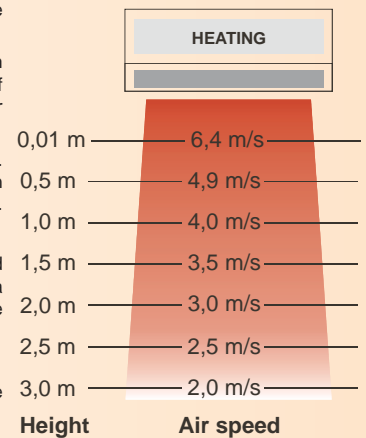

FITTING AIR CURTAINS

An air curtain creates an effective barrier at the entrance, preventing cold air penetrating from the outside. The air speed of the curtain must be enough for the resulting air to be directed downwards. The air curtain should be placed so that a small part of the air current is directed outside the opening, while the rest blows inside. In this way, the cold air outside stays outside of the barrier, while the warm air inside stays inside.

POSITION

For the best possible result, the air curtains must be fitted as close as possible to the opening, and should take up the entire width of the entrance.

POTENTIAL ENERGY SAVING

The potential energy saving depends on the height of the door. Measurements show that when doors up to 3.5 high are used, the air curtains reduce energy loss by about 90%. For doors higher than 3.5 m, the savings decrease consistently in proportion to the height of the door. For doors 7 m high, the potential energy saving is reduced to approximately 30%. The following graph shows the correlation:

Normal energy saving with hot-air curtain



The graph shows us that by fitting air curtains on a 5 m high door it is possible to reduce energy loss by approximately 75%.

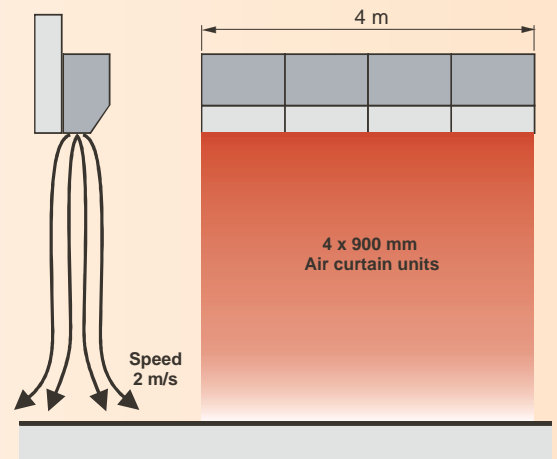

Fitting hot-air curtains

Standard models

Code	Model	Air flow (m³/h)	Heating power (KW)	Operating voltage V	Nº speeds	Applicable height (m)	Ventilation consumption W	Heating consumption W	Control	Noise level (dB)	Dimensions in mm			Weight kg
											Height	Width	Depth	
EC06483	09/6R	912	6	~220	2	3	96 / 156	6156	Remote and manual	55	221	900	183	15,5
EC06484	12/8R	1280	7,2	~220	2	3	126 / 178	7378		57	221	1200	183	19,5
EC06485	15/8R	1670	9	~220	2	3	154 / 207	9207		59	221	1500	183	23,5
EC06486	09/6R3	912	6	3 ~ 380	2	3	96 / 156	6156		55	221	900	183	15,5
EC06487	12/8R3	1280	7,2	3 ~ 380	2	3	126 / 178	7378		57	221	1200	183	19,5
EC06488	15/8R3	1670	9	3 ~ 380	2	3	154 / 207	9207		59	221	1500	183	23,5





ELECTRIC AIR HEATERS, FUH RANGE

Descripción

The FUH range of flame proof electric unit air heaters offer a Hazardous Area, space heating solution, for large premises requiring high heating capacity. They are certified for use in Zone 1 and Zone 2 areas where the flammable atmosphere is a Group IIA, IIB or IIC Gas

Typical Applications

- Oil Refineries
- Petrochemical Plant
- Coal Mines
- Offshore Platforms
- Ammunition Stores
- Sewage Plants
- Paint Stores

General characteristics

- Efficient liquid to air heat exchanger
- Over-temperature protection
- Adjustable angle outlet louvres.
- Optional, integral room temperature control thermostat.
- **Certification:** Certificado ATEX EEx"d" IIC T3, según EN 50014 y EN 50018
- **Heating elements:** Rod type heating elements comprising 80/20 Nickel chrome resistance wire, compacted high purity Magnesium Oxide insulating powder and encased in Incoloy 825 metal sheath.
- **Controls:** Liquid temperature control thermostat. Liquid temperature, manual reset, safety thermostat. Optional: Return air temperature control thermostat
- **Voltage:** Heater and Motor - Standard 3 phase (4 wire) supplies, with possibility of connecting from 3N-380 V to 3N-480 V. In the attached picture the powers corresponding to the assigned voltages. Controls - Up to 240v single phase

Standard models

Model	Heating power according to supply					Air flow (m³/h)	Weight in Kg
	3N-380 V	3N-400 V	3N-415 V	3N-440 V	3N-480 V		
FUH9	7 kW	8,25 kW	9 kW	10 kW	12 kW	1188	120
FUH12	10 kW	11 kW	12 kW	13 kW	16 kW	2463	120
FUH15	13 kW	13,75 kW	15 kW	17 kW	20 kW	2463	145
FUH20	17 kW	18,4 kW	20 kW	23 kW	27 kW	5096	145
FUH30	25 kW	27,5 kW	30 kW	--	--	5096	145

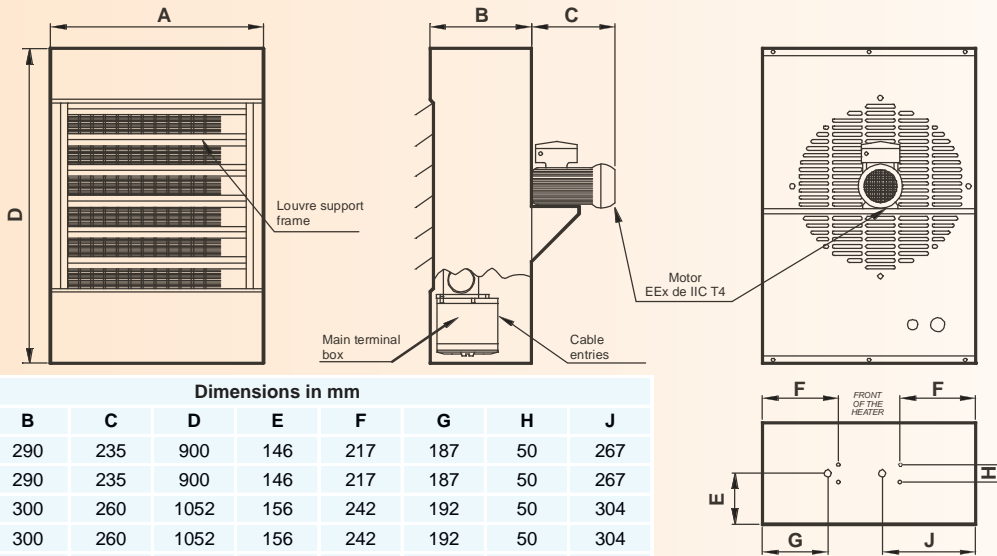

Model	Dimensions in mm								
	A	B	C	D	E	F	G	H	J
FUH9	610	290	235	900	146	217	187	50	267
FUH12	610	290	235	900	146	217	187	50	267
FUH15	760	300	260	1052	156	242	192	50	304
FUH20	760	300	260	1052	156	242	192	50	304
FUH30	760	300	260	1052	156	242	192	50	304

Wiring diagram

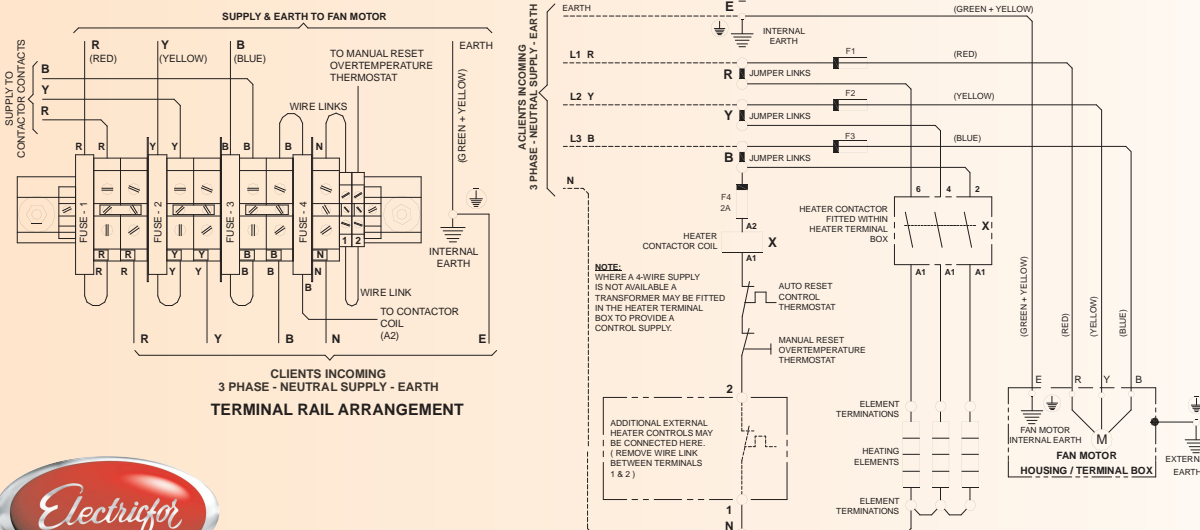

THREE-PHASE INDUSTRIAL CONVECTORS, MODELS RIS

General characteristics

- Class I electrical device
- Zinc-plated steel chassis.
- Connection box in zinc-plated steel with degree protection against moisture IP54.
- If you require, we can supply the RIS industrial convectors with connection box and chassis in stainless steel.
- Metallic stuffing box.
- Tubular elements in stainless steel tube AISI 321 or 304 with aluzinc fin of 25 x 50 mm.
- Models RIS1,5T and RIS3T with three-pole thermostat of control and safety.
- High resistance to impact, rough handling and water or oil splashes.
- Standard voltage 3~230 Δ 3~400 V Ƶ

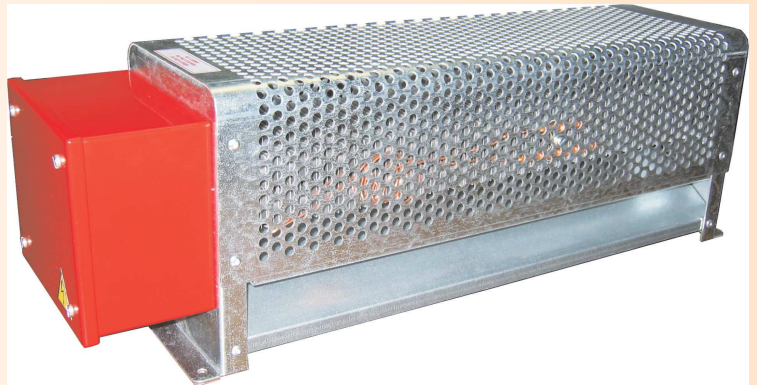

Standard models

Code	Volts	Watts	Dimensions in mm			Weight in kg
			A	B	C	
RIS1,5	3~230 Δ 3~400 Ƶ	1500	380	310	290	5,4
RIS1,5T(*)	3~230 Δ 3~400 Ƶ	1500	380	310	290	5,5
RIS3	3~230 Δ 3~400 Ƶ	3000	620	550	530	7,6
RIS3T(*)	3~230 Δ 3~400 Ƶ	3000	620	550	530	7,7

(*) Models with built in thermostat. See characteristics in table

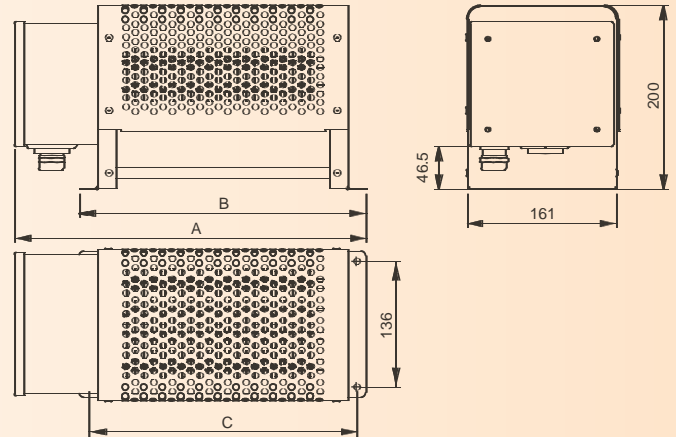

THREE-POLE THERMOSTAT FOR RIS INDUSTRIAL CONVECTORS

Control and safety three-pole thermostat with two bulbs of Ø6,5x95 and Ø6,5x29 mm. 20 A ~230 V 15 A ~400 V	Code	Operation as control thermostat with automatic reset. Temperature range	Operation as safety thermostat with manual reset. Safety temperature
		122015000	13 °C to 83 °C ±7 °C

MONO-PHASE INDUSTRIAL CONVECTORS, MODELS CIE

General characteristics

- Class I electrical device
- Zinc-plated steel chassis
- Adjustable aluminium box with degree protection against moisture IP66.
- If you require, we can supply the CIE industrial convectors with connection box and chassis in stainless steel.
- Connection cable 3x1,5 mm² and 1500 mm long, with connection plug of 16 A type Schuko.
- Metallic stuffing box.
- Tubular elements in stainless steel tube AISI 321 or 304 with aluzinc fin of 25 x 50 mm.
- High resistance to impact, rough handling and water or oil splashes.
- Standard voltage ~230 V



Standard models

Code	Volts	Watts	Dimensions in mm			Weight in Kg
			A	B	C	
CIE1	~ 230	1000	620	570	550	3,5
CIE1,5	~ 230	1500	880	830	810	4,8
CIE2	~ 230	2000	1120	1070	1050	5,7

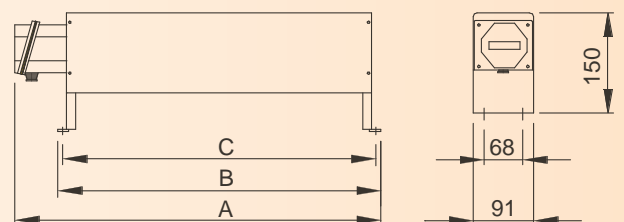

HOT-AIR CONVECTORS, FAW RANGE

The 'FAW' range of hot-air convectors was designed to heat small working areas, storage areas, or similar applications, located in hazardous areas classified as Zone 1 or Zone 2, where the flammable atmosphere is Gas Group IIA, IIB, or IIC.

Common applications

- Aircraft hangers
- Chemical plants
- Oil platforms
- Petrol service stations
- Gas facilities

General characteristics

- LCIE Certificate ATEX Ex II 2 G EEx'e' IIC T2 to T4, in accordance with EN 50014 and EN 50019
- Terminal box with damp protection grade IP66 / IP67
- Available for temperature classification T2, T3, and T4.
- Ambient temperature range from -20 °C to +60 °C. • Treated-steel or stainless-steel chassis.
- **Terminal box:** Aluminium box with Ø20 mm input for cables. Additional cable inputs will be implemented on request.
- **Heating components:** Tubular elements with fins that can be replaced individually, fabricated with NiCr 80/20 alloy resistive wire, compacted magnesium oxide, and tubular stainless-steel sleeve.
- **Controls:** If necessary, FAW hot-air convectors can be controlled by remote temperature thermostats for use in classified zones.
- **Assembly:** Valid for floors and walls (wall brackets not included. These must be ordered separately)
- **Power supply:** standard voltages ~240 V single-phase or 3~415 V three-phase.

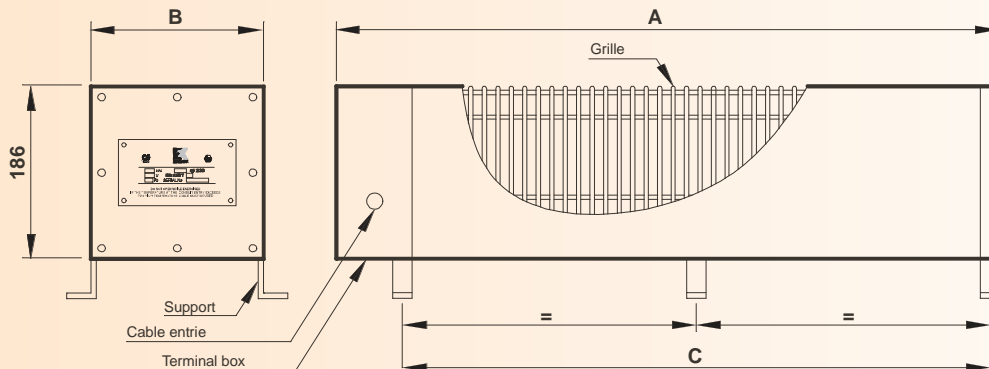
Standard FAW models
Compact range. Stainless-steel chassis
Thermal Class T3 → maximum ambient temperature: 40 °C

Code	Thermal class	Volts	Watts	Nº rods	Dimensions in mm			Weight in kg
					A	B	C	
FAW-C-250-T3	T3	~240	250	2	350	160	282	5
FAW-C-500-T3	T3	~240	500	4	350	160	282	6
FAW-C-750-T3	T3	~240	750	4	615	160	545	6
FAW-C-1000-T3	T3	~240	1000	4	615	160	545	9

Steel chassis.
Thermal Class T4 → maximum ambient temperature: 40 °C

Code	Volts	Watts	Nº rods	Dimensions in mm		
				A	B	C
FAW-250-T4	~240	250	1	1886	160	1785
FAW-500-T4	~240	500	2	1886	160	1785
FAW-750-T4	3~240 Δ 3~415 A	750	3	1886	160	1785
FAW-1000-T4	~240	1000	4	1886	272	1785
FAW-1250-T4	~240	1250	5	1886	272	1785
FAW-1500-T4	3~240 Δ 3~415 A	1500	6	1886	272	1785

Steel chassis.
Thermal Class T2 → maximum ambient temperature: 60 °C
Thermal Class T3 → maximum ambient temperature: 40 °C

Code	Volts	Watts	Nº rods	Dimensions in mm		
				A	B	C
FAW-250-Tx	~240	250	1	971	160	860
FAW-500-Tx	~240	500	2	971	160	860
FAW-750-Tx	3~240 Δ 3~415 A	750	3	971	160	860
FAW-1000-Tx	3~240 Δ 3~415 A	1000	3	1221	160	1120
FAW-1500-Tx	3~240 Δ 3~415 A	1500	3	1741	160	1640
FAW-2000-Tx	~240	2000	4	1741	272	1640
FAW-2500-Tx	~240	2500	5	1741	272	1640
FAW-3000-Tx	3~240 Δ 3~415 A	3000	6	1741	272	1640

Stainless-steel chassis.
Thermal Class T4 → maximum ambient temperature: 40 °C

Code	Volts	Watts	Nº rods	Dimensions in mm		
				A	B	C
FAW-250-S-T4	~240	250	1	1886	160	1785
FAW-500-S-T4	~240	500	2	1886	160	1785
FAW-750-S-T4	3~240 Δ 3~415 A	750	3	1886	160	1785
FAW-1000-S-T4	~240	1000	4	1886	272	1785
FAW-1500-S-T4	3~240 Δ 3~415 A	1500	6	1886	272	1785

Stainless-steel chassis.
Thermal Class T2 → maximum ambient temperature: 60 °C
Thermal Class T3 → maximum ambient temperature: 40 °C

Code	Volts	Watts	Nº rods	Dimensions in mm		
				A	B	C
FAW-250-S-T2	~240	250	1	971	160	860
FAW-500-S-T2	~240	500	2	971	160	860
FAW-750-S-Tx	3~240 Δ 3~415 A	750	3	971	160	860
FAW-1000-S-Tx	3~240 Δ 3~415 A	1000	3	1221	160	1120
FAW-1500-S-Tx	3~240 Δ 3~415 A	1500	3	1741	160	1640
FAW-2000-S-Tx	~240	2000	4	1741	272	1640
FAW-2500-S-Tx	~240	2500	5	1741	272	1640
FAW-3000-S-Tx	3~240 Δ 3~415 A	3000	6	1741	272	1640



The infrared has the property of passing through air without being absorbed and without transforming into heat until inciding with the surface of the bodies exposed to the radiation. That is why screens with infrared emissions are often the ideal solution for heating veri high premises or else providing heat to enclosed areas.

Usual applications

- Heating of interior spaces
- Areas requiring localized spot heating (workplaces, changing-rooms, etc)
- Veri high premises.
- Industrial drying up to ambient temperature of maximum 60 °C.
- Heat curtains for doors
- Generally, whenever infrared radiation is recommendable.

PANELS WITH INFRARED EMITTERS FOR HIGH LEVEL FIXED INSTALLATION, MODELS IRC

General characteristics

- Class I electrical device with minimum installation height at 1'8 m (high level installation)
- Zinc-plated steel chassis
- Polished aluminium reflector to ensure good diffusion of heating
- Chrome-plated steel protective grill to prevent accidental contact with the heating element.
- Metallic stuffing box.
- Heating element in stainless steel tube AISI 321 or 304L, thermal insulation with steel chassis.
- Additional support in zinc plated steel, ref IRS.
- End bores for ceiling attachment.
- Standard voltage ~230 V



Code	Volts	Watts	Dimensions in mm		Spectral field wavelength	Electricfor's constructive thermic class	Weight in Kg	
			A	B				
IRC1	~230	1000	545	500	1,6 to 8 μm	-	1,4	
IRC2	~230	2000	1045	1000	1,6 to 8 μm	-	2,3	
IRC3	~230	3000	1545	1500	1,6 to 8 μm	-	3,3	
IRR1	~230	1000	Heating elements spare parts			T-700-T	0,16	
IRR2	~230	2000				T-700-T	0,29	
IRR3	~230	3000				T-700-T		
IRS	Adjustable mobile support composed of 2 pieces, 1 per model							

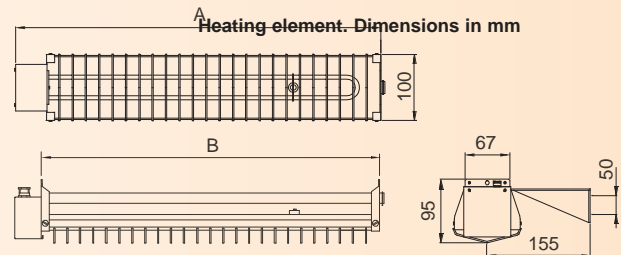
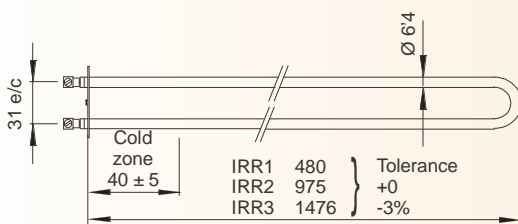

PANELS WITH INFRARED EMITTERS, MODEL IM

General characteristics

- Polished aluminium reflector to ensure good diffusion of heating
- Chrome-plated steel protective grill to prevent accidental contact with the heating element.
- Class I electrical device
- Degree protection against moisture IP44
- Connection cable H05RN 3x1'5 with 1500 mm long, with 16A connector Schuko type
- Safety thermostat with manual reset
- You can orientate the emitter with four fixed positions by means of a simple action to the side handle (see figure)
- Standard voltage ~230 V

Code	Volts	Watts	Spectral field wavelength	Weight in Kg
IM3,6	~230	3600	1,5 a 7 μm	14,6

The IM3'6 model includes the transportable trolley

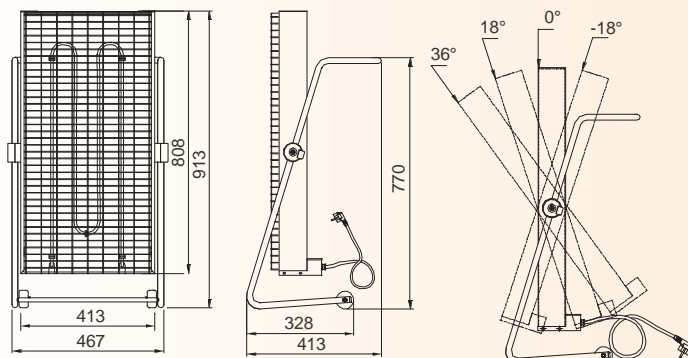
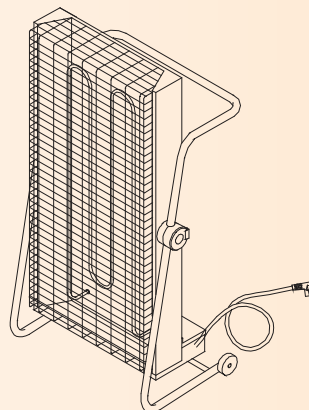

Heating element spare part

Code	Description	Volts	Watts	Weight in Kg
IMR3,6	Heating elements spare parts	~230	3600	0,68

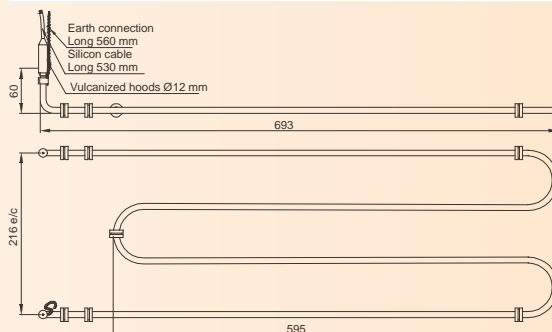

**"TH" HIGH HEATING DENSITY ELECTRIC HEATING CARTRIDGES,
MODELS IN mm.****General characteristics**

- Stainless steel tube AISI 321 rectified and calibrated, welded bottom, sealed to a pressure of 60 Kg/cm²
- Resistance of 80-20 Nickel-Chrome wire, melting point 1400 °C
- Highly compacted electromelted magnesium oxide.
- Braided nickel cables, covered with siliconized fiber glass, clamped with stainless tubular terminal on pure nickel wires that lead from the cartridge, 250 mm long, except thermocouple cables which measure 1000 mm.
- Cold zones: According to diameter, 6 to 12 mm on the connection side, and 4 to 8 mm on the welded bottom side.
- Standard voltage ~230 V.
- If you require, we can supply heating cartridges according to your specifications:
 - Diameters
 - Lengths
 - Connections: On the basis of nickel wires leading from the cartridge, other executions may be provided, such as fixed connection strips, special cables, connection elbows, flexible metal tube, sealed connections, etc.
 - All cartridges may be supplied with built-in Fe-Co themocouple.



Diameter in mm	Length in mm	Watts					With built-in Fe-Co thermocouple
6,5	40		100	125	160-175	200	100
	50		100	160	200	250	200
	60		125	200	250	315	
	80	125	180	280	350		
	100	160	220	350			350
8	40		100	160	200	250	
	50		125	200	250	315	
	60	100	140	220	280	350	
	80	160	200	315	400		
	100	180	280	400			
10	130	250	400				
	40	100	125	200	250	315	200
	50	100	160	250	315	400	250
	60	125	180	315	400	500	400
	80	160	250	400	500	630	250
	100	220	350	560	700	850	
	130	315	500	800			
12,5	160	400	630				400
	40	100	160	250	315	400	
	50	100	200	315	400	500	
	60	125	200	315	400	500	
	80	200	315	500	630	800	
	100	250	400	630	800	1000	
	130	400	630	1.000	1.250		
	160	500	800	1.250			
16	200	630	900				
	40		100	250	315	400	
	50	160	250	400	500	630	
	60	160	250	400	500	630	
	80	280	400	630	800	1000	
	100	350	500	800	1000	1250	
	130	500	700	1.100	1400	1800	
	160	630	900	1.600	1800		
	200	800	1250	2.000			
	250	1000	1600				
20	300	1250	1800				
	60	200	315	500	630	800	
	80	350	500	800	1000	1250	
	100	450	630	1.000	1400	1600	
	130	630	900	1.400	1800	2200	
	160	800	1100	1.800	2200		
	200	1000	1600	2.500			
250	1250	2000					
300	1600	2200					
Heating density		8 to 11 W/cm ²	12 to 19 W/cm ²	20 to 24 W/cm ²	25 to 29 W/cm ²	30 to 35 W/cm ²	

Tolerances

- **Diameter:** -0,02 mm
-0,08 mm
- **Length:** Up to 130 mm → ± 2 mm
From 160 mm → ± 1,5% of the total length



"TH" HIGH HEATING DENSITY ELECTRIC HEATING CARTRIDGES, MODELS IN INCHES.

General characteristics

- Stainless steel tube AISI 321 rectified and calibrated, welded bottom, sealed to a pressure of 60 Kg/cm²
- Resistance of 80-20 Nickel-Chrome wire, melting point 1400 °C
- Highly compacted electromelted magnesium oxide.
- Braided nickel cables, covered with siliconized fiber glass, clamped with stainless tubular terminal on pure nickel wires that lead from the cartridge, 250 mm long, except thermocouple cables which measure 1000 mm.
- Cold zones: According to diameter, 6 to 12 mm on the connection side, and 4 to 8 mm on the welded bottom side.
- Standard voltage ~230 V.
- If you require, we can supply heating cartridges according to your specifications:
 - Diameters
 - Lengths
 - Connections: On the basis of nickel wires leading from the cartridge, other executions may be provided, such as fixed connection strips, special cables, connection elbows, flexible metal tube, sealed connections, etc.
 - All cartridges may be supplied with built-in Fe-Co themocouple.



Diameter in inches		Length in inches	Watts					With built-in Fe-Co thermocouple
Tolerance over real diameter: +0,05mm -0 mm	1/4 " Nominal diameter: 6,35 mm Real diameter: 6,22 mm	1 1/2" (38,1)*		100	125	160-175	200	100
		2" (50,8)		100	160	200	250	200
		2 1/2" (63,5)		125	200	250	315	
		3 1/4" (82,55)	125	180	280	350		
	5/16 " Nominal diameter: 7,93 mm Real diameter: 7,87 mm	4" (101,6)	160	220	350			350
		1 1/2" (38,1)*		100	160	200	250	
		2" (50,8)		125	200	250	315	
		2 1/2" (63,5)	100	140	220	280	350	
		3 1/4" (82,55)	160	200	315	400		
	3/8 " Nominal diameter: 9,52 mm Real diameter: 9,4 mm	4" (101,6)	180	280	400			
		5 1/4" (133,35)	250	400				
		1 1/2" (38,1)*	100	125	200	250	315	200
		2" (50,8)	100	160	250	315	400	250
		2 1/2" (63,5)	125	180	315	400	500	315
		3 1/4" (82,55)	160	250	400	500	630	400
	1/2 " Nominal diameter: 12,7 mm Real diameter: 12,57 mm	4" (101,6)	220	350	560	700	850	350
		5 1/4" (133,35)	315	500	800			
		6 1/2" (165,1)	400	630				
		1 1/2" (38,1)*	100	160	250	315	400	
		2" (50,8)	100	200	315	400	500	
		2 1/2" (63,5)	125	200	315	400	500	
		3 1/4" (82,55)	200	315	500	630	800	
		4" (101,6)	250	400	630	800	1000	
	5/8 " Nominal diameter: 15,87 mm Real diameter: 15,75 mm	5 1/4" (133,35)	400	630	1.000	1.250		
		6 1/2" (165,1)	500	800	1.250			
		8" (203,2)	630	900				
		1 1/2" (38,1)*		100	250	315	400	
		2" (50,8)	160	250	400	500	630	
		2 1/2" (63,5)	160	250	400	500	630	
		3 1/4" (82,55)	280	400	630	800	1000	
		4" (101,6)	350	500	800	1000	1250	
		5 1/4" (133,35)	500	700	1.100	1.400	1800	
6 1/2" (165,1)		630	900	1.600	1800			
8" (203,2)	800	1.250	2.000					
10" (254)	1000	1600						
12" (304,8)	1250	1800						
Heating density		8 to 11 W/cm ²	12 to 19 W/cm ²	20 to 24 W/cm ²	25 to 29 W/cm ²	30 to 35 W/cm ²		

Tolerances

- **Diameter:** -0,02 mm
-0,08 mm
- **Length:** Up to 130 mm → ± 2 mm
From 160 mm → ± 1,5% of the total length



“CFOR” HIGH HEATING DENSITY ELECTRIC HEATING CARTRIDGES, MODELS IN mm.**General characteristics**

- Stainless steel tube AISI 321 ground and calibrated, welded bottom, sealed to a pressure of 60 Kg/cm²
- Resistance of 80-20 Nickel-Chrome wire, melting point 1400 °C
- Highly compacted electromelted magnesium oxide.
- Braided nickel cables, covered with siliconized fiber glass flexible from inside, 250 mm long except thermocouple cables which measure 1000 mm.
- Cold zones: According to diameter, 6 to 12 mm on the connection side, and 4 to 8 mm on the welded bottom side.
- Standard voltage ~230 V.



- If you require, we can supply heating cartridges according to your specifications:
 - Diameters
 - Lengths
 - Connections: On the basis of nickel wires leading from the cartridge, other executions may be provided, such as fixed connection strips, special cables, connection elbows, flexible metal tube, sealed connections, etc.
 - All cartridges may be supplied with built-in Fe-Co thermocouple.

Diameter in mm	Length in mm	Watts				With built-in Fe-Co thermocouple	
6,5	30				160-200-300		
	40		100	125	165	200	
	50		100-125-150	160	200	250	
	60		125-170-180	200	250	315	
	80	125-170	200-250	280-300-315	350		
	100	100-160-200	220-250-315	350-400		350	
	130	220	300-350-400				
	160	250-350	400				
	180	250-350	400				
	200	350-400	500				
8	250	250-350-400	500				
	40		100-140	160	200	250	
	50		125-160	200	250	315	
	60	100-125-140	160-200-220	250-280	315-350	350	
	80	160-180-200	250-280-315	350-400		315	
	100	180-200-250	280-315-400				
	130	250-315	400				
	160	200-315	400				
	180	250-300-400	500				
	200	300-400-500					
10	250	300-400-500					
	40	100	125-160-165	200	250	315-400	
	50	100-125	165-200	250	315	400-500	
	60	125-170	200-250	315-350	400-450	500	
	80	100-150-160-200	220-250-300-315	400-500	630	400	
	100	125-150-220-250	315-350-400	500-560	630-700	850	
	130	250-315-350	400-500-630	750-800	1000	500-1000	
	160	160-315-400-500	600-630-750-800			630	
	180	300-500	600-800				
	200	250-300-400-500	600-630-1000				
12,5	250	200-400-630	800-1000	1600			
	40	100	160-200	250	315	400	
	50	100-150-160	200-250	315	400	500	
	60	125-160-200	250-315	400	500	630	
	80	150-200-250	315-400	500-630	800	1000	
	100	250-315-400	500-630	800	1000	1250	
	130	350-400	500-630-800	1000	1250		
	160	400-500	630-800-1000	1250			
	180	500-670	800-1000	1250		670	
	200	500-630-800	900-1000	1500			
16	250	630-800-900	1000-1250-1500				
	300	600-1000	1250-1500	2000			
	40	100-160	200-250	315	400	500	
	50	160-200	250-315	400	500	630	
	60	160-200-250	315-400	500	630		
	80	250-280-315	400-500-630	800-850	1000		
	100	350-400-500	630-800	1000	1250		
	130	400-500-630	700-800	1000	1400	1800	
	160	500-630-800	900-1000-1250	1600-1800			
	180	600-850	1000-1250	1500-1800			
20	200	500-800-1000	1250	2000		2000	
	250	800-1000-1250	1600-2000				
	300	1000-1250-1500	1800-2000				
	50	200-250	315-400				
	60	200	315-400-500	630	800		
	80	315-350-400	500	800	1000-1250		
	100	400-450-500	630-800	1000-1250	1400-1600	1800	
	130	500-630	900-1000-1250	1400	1800	2200	
	160	800-1000	1250	1800	2200		
	180	1000	1250-1600	1800			
200	800-1000-1250	1600-2000	2500				
250	1000-1250-1600	2000-2500			2000		
300	1000-1250-1600	2000-2500					
Heating density		6 to 11 W/cm ²	12 to 19 W/cm ²	20 to 24 W/cm ²	25 to 29 W/cm ²	>30 W/cm ²	

Tolerances

- **Diameter:** -0,02 mm
-0,08 mm
- **Length:** Up to 130 mm → ± 2 mm
From 160 mm → ± 1,5% of the total length



EXTRA-LONG MONOTUBE HEATING ELEMENTS, MODELS CM

General characteristics

The extra-long monotube heating elements support a surface temperature of up to 600 °C maximum.

The maximum working temperature is directly related to the heating density (in this case up to 12'2 W/cm²) and the maximum ease of fit of the hole where it is lodged in the heating element. Thus, we can say that the greater the working temperature, the better the fit should be.

In the case of the monotube heating elements, for a working temperature in the mould of 400 °C it will be necessary to make a hole with minimum tolerance H11 (+0 +0'09 mm). For more information consult our catalogue nº 841, Graph 1.

General characteristics

- Stainless Steel tube with TIG welding.
- Tube laminated and calibrated WITHOUT shaving.
- Tolerance in tube Ø10 -0,02 -0,09 mm.
- Braided nickel cables, covered with siliconized fiber glass, clamped with stainless steel tubular terminal on pure nickel wires that lead from the cartridge, 250 mm long.
- Insulated with electromelted and lamination-compressed magnesium oxide.
- Ni-Cr 80/20 Resistance coil.
- Standard voltage ~230 V.
- If you require, we can supply monotube heating elements of Ø10 mm up to 1300 mm length. Also to order on other voltages..

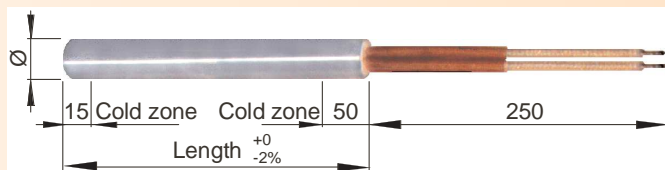

Tolerances

- Diameter: -0,02 mm
-0,09 mm
- Length: +0 %
-2%

Code	Dimensions in mm		Watts	W/cm ²	Electricfor's constructive thermic class	Weight in Kg
	Diameter	Length				
CM10x250-800	10	250	800	12	T-600-T	0,08
CM10x300-1000	10	300	1000	12	T-600-T	0,11
CM10x350-1200	10	350	1200	12	T-600-T	0,15
CM10x400-1400	10	400	1400	12	T-600-T	0,13
CM10x500-1750	10	500	1750	12	T-600-T	0,17
CM10x600-2100	10	600	2100	12	T-600-T	0,20
CM10x750-2750	10	750	2750	12	T-600-T	0,25
CM10x1000-3500	10	1000	3500	12	T-600-T	0,33

VARYBOND REGULAR GRADE® LUBRICANT

General characteristics

100 gr tins of VARYBOND REGULAR GRADE® lubricant, which simplifies the installation and removal of the cartridges while enhancing thermal conductivity. VARYBOND REGULAR GRADE® lubricant prevents formation of oxide and galvanic rust, seizures and corrosions in tools and metal parts. Applied to the metal parts, it prevents imperfections and dead periods due to repairs

VERY IMPORTANT: Do not use on cartridges with unwelded cap or when the cartridges are to be installed with the connections facing down. Do not moisten within 10 mm of the connections as this could contaminate the whole insulation.

Code: 580000000

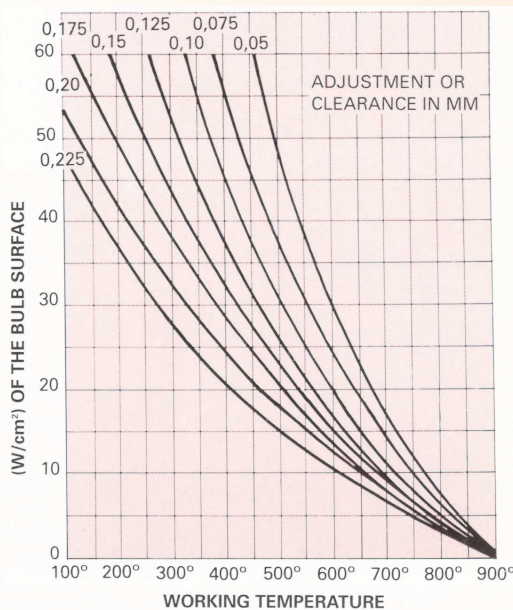

GUIDELINES FOR OBTAINING OPTIMUM PERFORMANCE IN HIGH HEATING DENSITY ELECTRIC HEATING CARTRIDGES

- Strategically select the location and number of cartridges to be installed with a view to obtaining a good distribution of heating. Take these three factors into consideration:
 1. Heat rises
 2. At equal distances, heat concentrates in the center because there is no lateral dissipation.
 3. For the same reason, the outer edges of the periphery are heated less, above all if the block to be heated is not insulated from the outside.
- Try to choose cartridges of 8 to 11 W/cm² range or, at most, of the 12 to 19 W/cm² range, and install them in scratch-free boreholes with a tolerance of H7.
- Consider using cartridges of Ø3/8" or Ø10 mm, they provide the highest performance at the lowest price.
- In event it is necessary to use cartridges of over 20 W/cm², carefully follow (applying safety margins, if possible) the assembly instructions
- To simplify the insertion-adjustment and withdrawal of the cartridge, the borehole should have an outlet. The lubricating compound NEVER-SEEZ®, which withstands a temperature of up to 1100 °C, also simplifies installation and removal in addition to improving thermal conductivity.
- Do not leave the cables inside the housing or leave the heating zone outside of the housing since the connections of the element could burn out.
- Protect the unwelded end and the connections against liquids, moisture, metallic particles, plastics, etc, which could produce leakage currents. Likewise, protect the cables against vibrations and mechanical friction.
- The temperature detection probe should be set at a maximum distance of 10 mm from the cartridge. It is recommended to use P.I.D. control temperature. Consult our catalogue pages nº 98, 99 and 100
- The minimum distance between the cartridges is equivalent to two diameters.

Example

An aluminium block should be heated to 250 °C. The required heating is of 500 W; for measurement reasons, only two cartridges of 250 W, Ø10 x 80 mm may be installed. These cartridges are within the range of 12 to 19 W/cm², so applying a density of 20 W/cm² in Graph 1 and a safety temperature of 400 °C for the part to be heated, we find that the tolerance or adjustment could be 0.25. However, the borehole is made with a precision as per ISA H7, so the adjustment calculation is as follows:

- Hole diameter: 10⁻⁰_{+0,018}, so the maximum diameter may be Ø10.018 mm.
- Cartridge diameter: 10^{-0,02}_{-0,08}, so the minimum diameter may be Ø9.92 mm.
- Maximum adjustment or clearance: 10.018 - 9.92 = 0.098 mm. We round off to 0.10 mm

According to Graph 1, between 0.25 and 0.10 there is a safety margin of 300 °C. The maximum load of W/cm² at 400 °C with an adjustment of 0.10 mm would be 45 W/cm², and since we have chosen from 12 to 19 W/cm², we are covered by over 25 W/cm².

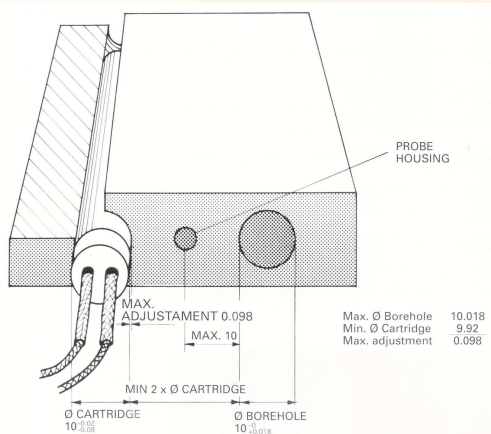

"CFOR" HIGH PERFORMANCE ANNEALED STRAIGHT TUBES FOR FORMATION OF NOZZLE CLAMPS, MODELS RC

General characteristics

RCFR heating elements are compressed ones, of high calorific density, lineal and of reduced section. These elements are available straight

- These include Fe-Co thermocouple the measuring point of which is insulated from the mass and situated about 5 mm from the end of the element.
- Maximum temperatures: 750 °C at the sheath.
200 °C at the connections.
- Connections: Nickel wires of 0.75 mm . PTFE insulation, covered with fiber glass sheath
- Thermocouple connection: Cable compensation indicated by color:(-), blue; (+), red. PTFE insulation
- Protection for connections: Cover with fiber glass sheath
- Standard voltage: ~230 V
- If you require, we can supply these elements curved in a spiral shape or other shapes according to your specifications. When requesting the bending operation, state this code and specify the inside Ø, dimension A, and the drawing number, if any.

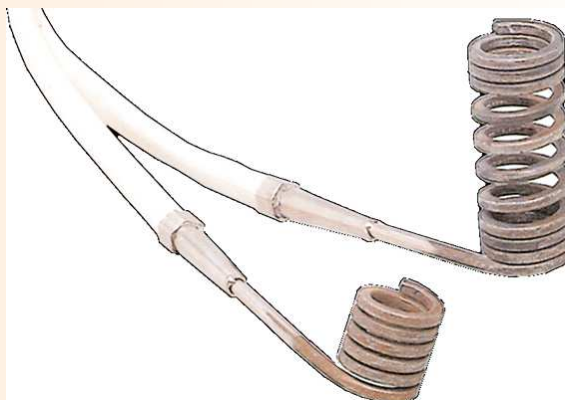

Usual applications

Their capacity of being formed cold, mechanically or manually, allows heating of highly diverse pieces, being especially used in heating of injection nozzles in the plastic industry.

Other applications: mechanical industry, packaging industry (sealing, soldering). Railways (protection against freezing in carriage couplings).

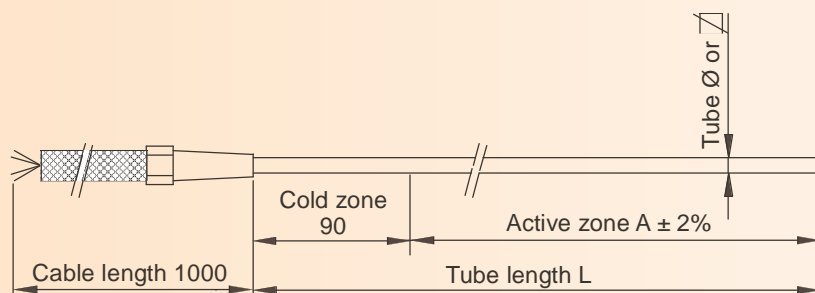

MODELS RCFR

○ Ø3 mm

MODELS RCFRC

□ 3 x 3 mm

MODELS RCFRR

□ 2,2 x 4,2 mm

SQUARE TUBE 3x3 mm, MODELS RCFRC

Code	Dimensions in mm		Watts	Weight in Kg
	Length L	Active zone A		
RCFRC175110	200	110	175	0,03
RCFRC175150	240	150	175	0,04
RCFRC225210	300	210	225	0,05
RCFRC250260	350	260	250	0,05
RCFRC215300	390	300	215	0,06
RCFRC300310	400	310	300	0,06
RCFRC350360	450	360	350	0,07
RCFRC400410	500	410	400	0,08
RCFRC325460	540	460	325	0,08
RCFRC500510	600	510	500	0,09
RCFRC400560	650	560	400	0,10
RCFRC500610	700	610	500	0,11
RCFRC470650	740	650	470	0,11
RCFRC600710	800	710	600	0,12
RCFRC700810	900	810	700	0,14
RCFRC610850	940	850	610	0,14
RCFRC800910	1000	910	800	0,15
RCFRC6301050	1140	1050	630	0,17
RCFRC9001110	1200	1110	900	0,18
RCFRC7501410	1500	1410	750	0,23
RCFRC11001710	1800	1710	1100	0,27
RCFRC14001910	2000	1910	1400	0,30

ROUND TUBE Ø3 mm, MODELS RCFR

Code	Dimensions in mm		Watts	Weight in Kg
	Length L	Active zone A		
RCFR180310	400	310	180	0,06
RCFR250460	550	460	250	0,07
RCFR315560	650	560	315	0,07
RCFR400710	800	710	400	0,08
RCFR500860	950	860	500	0,08
RCFR6301060	1150	1060	630	0,09

RECTANGULAR TUBE 2,2x4,2 mm, MODELS RCFRR

Code	Dimensions in mm		Watts	Weight in Kg
	Length L	Active zone A		
RCFRR175110	200	110	175	0,09
RCFRR190160	250	160	190	0,10
RCFRR200240	330	240	200	0,10
RCFRR225290	380	290	225	0,11
RCFRR250340	430	340	250	0,11
RCFRR300390	480	390	300	0,12
RCFRR350470	560	470	350	0,12
RCFRR400540	630	540	400	0,13
RCFRR450610	700	610	450	0,13
RCFRR550660	750	660	550	0,13
RCFRR625770	860	770	625	0,14
RCFRR675860	950	860	675	0,14
RCFRR700910	1000	910	700	0,14
RCFRR8001110	1200	1110	800	0,15
RCFRR9501310	1400	1310	950	0,15
RCFRR11001510	1600	1510	1100	0,15
RCFRR12001710	1800	1710	1200	0,16
RCFRR13001910	2000	1910	1300	0,16
RCFRR14002160	2250	2160	1400	0,16



“TH” HIGH PERFORMANCE ANNEALED STRAIGHT TUBES FOR FORMATION OF NOZZLE CLAMPS, MODELS ATB



General characteristics

ATBR heating elements are compressed ones, of high calorific density, lineal and of reduced section. These elements are available straight

- These include Fe-Co thermocouple the measuring point of which is insulated from the mass and situated about 5 mm from the end of the element.
- Maximum temperatures: 750 °C at the sheath.
200 °C at the connections.
- Connections: Nickel wires of 0.75 mm . PTFE insulation, covered with fiber glass sheath
- Thermocouple connection: Cable compensation indicated by color:(-), blue; (+), red. PTFE insulation
- Protection for connections:
MODELS ATBR / ATBRC → Covered with metallic mesh
MODELS ATBRR → Covered with fiber glass sheath
- Standard voltage: ~230 V
- If you require, we can supply these elements curved in a spiral shape or other shapes according to your specifications. When requesting the bending operation, state this code and specify the inside Ø, dimension A, and the drawing number, if any.

Usual applications

Their capacity of being formed cold, mechanically or manually, allows heating of highly diverse pieces, being especially used in heating of injection nozzles in the plastic industry.

Other applications: mechanical industry, packaging industry (sealing, soldering). Railways (protection against freezing in carriage couplings).

ANNEALED STRAIGHT TUBES FOR FORMATION OF NOZZLE CLAMPS, MODELS ATBR , ATBRC and ATBRR

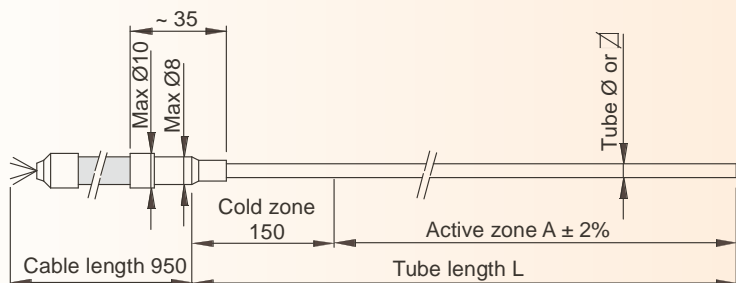

MODELS ATBR

○ Ø4 mm

MODELS ATBRC

□ 3 x 3 mm

MODELS ATBRR

□ 2,2 x 4,3 mm

ROUND TUBE Ø4 mm, MODELS ATBR

Code	Dimensions in mm		Watts	Weight in Kg
	Length L	Active zone A		
ATBR200250	400	250	200	0,08
ATBR315400	550	400	315	0,09
ATBR400600	750	600	400	0,09
ATBR500800	950	800	500	0,10
ATBR6301000	1150	1000	630	0,10
ATBR7501200	1350	1200	750	0,10
ATBR10001500	1650	1500	1000	0,11

SQUARE TUBE 3x3 mm, MODELS ATBRC

Code	Dimensions in mm		Watts	Weight in Kg
	Length L	Active zone A		
ATBRC180300	400	300	180	0,10
ATBRC250450	550	450	250	0,11
ATBRC400700	800	700	400	0,12

RECTANGULAR TUBE 2,2x4,3 mm, MODELS ATBRR

Code	Dimensions in mm		Watts	Weight in Kg
	Length L	Active zone A		
ATBRR400700	800	700	400	0,12
ATBRR6301000	1100	1000	630	0,12
ATBRR7501200	1300	1200	750	0,13

HIGH PERFORMANCE NOZZLE LOOP CLAMPS, MODELS ATB

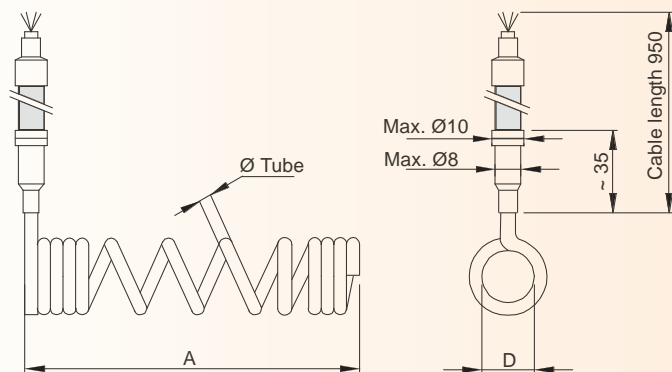

MODELS ATB

○ Ø4 mm

Code	Dimensions in mm			Watts	Weight in Kg
	A	D	Ø Tubo		
ATB12,5x70	70	12,5	4	315	0,10
ATB12,5x103	103	12,5	4	400	0,12
ATB12,5x110	110	12,5	4	400	0,13
ATB12,5x130	130	12,5	4	400	0,13
ATB12,8x150	150	12,8	4	400	0,13
ATB22x110	110	22	4	500	0,15
ATB22x160	160	22	4	1000	0,18

ANNEALED STRAIGHT SQUARE TUBES, MODELS TC

Straight annealed square tube elements are the ideal solution for those applications in which uniform distribution of heat over the mould to be heated is required. The high degree of flexibility achieved thanks to the thermic treatment to which the stainless steel tube is subjected in a controlled atmosphere oven at temperatures of 1150°C, allows the element to be curved directly over the metal mould, achieving the shape that is required.

General characteristics

- Shielded tubular elements in annealed AISI321 stainless steel of 6.1x6.1 mm or 7.6x7.6 mm square section.
- Resistive wire of Ni-Cr alloy quality 80-20
- Heating element insulated with electro-smelted magnesium-oxide and compressed by lamination.
- High thermic performance due to the flat contacts sides.
- Plain terminal of Ø2.5 mm for section 6.1x6.1 mm models or Ø3 mm for section 7.6x7.6 mm models
- Standard voltage: ~230 V
- To order, heating elements can be made to measure according to your specifications:
 - Other dimensions, powers and voltages
 - Possibility of manufacturing in square section of 9.4x9.4 mm up to lengths of 3600 mm.

Usual applications

- Heating by external contact of tanks.
- Maintenance of solids in liquid state: fats, wax, honey, etc.
- Drying of solids: rubber, grain, sand, etc.
- Machinery for the conversion of plastics, bakelites, epoxies, polyesters and rubber.
- Hot chambers
- Hot moulds
- Heating of metallic masses
- Footwear machinery
- Packaging machinery
- Marking machinery



6'1x6'1 mm SQUARE TUBE, MODELS TC6,1

Code	Dimensions in mm			Watts	W/cm ²	Electricfor's constructive thermic class	Weight in Kg
	L	ZA	ZI				
TC6,1X350-550	350	290	30	550	7,9	T-750-T	0,05
TC6,1X400-650	400	340	30	650	8	T-750-T	0,06
TC6,1X450-750	450	390	30	750	8	T-750-T	0,07
TC6,1X500-800	500	440	30	800	7,6	T-750-T	0,08
TC6,1X550-900	550	490	30	900	7,6	T-750-T	0,09
TC6,1X600-1000	600	540	30	1000	7,7	T-750-T	0,10
TC6,1X650-1100	650	590	30	1100	7,7	T-750-T	0,11
TC6,1X700-1200	700	640	30	1200	7,8	T-750-T	0,12
TC6,1X750-1300	750	690	30	1300	7,8	T-750-T	0,13
TC6,1X800-1350	800	740	30	1350	7,5	T-750-T	0,14
TC6,1X850-1450	850	790	30	1450	7,6	T-750-T	0,15
TC6,1X900-1650	900	840	30	1650	8,1	T-750-T	0,16
TC6,1X900-2000	900	840	30	2000	9,8	T-750-T	0,16
TC6,1X950-1650	950	890	30	1650	7,6	T-750-T	0,17
TC6,1X1000-1750	1000	940	30	1750	7,7	T-750-T	0,18
TC6,1X1050-1850	1050	990	30	1850	7,7	T-750-T	0,19
TC6,1X1100-1950	1100	1040	30	1950	7,7	T-750-T	0,20
TC6,1X1150-2050	1150	1090	30	2050	7,7	T-750-T	0,21
TC6,1X1200-2100	1200	1140	30	2100	7,6	T-750-T	0,22
TC6,1X1250-2200	1250	1190	30	2200	7,6	T-750-T	0,23
TC6,1X1300-2300	1300	1240	30	2300	7,6	T-750-T	0,24
TC6,1X1350-2400	1350	1290	30	2400	7,7	T-750-T	0,25
TC6,1X1400-2500	1400	1340	30	2500	7,7	T-750-T	0,26
TC6,1X1450-2600	1450	1390	30	2600	7,7	T-750-T	0,27
TC6,1X1500-2700	1500	1440	30	2700	7,7	T-750-T	0,28
TC6,1X1550-2800	1550	1490	30	2800	7,7	T-750-T	0,29

7'6x7'6 mm SQUARE TUBE, MODELS TC7,6

Code	Dimensions in mm			Watts	W/cm ²	Electricfor's constructive thermic class	Weight in Kg
	L	ZA	ZI				
TC7,6X400-950	400	340	30	950	9,2	T-750-C	0,10
TC7,6X450-1050	450	390	30	1050	8,9	T-750-C	0,11
TC7,6X500-1200	500	440	30	1200	9	T-750-C	0,12
TC7,6X550-1350	550	490	30	1350	9,1	T-750-C	0,14
TC7,6X600-1450	600	540	30	1450	8,9	T-750-C	0,15
TC7,6X650-1600	650	590	30	1600	8,9	T-750-C	0,16
TC7,6X700-1750	700	640	30	1750	9	T-750-C	0,17
TC7,6X750-1900	750	690	30	1900	9,1	T-750-C	0,19
TC7,6X800-2000	800	740	30	2000	8,9	T-750-C	0,20
TC7,6X850-2150	850	790	30	2150	9	T-750-C	0,21
TC7,6X900-2300	900	840	30	2300	9	T-750-C	0,22
TC7,6X950-2450	950	890	30	2450	9,1	T-750-C	0,24
TC7,6X1000-2550	1000	940	30	2550	8,9	T-750-C	0,25
TC7,6X1050-2700	1050	990	30	2700	9	T-750-C	0,26
TC7,6X1100-2850	1100	1040	30	2850	9	T-750-C	0,27
TC7,6X1200-3100	1200	1140	30	3100	9	T-750-C	0,30
TC7,6X1300-3400	1300	1240	30	3400	9	T-750-C	0,32
TC7,6X1400-3650	1400	1340	30	3650	9	T-750-C	0,35
TC7,6X1500-3900	1500	1440	30	3900	8,9	T-750-C	0,37
TC7,6X1600-4200	1600	1540	30	4200	9	T-750-C	0,40
TC7,6X1700-4500	1700	1640	30	4500	9	T-750-C	0,42
TC7,6X1800-4800	1800	1740	30	4800	9,1	T-750-C	0,45
TC7,6X1900-5000	1900	1840	30	5000	8,9	T-750-C	0,47
TC7,6X2000-5300	2000	1940	30	5300	9	T-750-C	0,50

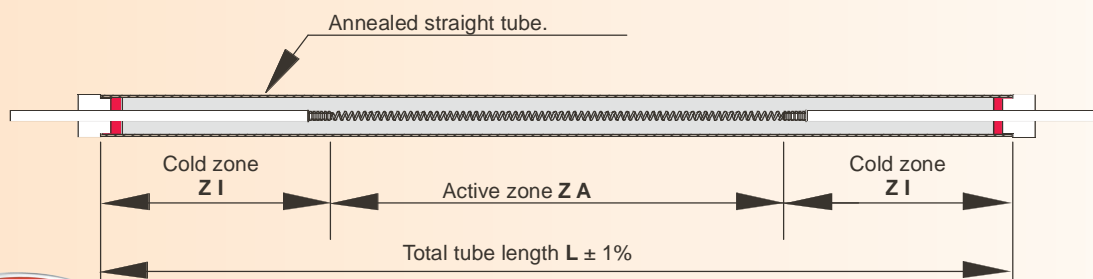

GROUP 9 - Clamp type elements

9.4 - Clamp heating elements

Models as per catalogue: NTC-1080 / 1180

General characteristics

- Steel-zinc or stainless steel sheath
- Heating element of Nickel-Chrome quality 80-20 alloyed wire or ribbon, wound around mica insulator adaptable to high temperatures (up to 500°C depending on constructions)
- Possibility of making entries for thermocouple, links or holes as per the client's needs
- Normal execution with screw closure or bolt flange with Allen screw.
- Different types of electric connection: Screws - Plugged in - Flexible leads - Ceramic connector.
- Optional executions:
 - Articulated with hinge.
 - Double thermic insulation.
 - Air chamber.
 - With ceramic or mica support or shielded heating elements.
- Sizes, watts and volts as per technical characteristics and requirements



GROUP 9 - Clamp type elements

9.5 - Flat heating elements

Models as per catalogue: NTC-1080 / 1180

General characteristics

- Steel-zinc or stainless steel sheath
- Heating element of Nickel-Chrome quality 80-20 alloyed wire or ribbon, wound around mica insulator adaptable to high temperatures (up to 500°C depending on constructions)
- Possibility of making entries for thermocouple, links or holes as per the client's needs
- Normal execution with screw closure or bolt flange with Allen screw.
- Different types of electric connection: Screws - Plugged in - Flexible leads - Ceramic connector.



GROUP 9 - Clamp type elements

9.6 - Connectors

Models as per catalogue: NTC-1080 / 1180

STRAIGHT ALUMINIUM CONNECTOR - 25 A

- Quick connector plug in aluminium and silicone base.
- Maximum admissible current: 25 A
- Code: 576004000

ELBOWED ALUMINIUM CONNECTOR - 25 A

- Fast connection plug with aluminium body at right angles and silicone base, for use in places in which space does not permit using a straight plug
- Maximum admissible current: 25 A
- Code: 576005000



HERMETIC CLAMPS FOR NOZZLES, MODELS RCAH

General characteristics

- Sheath in brass or stainless steel.
- Heating element in wire or ribbon Nickel-Chrome alloy 80-20 quality, wound around mica insulation adaptable to high temperatures.
- Connection cables with mesh protection (2 wires + ground wire) of 400 mm long.
- Standard voltage ~230 V.
- If you require, we can supply with other dimensions, voltages and power. Also, with holes for thermocouple.

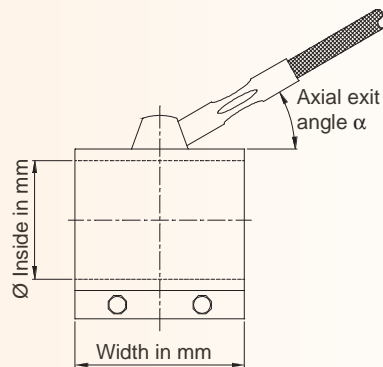

HERMETIC CLAMPS FOR NOZZLES IN BRASS SHEATH, MODELS RCAH45

Code	Dimensions in mm		Watts	Weight in Kg
	Øinside	Wide		
RCAH45-25X30	Ø25	30	120	0,11
RCAH45-30X20	Ø30	20	95	0,10
RCAH45-30X25	Ø30	25	120	0,10
RCAH45-30X30	Ø30	30	140	0,12
RCAH45-30X40	Ø30	40	190	0,12
RCAH45-35X20	Ø35	20	110	0,11
RCAH45-35X25	Ø35	25	135	0,10
RCAH45-35X30	Ø35	30	165	0,11
RCAH45-35X35	Ø35	35	190	0,12
RCAH45-35X40	Ø35	40	220	0,13
RCAH45-35X45	Ø35	45	250	0,13
RCAH45-40X20	Ø40	20	125	0,10
RCAH45-40X25	Ø40	25	155	0,11
RCAH45-40X30	Ø40	30	190	0,12
RCAH45-40X35	Ø40	35	220	0,13
RCAH45-40X40	Ø40	40	250	0,14
RCAH45-40X50	Ø40	50	315	0,15
RCAH45-43X40	Ø43	40	225	0,11
RCAH45-43X50	Ø43	50	300	0,12
RCAH45-43X60	Ø43	60	375	0,13
RCAH45-45X25	Ø45	25	175	0,11
RCAH45-45X30	Ø45	30	210	0,12
RCAH45-45X40	Ø45	40	280	0,13
RCAH45-50X20	Ø50	20	195	0,12
RCAH45-50X30	Ø50	30	235	0,13
RCAH45-50X40	Ø50	40	315	0,14
RCAH45-50X50	Ø50	50	390	0,15
RCAH45-55X30	Ø55	30	260	0,14
RCAH45-60X30	Ø60	30	280	0,15
RCAH45-80X40	Ø80	40	500	0,18
RCAH45-25X30	Ø25	30	120	0,11

HERMETIC CLAMPS FOR NOZZLES IN STAINLESS STEEL SHEATH, MODELS RCAH30-I

Code	Dimensions in mm		Watts	Weight in kg
	Øinside	Wide		
RCAH30-24X34-I	Ø24	34	125	0,12
RCAH30-30X25-I	Ø30	25	140	0,11
RCAH30-30X30-I	Ø30	30	150	0,11
RCAH30-32X30-I	Ø32	30	150	0,13
RCAH30-32X38-I	Ø32	38	225	0,13
RCAH30-35X25-I	Ø35	25	160	0,12
RCAH30-35X30-I	Ø35	30	180	0,11
RCAH30-35X38-I	Ø35	38	250	0,12
RCAH30-35X48-I	Ø35	48	310	0,13
RCAH30-40X30-I	Ø40	30	250	0,14
RCAH30-40X38-I	Ø40	38	300	0,14
RCAH30-40X42-I	Ø40	42	325	0,11
RCAH30-45X30-I	Ø45	30	250	0,12
RCAH30-45X48-I	Ø45	48	400	0,13
RCAH30-50X30-I	Ø50	30	275	0,14
RCAH30-50X55-I	Ø50	55	490	0,15
RCAH30-55X25-I	Ø55	25	230	0,16
RCAH30-55X38-I	Ø55	38	400	0,12
RCAH30-55X48-I	Ø55	48	500	0,13
RCAH30-60X20-I	Ø60	20	210	0,14
RCAH30-60X38-I	Ø60	38	450	0,12
RCAH30-65X25-I	Ø65	25	290	0,13
RCAH30-65X42-I	Ø65	42	500	0,14
RCAH30-70X30-I	Ø70	30	400	0,13
RCAH30-70X38-I	Ø70	38	500	0,14
RCAH30-70X48-I	Ø70	48	650	0,15
RCAH30-80X30-I	Ø80	30	450	0,16
RCAH30-80X48-I	Ø80	48	750	0,15
RCAH30-90X30-I	Ø90	30	500	0,21
RCAH30-90X42-I	Ø90	42	800	0,16
RCAH30-100X30-I	Ø100	30	600	0,19

Connection cables with mesh protection (2 wires + ground wire) of 400 mm long.

Axial exit: Angle $\alpha = 45^\circ$



Maximum working temperature: 375 °C

Connection cables with mesh protection (2 wires + ground wire) of 400 mm long.

Axial exit: Angle $\alpha = 30^\circ$



Maximum working temperature: 450 °C



GROUP 9 - Clamp type elements

9.8 - Monotube heating elements of two circuits with triangular profile

L-ETM

MONOTUBE HEATING ELEMENT OF 2 CIRCUITS WITH TRIANGULAR PROFILE, MODELS L-ETM

General characteristics

- Stainless steel tube compressed to form the triangular profile.
- Heating wire in Nickel-Chrome alloy, with two circuits and one common terminal to make different powers according to connection.
- Insulated with electromelted compressed magnesium oxide.
- Standard voltage ~230 V.

These heating elements can be driven through a energy regulator or by means with a switch of several positions, with a maximum of five. With this last device and carrying out the feeding of the heating element according to the attached tables, the range of powers obtained will be as shown in the table.

Code	Heating power	0	1	2	3	4
511000001	500 W	0 W	125 W	250 W	250 W	500 W
511002001	1000 W	0 W	250 W	500 W	500 W	1000 W
511003001	1250 W	0 W	310 W	550 W	700 W	1250 W

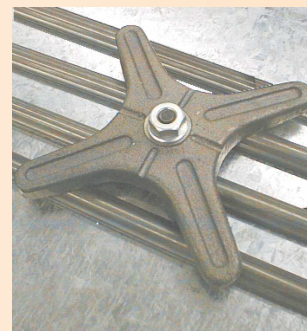

Example of installation with 4 L-ETM heating element with cross bridle

Code	Reference	Dimensions in mm			Watts	Weight in Kg
		L	A	(*) B		
511000001	L-ETM-345	345	53	26	500	0,16
511002001	L-ETM-605	605	53	26	1000	0,28
511003001	L-ETM-705	705	53	26	1250	0,33

(*) Terminal connector included

ACCESSORIES FOR MONOTUBE L-ETM

511009001	Set formed by bridle in cross, nut, washer and weldable flange
-----------	--

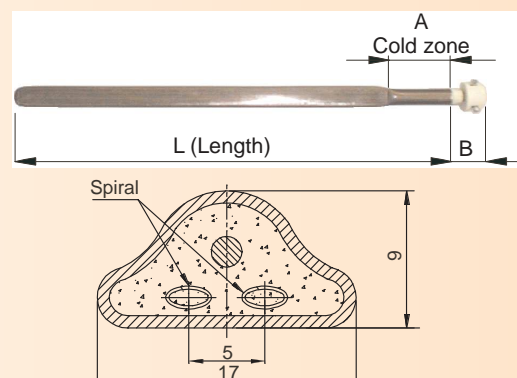

GROUP 9 - Clamp type elements

9.9 - Triangular "Clamp" heating elements

L-ENC-FE

Models as per catalogue: NTC-0202



TRIANGULAR "CLAMP" HEATING ELEMENTS, MODELS L-ENC-FE

Usual applications

- Heating of tanks by external contact.
- Mould heating.

- Lead and tin baths.
- Drying of solids.
- Hot tables.

General characteristics

- Tubular element in stainless steel tube AISI 321 or AISI 304L of Ø8'5 mm, embedded in a cast steel mould and subsequently pressed.
- Cast steel mould of 20 mm thick.
- Standard voltage ~230 V.

Although these are the maximum working temperatures, one must take into account consider that the seal of the heating element withstands a maximum end temperature of up to 250 °C

Maximum working temperature		
511006001	1200 W	350 °C
511008001	1800 W	200 °C

Code	Reference	Watts	Weight in Kg	Electricfor's constructive thermic class
511006001	L-ENC-FE-1,2	1200	3,5	T-700-T
511008001	L-ENC-FE-1,8	1800	3,5	T-700-T

Typical compositions with flat "Clamp" heating elements

Set in circle of 3 flat "clamps"

Set in circle of 6 flat "clamps"

Set in circle of 9 external flat "clamps" or 8 external and 1 on the inside

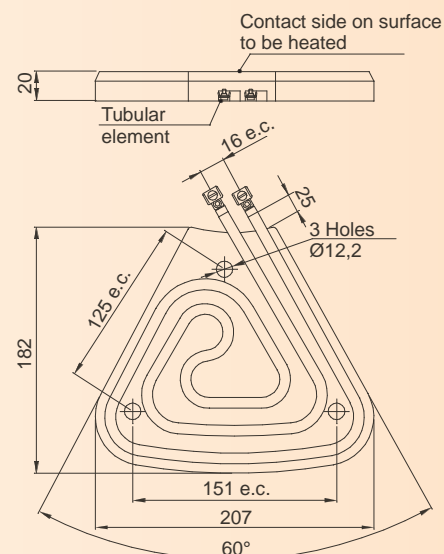
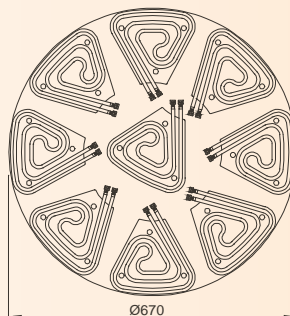
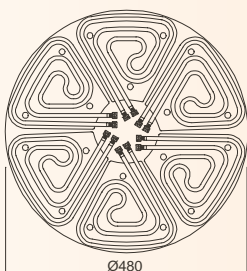
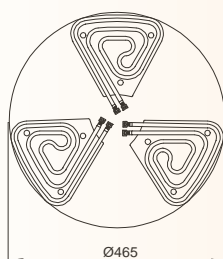

GROUP 10 - Small electric home appliance elements

10.1 - Shielded kitchen plates

General characteristics

Basically, the shielded kitchen plates consist of a cast iron plate, inside which are housed three electric heating elements embedded in a material providing electrical insulation, but which is a good conductor of heat. These insulated elements are sealed inside and protected by a sheathed cover, a connection block ensuring good connections. The stainless steel ring around the plate is not merely ornamental, but also enables the plate to be correctly fitted into the top of the cooker. The heating surface of the hotplate is rust-proofed with heat-resistant lacquer.

Models with thermal protector, reduce the power if heat produced is not used. This does not come into action if the hotplate is being used normally.



Code	Description	Volts	Watts	Weight in kg
599009000	Shielded kitchen plate Ø80mm	~230	450	0,70
599000000	Shielded kitchen plate Ø145mm	~230	1000	1,1
599001000	Shielded kitchen plate Ø145mm. With overload and bimetallic protector.	~230	1500	1,1
599004000	Shielded kitchen plate Ø180 mm.	~230	1500	1,7
599003000	Shielded kitchen plate Ø180 mm. With overload and bimetallic protector.	~230	2000	1,7

POSITIONS AND WIRING DIAGRAMS

By selecting a type of control appropriate to requirements, any of a wide range of power outputs may be obtained.

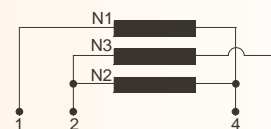

Power	Partial power			Power steps for 4 positions				Power	Partial power			Power steps for 7 positions						
	N1	N2	N3	3	2	1	0		N1	N2	N3	6	5	4	3	2	1	0
450 W	225 W	225 W	---	450 W	225 W	225 W	0 W	1000 W	500 W	250 W	250 W	1000 W	500 W	250 W	250 W	125 W	107 W	0 W
1000 W	500 W	250 W	250 W	1000 W	500 W	250 W	0 W	1500 W	750 W	250 W	500 W	1500 W	750 W	500 W	250 W	165 W	135 W	0 W
1500 W	750 W	250 W	500 W	1500 W	750 W	375 W	0 W	2000 W	850 W	300 W	850 W	2000 W	1150 W	850 W	300 W	220 W	175 W	0 W
2000 W	850 W	300 W	850 W	2000 W	1150 W	490 W	0 W											

ACCESSORIES FOR SHIELDED KITCHEN PLATES

Code	Reference	Description
599098999	X-COM-7P-F	7 Positions switch. Without lamp. 16 A - 250 V.
517230000	ENERGY REGULATOR	Energy regulator . 200 / 240 V. 13 A
517230001	(By means of percentage variations of ON / OFF periods of load circuit)	White button for energy regulator / timer.

BF / BZ

Models as per catalogue: NTC-9010 / 9090

General characteristics

Heating elements for heaters or industrial use

- Resistive coil in Ni-Cr alloy
- Ceramic tube for support the resistive coil
- Standard voltage: ~230 V

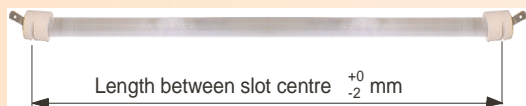

General characteristics

- Resistive coil in Nickel-Chrome alloy
- Quartz tube of Ø10 mm
- Ceramic supports resistant to temperature
- Faston terminals 6'3 mm
- Standard voltage: ~230 V
- If you require, also available for supply with fiber glass tail connection outlets.
- Other power, voltage and models are available on demand

GROUP 10 - Small electric home appliance elements

10.2 - Heater bars with or without support

Code	Watts	Length in mm	Adaptable
BF005	600	290	SO
BF009	500	230	FU

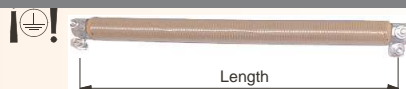

Code	Watts	Length between slot centre in mm	Adaptable	Weight in Kg
BZ001	600	354	UF	0,07
BZ002	600	370	KE	0,07
BZ003	600	390	KE	0,08
BZ004	600	400	UF	0,08
BZ005	750	455	SO	0,09
BZ006	750	516	UF	0,10
BZ007	750	600	UF	0,13

PA

Models as per catalogue: NTC-9010 / 9090

GROUP 10 - Small electric home appliance elements

10.3 - Markers, burners and lighters

MARKERS, BURNERS AND LIGHTERS, MODELS PA



General characteristics

- Tubular elements in stainless steel AISI 321 or Incoloy®-800 tube
- Anatomical handle, with degree protection against moisture IP-20
- Hose cable type H07RN-F of 3 x 0'75 mm², 1500 mm long.
- Connection jack type Schuko of 16 A, with built-in earth connection.
- Standard voltage: ~230 V

Description	Code	L in mm	Watts	Tube material	Weight in Kg	Electricfor's constructive thermic class
Round burner of Ø85 mm heating zone.	(1) PA-2	245	350	AISI 321 Ø6,4 mm	0,31	T-700-T
Marker, lighter of Ø115 mm heating zone.	(1) PA-4	295	500	AISI 321 Ø8 mm	0,39	T-700-T
Marker, "U-shape" lighter	(1) PA-3	295	600	Incoloy 800 Ø8 mm	0,37	T-850-T
Marker, long lasting rectangular lighter	(2) PA-5	345	600	Incoloy 800 Ø8 mm	0,42	T-850-T

NOTES:





(1) Models in stock. (2) Model available on demand.

C./ Ca n'Alzamora, 34 - 36
Tel. +34 697 78 10
www.electricfor.com

08191 - Rubí - Barcelona - Spain
Fax +34 93 586 00 48
electricfor@electricfor.com

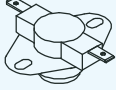
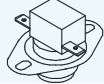
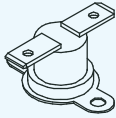

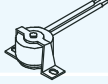
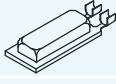
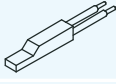
In keeping with our policy of always offering the most advanced products available, we represent Sensata thermostats in Spain. Sensata, creator of the popular KLIXON, is the leading firm in this field worldwide. This is shown by its many plants around the world and the obtainment of Company Certification as per standard ISO 9001, which verifies the implementation of an efficient quality system.

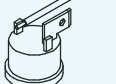
Type	Admissible current at 250 V. (Cycles)	Influence on current when tripped	Contact	Reset	Fastons	Temperatures of action on heat, in °C. In stock (1)	Temp. amb, max °C	Trip tolerance in °C	Family Ref-Code	
	LARGE KLIXON 206	25 A. (100.000)	NULL	NC	AUTOM.	Flat	92	175	± 5	511
						90°	41	175	± 5	512
				NO	AUTOM.	Flat	ON REQUEST	175	± 5	514
				NC	MANUAL	Flat	ON REQUEST	175	± 5	515
	LARGE KLIXON 2TT	15 A. (30.000)	NULL	NC	AUTOM.	Flat	60-ARS; 70-S; 125-S	130	± 5	521
						45°	75-AR; 92-AR	130	± 5	522
	SMALL KLIXON PK1	16 A. (10.000)	NULL	NC	AUTOM.	Flat	84(20); 120(11); 125-A(15); 145-AP(12)	130	± 5	531
						90°	85-AP; 121-AP	210	± 5	532
		NO		AUTOM.	Flat	45(10); 50-A(15); 80-A(11); 140-A(14)	210	± 5	533	
		NC		MANUAL	Flat	120-AES	210	± 3	535	
	SMALL KLIXON 1NT	16 A. (30.000)	NULL	NC	AUTOM.	Flat	60(10); 75(11); 85(11); 110(11); 120(11); 150(14)	210	± 5	541
						90°	28-S(11); 110-S(10); 180(14)	210	±3,5	542
		NO		AUTOM.	Flat	120(11)	210	±3,5	543	
					90°	44(11)	210	±4	544	
		10 A. (100.000)	NULL	NC	MANUAL	Flat	85; 120	210	±3,5	545
					90°	125	210	±5	546	
For thermostats WITHOUT fixation flange		Fixation flange for thermostats PK1 and 1NT.						570004310		
		Fixation flange for thermostats 1NT02.					Code:	570004320		
		Fixation double flange for thermostats 1NT02.						570004325		
	CERAMIC	25 A.	NULL	NO	AUTOM.	Flat	80(28)			513
	SEALED 20640	5 A. (100.000)	NULL	NC	AUTOM.		22-C(21)	-53 to 75	± 5	512
	20420	25 A. (100.000)	NULL	NC	AUTOM.		21-T(11)			
	15AM	18 A. (10.000)	LOW	NC	AUTOM.		100 (20)	180	± 5	551
			MEDIUM	NC	AUTOM.		ON REQUEST	180	± 5	554
			HIGH	NC	AUTOM.		ON REQUEST	180	± 5	556
	9700	13 A. (10.000)	LOW	NC	AUTOM.		65-K; 75; 90; 120; 135; 140; 150	175	± 7	561
			MEDIUM	NC	AUTOM.		ON REQUEST	175	± 7	563
			HIGH	NC	AUTOM.		75	175	± 7	565
	2MM	3 A. (5.000)	LOW	NC	AUTOM.		70; 130; 150	175	± 10	571
			HIGH	NO	AUTOM.		ON REQUEST	175	± 10	573
	TH10	13 A. (10.000)	LOW	NC	AUTOM.		85-AV; 100-AU	200	± 5	581
			HIGH	NC	AUTOM.		ON REQUEST	200	± 5	582
	MRP	37 A.	LOW	NC	AUTOM.		ON REQUEST	175		587
				NC	MANUAL		ON REQUEST	175		589
			MEDIUM	NC	AUTOM.		120	175		591
				NC	MANUAL		ON REQUEST	175		593
			HIGH	NC	AUTOM.		ON REQUEST	175		595
				NC	MANUAL		ON REQUEST	175		597

NC= Normally closed. When the temperature rises it opens to disconnect → disconnect

NO= Normally open. When the temperature rises it closes to connect → connect

(1) THE LETTERS FOLLOWING EACH TEMPERATURE HAVE THE FOLLOWING MEANING:

NO LETTER - As in the drawing

A - Several differences, enquire

B - With thimble as in drawing of 206 and 2TT

C - With clip for attachment to 1/2" and 3/8" tubing.

D - Diagonal attachment

E - Fastons of 4.8 mm

F - Fixed flange

K - Several differences, enquire (Cod: 1762230000)

H - With cable

P - Central bolt attachment

R - Fast-on with 90° bend

S - No attachment flange

T - Several differences, enquire

U - Abrupt rupture

V - Slow rupture

Y - Distinct cables

Z - Several differences, enquire

NOTE: PLEASE CONSULT DIFFERENTIAL FOR EACH TYPE AND TEMPERATURE

() - Parentheses indicate the thermostat differential (Difference of degrees between disconnection and connection or vice versa).

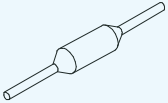
Type	Admissible current at 250 V	Influence on current when tripped	Contact	Reset	Temperature of action on heat, In °C. In stock (1)	Trip tolerance °C	Family Ref - Code
 FUSE	10 A	LOW	NC	NEVER	104; 167; 192; 229; 240	± 5	511
	15 A				60; 93; 98; 117; 121; 128; 152; 184; 216	± 5	512

BULB THERMOSTATS

GROUP 11 - Control and regulation

11.1 - Bulb and capillary thermostats

Single-pole bulb and capillary thermostats

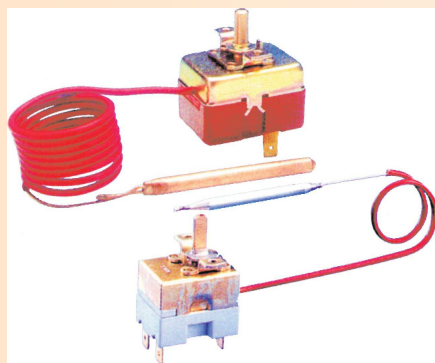

Bulb and capillary thermostats to include in the Europa Range

Single-pole snap action thermostats. 3 to 5 °C differential depending on temperate scales. Bulb and capillaries in copper up to 160°C, and in stainless steel for over 160°C. Connection to 6.3 mm fastons.

The thermostat units for each of the temperatures comprise the standard thermostat with its respective buttons, cover and connection screws.

Code	Thermostat range	Range	Characteristics	Max current (~240 V)	Weight in Kg
3509310324	CA	0 / 40 °C	Bulb in copper Ø6,5x142 mm Capillary 1m. 3 Faston	16 A	0,11
3509310320	CA	0 / 90 °C	Bulb in copper Ø6,5x66 mm Capillary 1m. 3 Faston	16 A	0,11
3509310321	CA	0 / 120 °C	Bulb in copper Ø6,5x66 mm Capillary 1m with PVC sheet. 3 Faston	16 A	0,11
3509310321/ESP	CA	0 / 120 °C	Bulb in copper Ø6,5x66 mm Capillary 1m. 3 Faston	16 A	0,11
3509310322	CA	0 / 200 °C	Bulb in S. Steel Ø5x98 mm Capillary 1m. 3 Faston	16 A	0,11
3509310322/ESP	CA	0 / 200 °C	Bulb in S. Steel Ø5x98 mm Capillary 1m with silicone sheet. 3 Faston	16 A	0,11
3509310323	CA	0 / 320 °C	Bulb in S. Steel Ø3x195 mm Capillary 1m. 3 Faston	16 A	0,11
517350000	CT1	0 / 90 °C	Bulb in copper Ø6x99 mm Capillary 1m. 2 Faston	20 A	0,06
517355000	Button + Face plate 0 / 90 °C				0,01
517352000	CT2	30 / 160 °C	Bulb in copper Ø6x88 mm Capillary 1m. 2 Faston	20 A	0,06
517357000	Button + Face plate 30 / 160 °C				0,01
517377000	TE	120 °C	Manual reset thermostat. Capillary 1m. Bulb in S. Steel Ø6x72 With M9x1 gland	16 A	0,12
517578000	TC	65 °C	Capillary 1m. Bulb in S. Steel Ø6x72 With M9x1 gland	16 A	0,12

NON-pluggable cane thermostats



Bulb and capillary thermostats to include in the Europa Range

Three-pole snap action thermostats. 2 to 13°C differential depending on temperate scales. Bulb and capillaries in stainless steel. Connection to 6.3mm fastons.

Code	Thermostat range	Range	Characteristics	MAXimum intensity (~240 V)	Weight in Kg
517370000	EG	1 / 40 °C	Bulb in copper Ø6x215 mm Capillary 880 mm	16 A	0,19
517370001	Botón escala 0 / 40 °C				0,02
517371000	EG	28 / 85 °C	Bulb in copper Ø6x129 mm Capillary 880 mm	16 A	0,19
517371001	Botón escala 30 / 85 °C				0,02
517372000	EG	36 / 125 °C	Bulb in copper Ø6x138 mm Capillary 880 mm	16 A	0,19
517372001	Botón escala 30 / 120 °C				0,02
517373000	EG	60 / 200 °C	Bulb in S. Steel Ø6x142 mm Capillary 880 mm	16 A	0,19
517373001	Button scale 60 / 200 °C				0,02
517374000	EG	50 / 300 °C	Bulb in S. Steel Ø6x77 mm Capillary 880 mm	16 A	0,19
517374001	Button scale 50 / 300 °C				0,02



Double action bimetallic thermostat

A lot of applications such as washer machines, dishwashers, water heaters, etc.

Code	Reference	Temperatures of action on the contacts	Maximum current (~250 V)
517257000	TER-Z01-NA35-NA65	Normally open: 35 °C Normally open: 65 °C	16 A
517258000	TER-Z01-NA35-NC82	Normally open: 35 °C Normally closed: 82 °C	16 A
517259000	TER-Z01-NA35-NC85	Normally open: 35 °C Normally closed: 85 °C	16 A

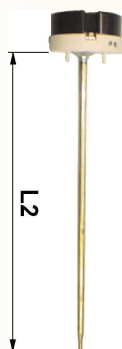

THERMOSTATS FOR MONOBLOCK

Description	Code	Thermostat range	Range	Max. current	L2 mm	Connection to element	Mains connection	Weight in Kg
TER-CO-137-0-90-F	517321000	A1	0-90	16 A	137	Faston 6,3	Barrilete	0,06
TER-CO-137-40-150-F	517323000	A2	40-150	16 A	137	Faston 6,3	Barrilete	0,06
TER-CO-270-30-90-F	517320000	B1	30-90	16 A	270	Faston 6,3	Barrilete	0,08
TER-CO-270-90-150-F	517322000	B2	90-150	16 A	270	Faston 6,3	Barrilete	0,08
TER-CO-280-10-80	517277000	E1	10-80	16 A	270	Faston 6,3	Barrilete	0,05
TER-AR-280-20-80-F	517311000	E3	20-80	15 A	280	Faston 6,3	Barrilete	0,05

Note 1: The thermostats of the "A" range may replace those of the "B" range, but they have a higher differential and lower accuracy.

Note 2: For water it is recommendable to use the thermostat up to 90 °C to avoid risk of accidental boiling.

Not PLUGGED rod thermostats



Single-pole rod thermostats. 5 to 10°C differential depending on temperature scales. Connection by leads through side inputs.

Code	Description	Thermostat range	Operation temperatures		Characteristics	Maximum current (~240 V)
			Control (Automatic reset)	Safety (Manual reset)		
517330000	TER-CO-165-0-80-NEF	NEF	0 / 80 °C	---	Sheath Ø7,5x165 mm	20 A
517335000	TER-CO-265-5-80-NEF	NEF	5 / 80 °C	---	Sheath Ø7,5x265 mm	20 A
517337000	TER-CO-265-45-120-NEF	NEF	45 / 120 °C	---	Sheath Ø7,5x265 mm	20 A
517358000	TER-CO-165-0-73-87-NEF	NEF	-10 / 73 °C	87 °C	Sheath Ø7,5x165 mm	20 A
517347000	TER-SV-280-45-95-NEF	NEF	---	45 / 95 °C	Sheath Ø7,5x280 mm	16 A

ACCESSORIES FOR BULB THERMOSTATS AND ROD THERMOSTATS

Code	Description
570004330	Mounting clip for bulb thermostat Ø _{nominal} 7,5 mm to sheath Ø _{int} 3,5 to 8 mm
570004331	Mounting clip for bulb thermostat Ø _{nominal} 6 mm to sheath Ø _{int} 3,5 to 7 mm
570004332	Mounting clip for bulb thermostat Ø _{nominal} 8 mm to sheath Ø _{int} 3,5 to 12 mm



A correct choice of setting and switch system material increases the results of the thermo-electrical elements and guarantees that the system works properly within the established working limits.

All Electricfor control and switch boards are designed to respond to European safety specifications.

Choice of whether the control board is a standard model or a made to measure model following specific specifications will depend largely on the following criteria:

- Type of control method
- Required setting accuracy

If its application refers to a high thermal inertia process (for example, heating of large water or oil tanks), an ACO- type control board with ALL/NOTHING settings by contactors may be the best solution.

If on the other hand your process consists in instantaneous heating of circulating fluid (for example, tankless heaters) or you require rapid reactions in the setting system with great accuracy of temperature control, then the most suitable control board for you will be an ACT-type with a power setting by thyristors.

Contact our technical service for them to help you choose the most suitable equipment for each application.

Apart from setting and switch boards, you will also find a wide range of both mechanical and electronic action thermostats, of ALL/NOTHING, PD and PID type on pages 128 of this catalogue.

ACO model control and switch boards. Power control by contactor (ALL-NOTHING)

- Board of an appropriate size for each range of power with IP-65 damp protection rating
- Control of one ALL/NOTHING power stage controlled by a remote thermostat
- Connection input for a safety thermostat
- Front running switch with door blocking and integrated fuses

Code	Voltage	Maximun nominal power, in KW	Dimensions in mm		
			High	Wide	Deph
ACO12	3N~400	12 kW	400	400	200
ACO27	3N~400	27 kW	400	400	200
ACO50	3N~400	50 kW	500	500	300
ACO61	3N~400	61 kW	500	500	300



ACT model control and switch boards. Power control by thyristor

- Painted steel board of an appropriate size for each range of power with IP-41 damp protection rating.
- 1 sectioner door blocking + general protection.
- 1 safety contactor (overheating of the process/internal overheating/external contact).
- 1 break thyristor on 3 phases (in the 3N~400 V versions) with RC varistors and circuits.
- Feed and outlets on terminal block.
- 1 PID adjustable temperature controller.

Code	Voltage	Maximun nominal power, in KW	Dimensions in mm		
			High	Wide	Deph
ACT8	~230	8 kW	300	300	250
ACT12	3N~400	12 kW	300	300	250
ACT22	3N~400	22 kW	400	400	250
ACT27	3N~400	27 kW	600	500	311
ACT51	3N~400	51 kW	600	500	311
ACT60	3N~400	60 kW	600	500	311
ACT86	3N~400	86 kW	600	500	311

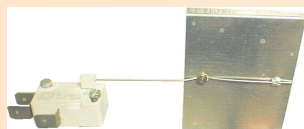

FLOW SWITCH, MODELS MR-2

Code	Description	Characteristics
517167000	FLOW SWITCH "MR-2"	Trip air speed approx.: 2 m/sec. Maximum ambient temperature: 40 °C



POWER REGULATOR, MODELS MR-1

Code	Description	Characteristics
517192000	POWER REGULATOR	Current: 2A 230 V. 500 W
517193000		Current: 6A 230 V. 1500 W
517194000		Current: 12A 230 V. 2750 W



ENERGY REGULATORS

Code	Description	Characteristics
517230000	ENERGY REGULATOR. (By means of percentage variations of ON / OFF periods of load circuit)	Energy Timer/Regulator
517230001	~200/240 V. 13 A	White button for energy regulator



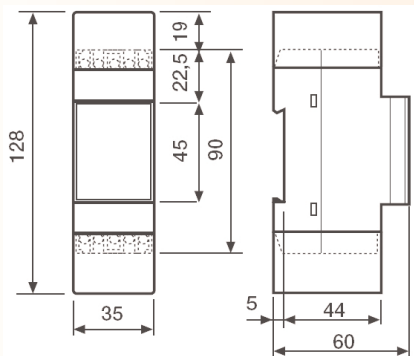

Code	Reference	Description
51736000	IHA0021	24 hours synchronous time switch - 2 DIN Din rail 35 mm. ~230 V, 50-60 Hz. Change over relay. 16 (4) A / ~250 V. Min switching intervals 30'. Time accuracy: ±5 min - 365 days IP30.
51736200	IHA0024	7 days quartz reserve time switch (150 hours) - 2 DIN Din rail 35 mm. ~230 V, 50-60 Hz. Change over relay. 16 (4) A / ~250 V. Min switching intervals 210'. Time accuracy: ±5 min - 365 days IP30.
51736500	IHD0080	Digital daily time switch 1 circuit (15 days) - 2 DIN Din rail 35 mm. ~230 V, 50-60 Hz. Change over relay. 16 (4) A / ~250 V. Min switching intervals 1". Time accuracy: ±1 sec / day 20 ON and 20 OFF over the channels. IP40.
51736600	IHD0081	Digital weekly time switch 1 circuit (15 days) - 2 DIN Din rail 35 mm. ~230 V, 50-60 Hz. Change over relay. 16 (4) A / ~250 V. Min switching intervals 1". Time accuracy: ±1 sec / day 20 ON and 20 OFF over the channels. IP40.

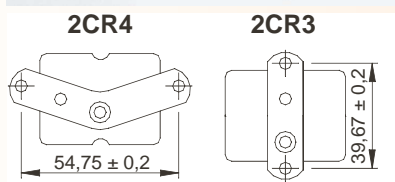

FASTONS POSITIONS FOR 2CR3 and 2CR4

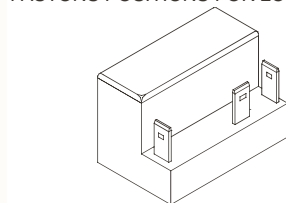

Designed for all position operation, the KLIXON® 2CR is a current-type motor starting relay which can be used on both split-phase and capacitor-start motors. It has broad application versatility which includes business and computing machines, power tools, food machinery, portable appliances and dishwashers.

The compact 2CR can be mounted and operated in any position, either in the motor or at a convenient location away from the motor. This allows motor size to be reduced since a space-consuming centrifugal switch is not required.

Pick-up and Drop-out ratings

Ratings indicate maximum pick-up and minimum drop-out current limits. Pick-up is the current through the relay coil required to close the relay contacts. Drop-out is the current through the relay coil at which the contacts open. A production relay of a given rating will have a pick-up and drop-out current within the rating limits.

Code	Faston's position	Maximum PIC UP	Minimum DROP OUT
(*) 2CR3140	Vertical	4,05 A	3,35 A
4CR1148	Vertical	4,85 A	4,00 A
(*) 2CR4160	Horizontal	6,10 A	5,05 A
(*) 2CR3170	Vertical	7,10 A	5,90 A
(*) 2CR4172	Horizontal	7,30 A	6,00 A
4CR1179	Vertical	8,00 A	6,60 A
(*) 2CR4195	Horizontal	9,60 A	7,90 A
(*) 2CR4204	Horizontal	11,00 A	9,10 A
(*) 2CR4215	Horizontal	13,20 A	10,90 A
4CR1223	Vertical	14,80 A	12,20 A
4CR2223	Horizontal	14,80 A	12,20 A
(*) 2CR4258	Horizontal	21,90 A	18,10 A

(*) **IMPORTANT:** The indicated models are going to extinct and will be replaced gradually by corresponding to the format 4CR2, maintaining the PIC UP and DROP OUT electrical characteristics.



LEGIONELUS 70 acts automatically by means of time cycles selected by the user. This carries out a periodic cleaning of the system by increasing the temperature of the installation over the determined time, guaranteeing a good sterilization of the conduits through which the water circulates and the ACS is accumulated.

Example: Every 7 days the installation maintains a temperature of 60 °C to 70 °C during two hours.

Usual applications

- House buildings.
- Laundries.

- Public centers of a large number of people: gymnasiums, schools, offices, hospitals, hotels, etc.

General characteristics

- Set point temperature indicator
- Adjustment set point temperature installation (T1)
- Regulation of the differential.
- Limitation interval temperature installation (T1) by minimum and maximum.
- Minimum time of disconnection between two connections of the charge of the installation (T1).
- Readjustment calibrated sensor.
- Selection temperature of Legionella elimination (T2), from 40 °C to 80 °C, factory 70 °C.
- Timer during cycle elimination, from 1 minute to 120 minutes. Factory 5 minutes.
- Repetition of the cycle every 1 to 168 hours (7 days), factory 24 hours.
- PIN, protection and blockage of the keyboard.

Technical data

- Range temperature 10 to 95 °C
- Power supply ~230 V (50 / 60 Hz)
- Type of sensor temperature PTC2000
- Dimensions of the sensor Ø6 x 30 mm
- Relay T1 10 (4) A ~250 V NC +NO
- Relay T2 10 (4) A ~250 V NO
- Regulation type ON / OFF
- Colour visualization Red
- Number of buttons 3



Code	Reference	Range
517340000	LEGIONELUS 70. Wall version	10 - 95 °C
517343000	LEGIONELUS 70 RAIL. Rail DIN version	10 - 95 °C

ALLEGRO 400 / FC200

GROUP 11 - Control and regulation

DIFFERENTIAL THERMOSTAT WITH PTC SENSOR, MODELS ALLEGRO 400

Control differential for capturing solar heat by means of solar paddles accumulating hot water, for sanitary hot water use or swimming pools.

General characteristics

- Indication collector temperature with decimals.
- Indication tank temperature with decimals.
- Possibility of forced operation.
- Possibility of forced stop.
- Calibrated adjustment of sensor
- Differential of activation.
- Defrosting Yes / No
- Connection without sensor polarity.
- 2 temperature sensors (IP67)
- PTC2000.
- Password

Technical data

- Range temperature -40 to +140 °C
- Power supply ~230 V (50 / 60 Hz)
- 1ª Temperature sensor (IP67) PTC2000 1,5%
- 2ª Temperature sensor (IP67) PTC2000 1,5%
- Dimensions of the sensor Ø6 x 30 mm
- Relay (NO + NC) 12 (5) A ~250 V
- Regulation type ON / OFF
- Colour visualization Red
- Number of buttons 3
- N^{er} of programmable param. 5
- Working temperature -5 to +55 °C
- Storage temperature -20 to +60 °C
- Block of parameters by password Yes

ALLEGRO 400

INSTALLATION EXAMPLE

1. Solar collector.
2. Accumulating tank.
3. Interchanging coil.
4. ALLEGRO 400 Regulator
5. Exit sensor collector.
6. Exit sensor tank.
7. Circulation pump.
8. Glass expansion.
9. Heating element.
10. Cool water - In.
11. Hot water - out.
12. Thermostat

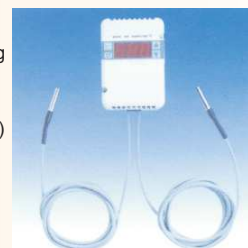
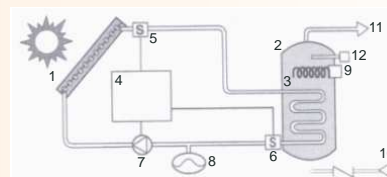

Código	Reference	Range
517341000	ALLEGRO 400. Wall version	-40 ... +140 °C
517344000	ALLEGRO 400 RAIL. DIN rail version	-40 ... +140 °C
517345000	ALLEGRO 433 RAIL. DIN rail version. 3 Sensors, 3 relays	-40 ... +140 °C

DIFFERENTIAL THERMOSTAT, MODELS FC200

Differential regulator for taking advantage of the outside air and to climatise shops, houses or offices by means of ventilation. Also it can be used in dryers.

INSTALLATION EXAMPLE

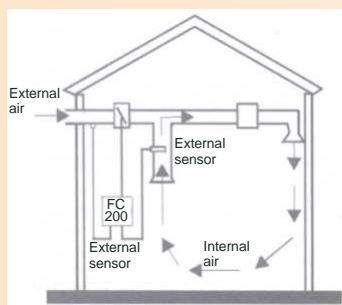

General characteristics

- Indication impulse temperature.
- Indication return temperature.
- Possibility of forced operation.
- Possibility of forced stop.
- Calibrated adjustment of sounding.
- Differential of activation.
- 2 temperature sensors

Technical data

- Range temperature -40 to +140 °C
- Power supply ~230 V (50 / 60 Hz)
- 1ª Temperature sensor (IP67) PTC2000 1,5%
- 2ª Temperature sensor (IP67) PTC2000 1,5%
- Dimensions of the sensor Ø6 x 30 mm
- Relay (NO + NC) 12 (5) A ~250 V
- Regulation type ON / OFF
- Colour visualization Red
- Number of buttons 5
- N^{er} of programmable param. 7
- Working temperature -5 to +55 °C
- Storage temperature -20 to +60 °C
- Block of parameters by password Yes

FC200

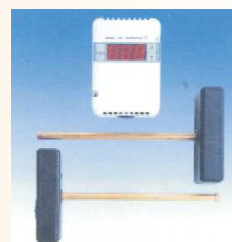

Code	Reference	Range
517342000	FC 200. Differential regulator. Wall version	-40 ... +140 °C
517346000	FC 200 RAIL. Differential regulator. DIN rail version	-40 ... +140 °C
517342001	SFC 200. Sensors spare parts	-40 ... +140 °C



The majority of elements for measuring temperature are based on dilation of a solid, liquid or gas (thermostats and thermometers of mechanical action as for example bulb thermostats, klixon®, etc), or a thermo-electric measurement in which an induced electro-driven force is translated into a temperature (thermocouples) or in the measurement of an ohmic value change of an element caused by a temperature change (resistance temperature detector PT100, NT, PTC)

Thermocouples

Thermocouples are the widest used elements of all electric temperature sensors. There are manufactured in a wide range of configurations and offer the user maximum flexibility.

A thermocouple consists of a pair of conductors of different metals connected at one end. Their functioning is based on the Seebeck effect. This is based on the apparition of a voltage or electro-drive force owing to the difference in temperatures between two unions of different metals in the same circuit. The temperature/tension characteristics of a thermocouple depend as much on the materials used in its composition as on the temperature to which they are subjected. In the following table, different types of thermocouple are shown, designation according to their corresponding standards and the polarity of the metals.

Type	Material and polarity		Designation		Temperature range in °C	Margins of error
	(+)	(-)	IEC, ISA, ANSI	DIN		
T	Copper / Copper-nickel		Copper - Constantan	Cu - Cu Ni	-200 ... +0 °C 0 ... +350 °C	± 1°C or ± 1,5% ± 1°C or ± 0,75%
J	Copper / Copper-nickel		Iron - Constantan	Fe - Cu Ni	0 ... +760 °C	± 2,2 °C or ± 0,75%
E	Nickel-Chrome / Copper-nickel		Chromel - Constantan		-200 ... +0 °C 0 ... +870 °C	± 1,7°C or ± 1% ± 1,7°C or ± 0,5%
K	Nickel-Chrome / Nickel-Aluminium		Chromel - Alumel	Ni Cr - Ni Al	-200 ... +0 °C 0 ... +1250 °C	± 2,2°C or ± 2% ± 2,2°C or ± 0,75%
R	Platinum-Rhodium 13% Platinum		Pt 13 Rh - Pt		0 ... +1450 °C	± 1,5 °C or ± 0,25%
S	Platinum-Rhodium 6% Platinum		Pt 10 Rh - Pt	Pt10 Rh - Pt	0 ... +1700 °C	± 0,5%
B	Platinum-Rhodium 30% Platinum-Rhodium 6%		Pt 30 Rh - Pt 6 Rh		+870 ... +1700 °C	± 0,5%

Resistance temperature detectors (RTD)

The principle of temperature measurement by resistance is based on the capacity of the metals to vary their resistivity depending on the temperature. This capacity is more or less emphasised depending on the material used.

For greater accuracy when measuring temperature, materials must be found that contain a high variation of ohmic value. This is best achieved with pure metals. The most widely used are nickel (Ni) and especially platinum (Pt). Within the temperature range of -200°C to +750°C, RTD's are the most accurate method, as the temperature variations can be measured with great exactitude. Calibrated resistances provide measurements with an accuracy of ± 0.02 °C in the temperature range of -50 °C to +150 °C.

The most common RTD's are the Pt100. They must have an ohmic value of 100 W at 0°C, with a tolerance of ± 0.1 W. Other types of RTD's used are the NTC (materials which decrease their ohmic values when the temperature increases) and the PTC (when the temperature increases, their ohmic value increases)

Standard heads for thermocouples and RTD's

The following figures show us the most common DIN standard heads according to DIN or ASA standards. Materials used in construction of these heads tends to be plastic for the BBK type; aluminium for the DIN A and DIN B; brass for the S type; and cast iron or aluminium for the NEMA IV type.



Types of probes according to finishes

• **Probes with sheath and head:** They are characterised by having a robust structure and the connection of the compensated lead is located in the head. They can have a moving nipple, flange, etc.

• **Bayonet type probes (fast connecting):** Their characteristics consist in determining a measurement by sliding the bayonet over a spring and adjusting by means of a quarter of a turn of a special nipple. They are usually applied in holes.



• **Hammer type probes (elbowed probes):** They tend to be small in size. The elbow is of 90°, whether with thread or else with bayonet, with appendix, etc. Their most frequent application is designed for mould plates, small moulds, etc.



• **Thread probes:** This system is recommend for any connection where good tightness needs to be assured and therefore a greater security of measurement.



• **Band type probes:** Band sensors are ideal for measuring in piping and cylinders. The diameter and width must be determined depending on the application.

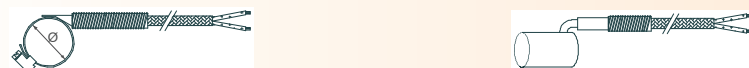

• **Surface probes (for flat surfaces):** They take the superficial temperature on plates, blocks, etc. Their connection is ensured with a tightening screw



• **Capillary probes:** They are probes with a very small diameter (from Ø0.5 mm), ductile and mouldable. They adapt to any geometric shape.









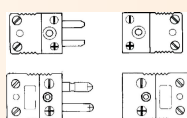



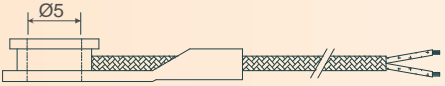



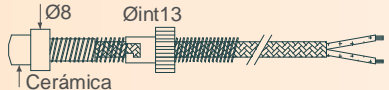

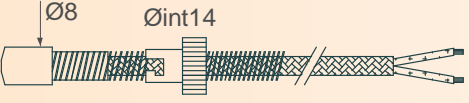
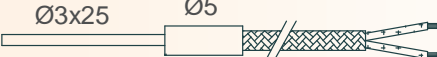
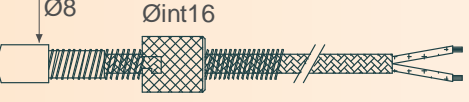

Polarised compensated connectors

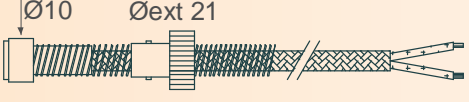
Connections for all types of thermocouples and RDT's.

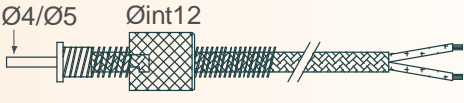

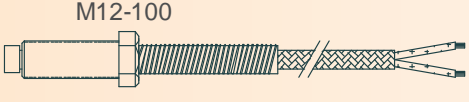

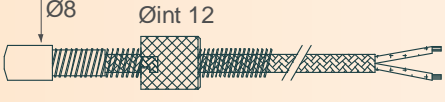





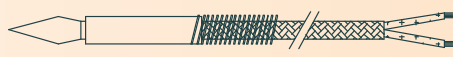



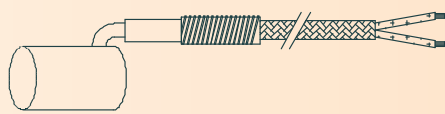
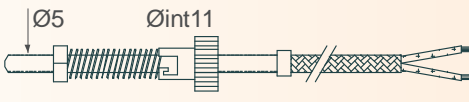

Connector material in plastic, and ceramic for high temperatures. Maximum working temperature 425°C for plastic ones and 650°C for the high temperature ones. Standard model with round terminals.

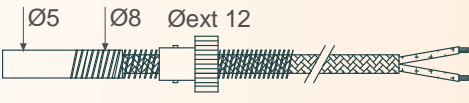
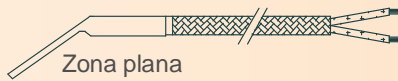

General sensor's index - 1

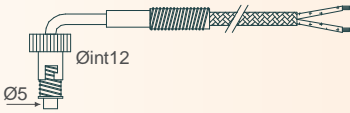
<p>MAQUIPLAS JUNGUERFRE</p> <p>1</p>		<p>MATEU SOLE SOMAR</p> <p>13</p>	<p>1/4-G int</p> 
<p>PHILIPS</p> <p>2</p>		<p>MONOMAT</p> <p>14</p>	<p>Ø6</p> 
<p>PHILIPS BEKUN</p> <p>4</p>		<p>GBF</p> <p>15</p>	<p>Ø3x15</p> 
<p>5</p>		<p>16</p>	<p>Ø3x25 Ø5</p> 
<p>6</p>		<p>17</p>	<p>Ø5</p> 
<p>GBF</p> <p>7</p>	<p>M10-100</p> 	<p>19</p>	<p>Ø6 Øint12</p> 
<p>KRAUSS MAFFEI</p> <p>8</p>		<p>20</p>	
<p>MATEU SOLE MORETTI</p> <p>9</p>	<p>M6-100</p> 	<p>KLOCKNER KRAUSS MAFFEI</p> <p>21</p>	<p>Ø4/Ø5 Øint12</p> 
<p>MARGARIT</p> <p>10</p>	<p>M14-150</p> 	<p>KLOCKNER</p> <p>22A</p>	<p>M8</p> 
<p>GBF MATEU SOMAR</p> <p>11</p>	<p>M12-100</p> 	<p>23</p>	<p>Ø8</p> 
<p>12</p>		<p>NESTAL</p> <p>24</p>	

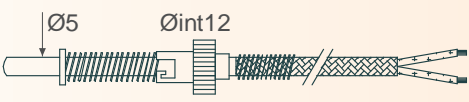
General sensor's index - 2

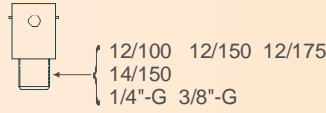
25	 <p>Ø x L</p>	AMBIENTE	
26	 <p>Ø7 Øint12</p>	ROSCA FIJA	
27	<p>NESTAL</p> 	ROSCA MÓVIL	
28	 <p>Ø</p>	39	
29	<p>SINDEL ANDOUART SAMAFOR</p>  <p>Ø5 Øint11</p>	40	
30	<p>SANDRETO MIR. - IMI NEGRIBOSI</p>  <p>Ø5 Ø8 Øext 12</p>	41	 <p>Zona plana</p>
31	 <p>Ø5 Øint11</p>	42	
32		43	
33	<p>MAURER</p>  <p>Ø5 Øint12</p>	44	
34	 <p>Ø5 Øint12</p>	44M	
35	 <p>Ø4</p>	PORTA BAYONETAS	 <p>12/100 12/150 12/175 14/150 1/4"-G 3/8"-G</p>

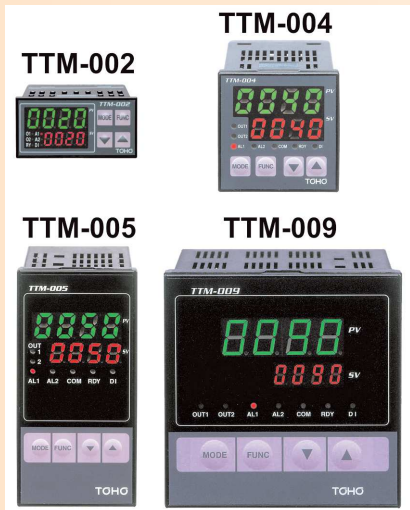

DIGITAL CONTROLLERS TTM-000 SERIES

Versatile Digital Temperature Controller with various functions and easy operations. It is a compact size; the depth is only 77mm. If the communication option is selected, the distance is extended up to 500 meters, and maximum 31 units of controllers can be connected with a computer at a same time, and the centralized supervision can be performed.

Sampling cycle is 500msec (S grade is 250msec).

General characteristics

- **Self-Tuning PID:** Most appropriate PID constant is automatically reckoned up for control objects. PID constant is calculated when making alteration of setting value, or it is corrected when occurring disturbance/hunting etc.
- **PID Over-Shoot Protection:** It is functional to inhibit PID Over-Shoot.
- **Simplified Timer:** ON/OFF setting control is available after some certain interval. Function of ON/OFF alarm output is independently usable.
- **Multiple Inputs:** Thermocouple/R.T.D. (Pt 100 & JPt 100) are selectable by front key.
- **Manual Control (Balanceless & Bumpless):** Manual output function is applicable for versatile applications of instrumentation systems.
- **Heating/Cooling Control:** PID control is available on cooling side.
- **Digital PV Filter:** For abrupt alteration of input value, filter effect is operational on software.
- **Communication Function (RS-485 : TOHO protocol/MODBUS):** The communication distance is extended up to 500 meters, and maximum 31 units of controllers can be connected with a computer at a time. Centralized supervision is available for collection of the whole data and alteration of setting values at remote location.
- **Compact Size:** It is a compact size. The depth is only 77mm! (95mm for TTM-002)
- **DI (Digital Input) Functions:** The following functions are selective.
 - 1.- SV/SV2
 - 2.- RUN/READY
 - 3.- Automatic (RUN)/Manual
 - 4.- Normal/Reverse Action
 - 5.- Normal (SV2)/Reverse Action (SV)
 - 6.- AT (Auto-Tuning) Start
 - 7.- Timer, Start/Reset
- **Standardization of Conformity** UL, cUL, CE, & IP 66 approved. ("S" Grade is under approval)

Dimensiones

TTM-002	24x48 mm
TTM-004	48x48 mm
TTM-005	96x48 mm
TTM-009	96x96 mm

Ordering Information (Model Configurations)

TTM -

Model	Grade	Input	Output 1	Option

Model	002	24X48mm	1/32 DIN		
	004	48X48mm	1/16 DIN		
	005	96x48mm	1/8 DIN VERTICAL		
	009	96x96mm	1/4 DIN		
Grade	-	Normal Grade (Sampling Time : 500mS)			
	S	"S" Grade (Ramp function & Sampling Time : 250mS) Not available in TTM-002			
Input		Thermocouple (K, J, T, R, N, S, B), R.T.D. (Pt100, JPt100)			
	2	4...20 mA - 0.5Vdc - 1/5 Vdc			
Output 1	R	Relay contact			
	P	SSR 12 Vcc			
	I	4...20 mA			
Option	-	None			
	B	Output 2	Relay or EV2		
	P	Output 2	SSR		
	R	EV2	Relay contact TTM-002/004 : Not optional TTM-005/009 : Not available when DI is selected		
	D	Input CT	Not provided when I is selected for Output 1. TTM-002/004 : Not provided when DI is selected		
	E	DI (Digital input)	TTM-002/004 : Not usable when CT is selected TTM-005/009 : Not obtained when EV2 is selected		
	M	Communication	RS-485 (TOHO protocol) Available when Normal Grade is selected		
	X	Communication	RS-485 (TOHO protocol + MODBUS) Available when "S" Grade is selected.		
	H		0/10 mVdc		
	K		0/1 Vdc		
	J	Transfer Output	0/5 Vdc		
	F		1/5 Vdc		
	G		0/10 Vdc		
	I		4...20 mA		

- Notes:**
- "A (EV1 : Alarm 1)" provided for in the standard specifications.
 - Without output 2, EV2 is not available. Output 2 is equally used as EV2, but not activated simultaneously. Model Grade Input Output 1 Option
 - Transfer Output (H, K, J, F, G, I) is only available in "S" Grade.
 - Communication "X" (TOHO protocol + MODBUS) is only available in "S" Grade.
 - Option of "M" & "X" can not be selected at the same time.





General characteristics

- **Accuracy:** 0,2 % ± 1 °C (Tamb = 25 °C)
- **Input:** Configurable (Pt 100, J, L, K, S, mA, Volt).
- **Control mode:** On/Off, PID.
- **AutoTuning:** For automatic adjustment of optimum control parameters.
- **Main output:** Configurable. Logic or relay, single or dual.
- **Auxiliary output:** With relay, configurable.
- **Indication:** Simultaneous display of measurement and Set point.
- **Access to parameters:** On 3 different levels for: modification, display only, and no-access.

- **Loop break alarm.**
- **Standard voltage:** 100...240 Vdc switching type, or 24 Vac and 24 Vdc.
- **Auxiliary power supply for external transmitter:** 24 Vdc.
- **Front protection:** Standard IP54, IP65 with optional front panel gasket.
- **Withdrawable front**
- **Dimensions:** 48 x 96 DIN depth 120 mm.
- **Options:**
 - Serial communication to computer.
 - 2nd auxiliary output (extra).

BASIC MODEL IN PERMANENT STOCK:

XE-301: Configurable multi-input controller series XE standard voltage ~230 V 50/60 Hz, with 1 main output logical or relay, and 2 auxiliary outputs of relay. Serial communication to computer NOT FITTED.

Borehole panel: 45+0,6 x 22,2+0,3 mm

DIMENSIONS

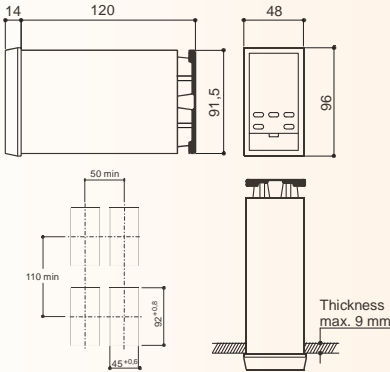

Coding mode

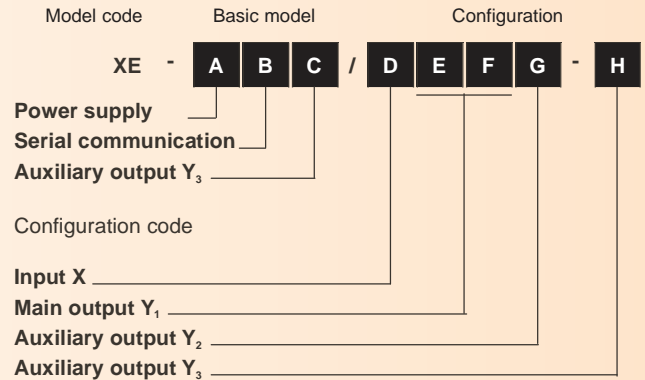

Power supply	A
100 ... 240 Vac 50/60 Hz (stock)	3
16 ... 28 V 50/60 Hz y 20 ... 30 Vdc	5

Serial communication	B
Not fitted (in stock)	0
Fitted	1

Auxiliary output Y ₃	C
Not fitted	0
Fitted (in stock)	1

Input type, scale range	D		
RTD			
IEC 751	Pt100 -200...600 °C	0	
	Pt100 -99,9...300,0 °C	1	
	J 0...600 °C	2	
	L 0...600 °C	3	
Thermocouple	K 0...1200 °C	4	
IEC 584	S 0...1600 °C	5	
	4...20 mA	Configuration eng. units	6
	0...20 mA	Configuration eng. units	7
	0...1 Vdc	Configuration eng. units	8
	0...10 Vdc	Configuration eng. units	9

Output type Y ₁	E
Relay (On - Off with hysteresis)	0
Relay with time proportioning	1
Logic 0/18 Vdc with time proportioning	2
Relay with time proportioning (*)	6
Logic 0/18 Vdc with time proportioning (*)	7

(*) For Heat / Cool controllers, select outputs E-6 or E-7

Type of action and safety state Y ₁	F	
Reverse	Safety 0%	0
Direct	Safety 0%	1
Reverse	Safety 100%	2
Direct	Safety 100%	3
Reverse	Safety -100% (*)	4
Direct	Safety -100% (*)	5

Type of set point and control mode output Y ₂	G	
Disabled	0	
Deviation with startup inhibition	Active high	1
	Active low	2
Band	Active out	3
	Active in	4
Independent	Active high	5
	Active low	6
Deviation	Active high	7
	Active low	8
Loop break alarm	9	

Type of set point and control mode output Y ₃	H	
Disabled	0	
Deviation with startup inhibition	Active high	1
	Active low	2
Band	Active out	3
	Active in	4
Independent	Active high	5
	Active low	6
Deviation	Active high	7
	Active low	8
Cool - Heat	9	

Electronic temperature controller panel, specific to refrigeration. NTC sensor included.

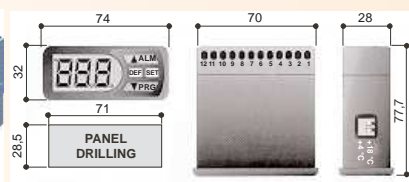

Technical characteristics, CTX031N00 series

- ON / OFF regulation
- Relay output 8(2)A ~250 V
- Accuracy ± 1 digit
- Sensor accuracy ± 2%
- Front dimensions 32 x 74 mm
- Working temperature 0 - 50 °C
- Protection: IP52 on front panel, IP20 for terminals
- Power supply ~230 V

Code	Reference	Range	Sensor type
3501020449	CTX031N00	-45 ... 50 °C	NTC





Registrador con puerta transparente STD-99, protección IP-42

Graphic data logger, SRD-99 model

The SRD-99 low cost, high performance data logger has been designed for displaying and logging temperature, pressure, humidity, level, PH, redox, current, etc. It comes with 8 temperature or current inputs (P100/500/100) in the standard 0/4÷20mA, one digital input, a USB port for storing data and communications port RS-485 MODBUS RTU. The SRD-99 also has an internal 2MB capacity memory (500,000 data collection) and 8MB in the version with USB port (2000000 recorded data).

and 8MB in the version with USB port (2000000 recorded data).

The internal analogue digital converter has a 16bit resolution which gives extremely high reading accuracy. It also has alphanumeric description (text) for each channel. It is simple and intuitive to programme, either by keypad or software.

There is a choice of graphic display; numerically with digital display of 18mm and linear representation bar, display of the 8 inputs and their corresponding value on the same screen, history of the process in terms of time, etc.

The new version of the SRD-99 also includes two relay outputs 24Vac (35Vdc) 200mA. The main function of the relay outputs is to indicate critical situations, although due to the large amount of programmable functions in the device the relay outputs can also be used for control and regulation applications.

The relay output status is shown through two fields described as R1 and R2 located on the upper left of the device's LCD screen.

The LoggySoft software included with the equipment means it can be configured as well as display, save and print readings stored in the internal memory of the SRD-99.

- USB Host port for storing data and configuration transfer by flash memory.
- Graphic display of 128x64 points, backlit quartz crystal.
- Independent graph for input channel.
- Free configuration and registration of software.
- RS-485 opto-isolated communication interface.

Technical features

- **Mains power supply:** 19/50 Vdc; 16/35 Vac or 85/260
- **Consumption:** Typical 7VA, max 12 VA
- **Display:** lit, LCD, 128x64 points, with feedback.
- **Measurement inputs:** 1, 4 or 8; Pt100; Pt500; Pt1000 (2 and 3 thread connections); current inputs 0/4...20mA; connection to common earthing.
- **Measurement range:** ±9999 + decimal point (current inputs); -100 °C / +600 °C (RTD inputs) with 0.1 °C resolution.
- **Digital inputs:** 1 entry 24 Vdc opto-isolated.
- **Outputs:** 2 electronic relays (ER1 / ER2). Maximum load 24 Vac (35 Vdc) / 200 mA
- **Supply for external sensors (for current inputs only):** 24 Vdc ± 5% / 200 mA

- **ICommunication interface:** RS-485 (MODBUSRTU) or USB port, isolated galvanically.
- **Transmission speed:** 1200 - 115200 bit/sec
- **Internal memory capacity:** 2 MB (500,000 data); 8 MB (around 2,000,000 data) in the version with USB port.
- **Protection type:**
Version with USB: a) IP-40 from the front. b) IP-65 from the front adding a frontal protection.
Version without USB: c) IP-20. d) IP-42 assembling the STD-9 front cover with password protection, accessory.
- **Working temperature:** 0 / 50 °C
- **Box material:** NORYL - GFN2SE1
- **Dimensions:** 96 x 96 x 100 mm
- **Installation depth:** 102 mm minimum.

Encoding mode

SRD-99- 2 8 - 1 - 1

Número de entradas
1
4
8

Tipo de entrada:
1 : 0...20 mA
4 : RTD (Pt100, Pt500, Pt1000)

Opciones
00 : Sin opciones
01 : IP65 (versión sin USB)
0B : Puerto Host USB con funda protectora
0J : Caja transportable P130

Alimentación:
3 : 19/50 Vdc
16/35 Vac
4 : 85/260 Vac/dc

Optional accessories



Transparent door

Transparent door with moulded frame according to DIN 43700; Lock with security key; sealing system IP42 DIN 40050 compliant. It also has a rubber gasket around the frame. The front framework is fully interchangeable. The closed units cannot be handled by non-authorized staff.



USB / RS-485 converter
Code: **SRS-U/4-Z45**



Converter RS-232 / RS-485
Code: **SRS-2/4-Z45**



Mini USB Stick
Mini memory stick USB with up to 8GB storage. Dimensions 31.3 x 12.4 mm.



Code: **STD-99**

Transportation box (front USB Host, without alarm connections)
Código: **P130**

Loggy Soft free software

1.- Loggy Soft

The software provides display, storing and printing of the dimensions (temperature, humidity, pressure, etc.) in the SRD-99 memory.

The SRD-99 logger and the Loggy Soft software communicate through RS-485 by connecting this network to the serial port (RS-232) or USB port of a PC through the converter (RS-485 a RS-232 or RS-485 to USB).

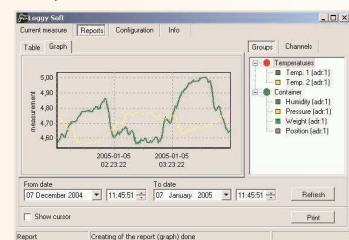

2.- SRD Toolkit

The SRD Toolkit software enables configuration and writing/reading operations. It updates the equipment's firmware and obtains basic information from the SRD-99 type by interface serial RS-485. This application means the equipment's parameters can be defined quickly and easily. The set of parameters can be transmitted directly to the equipment or stored in a file for later use.

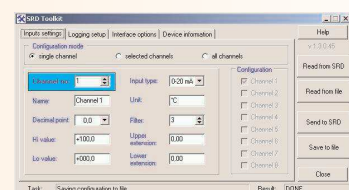

Codes:
M-USB-2G
M-USB-4G
M-USB-8G



Compact multi-use controller with logging functions, MultiCon models

MultiCon CMC-99 and CMC-141 is a compact multi-use controller /logger. It is one of the first industrial units on the market that includes advanced control strategies (PID, ON/OFF, ramp programmer), logic control, etc. Based on LINUX operating system it is perfect for applications when dimensions need to be taken simultaneously and action taken on various control outputs.

There are up to 48 analogue inputs, 16 relays or SSR outputs and 8 current outputs 4...20 mA. It has a TFT display and a tactile function. Designed with interface RS-485, Modbus-RTU protocol. It also has two USB ports:

Keypad or mouse connection and communication to PC. The CMC-99 can be ordered in two supply versions: 230V or 24Vac/dc. It has an extra output to supply external transmitters at 24Vdc / 200mA. A communication module can be attached (Ethernet, second USB host, second RS-485 and RS-232) and other types of inputs/outputs.

Its data storage internal memory is 1.5 GB which means 50 days running can be logged, with all input channels with a frequency of 1 second (total 250,000,000 data)

- Display TFT de 320x240 pixels
- Linux operating system
- Control of multiple outputs from a single input value
- Control of outputs from a logical combination of various inputs
- Direct connection to external sensors
- Direct connection to external actuators
- PID controller
- Flexible display mode: number, graph, bar chart, etc.

Technical features

- **Mains supply:** 19/50 Vdc; 16/35 Vac or 85/260 Vac/dc
- **Consumption:** Typical 15VA, max 20 VA
- **Display:** 3.5" TFT, 16 bit colour, 320 x 240 pixels, tactile.
- **Inputs:**
 - 48 analogue inputs (4...20mA or 0...10V) max
 - 12 universal inputs (V/I/RTD/TC/mV/R) max.
 - 24 thermocouple inputs, maximum
 - 12 RTD inputs, maximum
- **Digital inputs:** 1 input 24 Vdc
- **Outputs:**
 - 8 analógicas (4...20 mA)
 - 16 relés (1A/250V o 5A/250V) / SSR max
- **Internal memory capacity:** 1.5 MB, up to 250,000,000 data
- **Communication interface:**
 - Standard: RS-485 (MODBUS RTU), 1 x USB
 - Host (back), USB device
 - Improved version: (Inc. module ACM) 2 x RS 485, 1 x RS-485/RS-232, 1 or 2 USB Host, 1 x

optocoupled.

USB device, 1 x Ethernet 10 MB

- **Type of protection:**
 - Standard version: a) IP-40. b) IP-42 adding the STD-9 front cover. c) IP-65 adding a frontal protection.
 - Version with front USB: a) IP-40. b) IP-42 adding the STD-9 front cover.
- **Working temperature:** 0 / 50 °C
- **Storage temperature:** -10 / 70 °C
- **Assembly:** By panel
- **Box material:** NORYL - GFN2SE1



Encoding mode

MultiCon CMC- XX-P/D/C/B/A-XX1

Version:
 99: 96 x 96 mm
 141: 144 x 144 mm
 Slot P:
 Alimentación
 Slot D:
 Puerto interface

Opciones
 00 : Sin opciones
 01 : IP65
 0B : USB Host frontal. IP40
 Slot A: Módulo I/O
 Slot B: Módulo I/O
 Slot C: Módulo I/O

Module	Description	MultiCon CMC-99					MultiCon CMC141				
		Slot P	Slot D	Slot C	Slot B	Slot A	Slot P	Slot D	Slot C	Slot B	Slot A
PS3	Supply: 19/50 V _{ac} , 16/35 V _{dc}	x					x				
PS4	Supply: 85/260 V _{ac/dc}	x					x				
E	WITHOUT communication module (dispon available only for option 0B)		x					x			
USB	USB Port		x					x			
ACM	Advanced communication module: including: 1xRS485, 1xRS485/232, 1xUSB Host, 1xEthernet 10MB		x					x			
E	Empty								x	x	x
UN3	3 x Universal input (U/I/RTD/TC/mV)			x	x	x			x	x	x
UN5	5 x Universal input (U/I/RTD/TC/mV)								x	x	x
UI4	4 voltage input + 4 current input			x	x	x			x	x	x
UI8	8 voltage input + 8 current input			x	x	x			x	x	x
UI12	12 voltage input + 12 current input								x	x	x
UI6	16 voltage input			x	x	x			x	x	x
U24	24 voltage input								x	x	x
I16	16 current input				x	x	x		x	x	x
I24	24 current input								x	x	x
RT4	4 RTD input			x	x	x			x	x	x
RT6	6 RTD input								x	x	x
TC4	4 TC / mV input			x	x	x			x	x	x
TC8	8 TC / mV input			x	x	x			x	x	x
TC12	12 TC / mV input								x	x	x
D8	8 digital input			x	x	x			x	x	x
D16	16 digital input			x	x	x			x	x	x
D24	24 digital input								x	x	x
CP4	4 pulse input (universal counter)			x	x	x			x	x	x
FT4	4 pulse input + 4 current input			x	x	x			x	x	x
F4	4 voltage input + 4 current input			x	x	x			x	x	x
R81 (*)	8 x SPST relay 1A			x	x				x	x	x
R121	12 x SPST relay 1A								x	x	x
R45 (*)	4 x SPST relay 5A			x					x	x	x
R65	6 x SPST relay 5A								x	x	x
S8	8 x SSR output			x					x	x	x
S16	16 x SSR output			x					x	x	x
S24	24 x SSR output								x	x	x
IO2	2 x 4...20mA output			x	x				x	x	x
IO4	4 x 4...20mA output			x	x				x	x	x
IO6	6 x 4...20mA output								x	x	x

(*) The output modules R81 and R45 for model CMC-99 must only be installed in slot B. If 2 relay output modules are needed, the modules must be installed in slots B and C.

Optional accessories

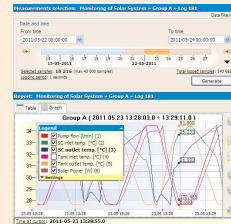

Optional software for PC

The DAQ Manager software enables the dimensions to be recorded graphically or in tables. Results can be printed or exported to other formats such as EXCEL.

DAQ Manager can be delivered in a CD (Software Box) or downloaded directly from the webpage www.simex.pl.



Transparent door

Transparent door with moulded frame according to DIN 43700; lock with security key, IP42 sealing key DIN 40050 compliant. It also has a rubber gasket around the frame. The front frame is fully interchangeable. The locked units cannot be handled by non-authorized staff.

Code:STD-99



Mini USB Stick

Mini USB memory stick of up to 8GB storage. Dimensions de 31.3 x 12.4 mm.

Códigos:

- M-USB-2G
- M-USB-4G
- M-USB-8G

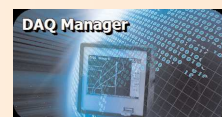

DAQ Manager Software Box.





Solid state relays, Okpac® models

These innovative and highly efficient components are used to control all kinds of loads in different industries. They are most commonly used in industrial heating and temperature control, as well as in the public and industrial lighting sectors.

Innovation

- Screw connection up to 50mm²
- Multiple, simple and fast connections
- IP20 protection covers
- Single screwdriver
- Attached on metal not plastic base
- Unpluggable control terminals.
- Diagnosis of the load, network and relay status
- Less resin used: environmental protection

Features

- Relays adapted to any kind of load
- TMS² fourth generation technology with an even longer life expectancy
- Switching voltage from 24 to 690VAC (with peak voltage 600V-1200V-1600V)
- Weak synchronism level
- Large AC-DC range with regulated input
- Optimised CEM (reduced electromagnetic emissions)
- UL/cUL, VDE (EN60950), IEC/EN60947-4-3 and EC marking
- Overloads in current up to 2000A - I_t>20 000A²s
- Possible protection by breaker

Usual applications

- Industrial furnaces
- Welding machinery
- Machinery for plastic or rubber injection
- Coffee machines
- Medical equipment
- Machinery for the textile industry
- Industrial and home lighting
- Packaging machinery

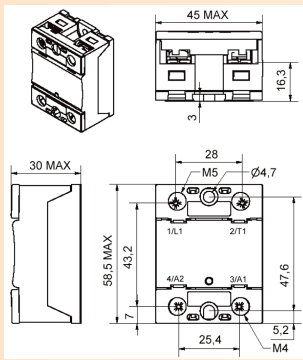

S08 / S09 ranges

Designed for most loads.

- S09 models: typical application resistive loads
- Synchronous with weak synchronism level (<12V) for S08 range
- Voltage protection in input (transil) with very high immunity, compliant with IEC/EN61000-4-4
- IP20 protection
- Current control <13mA for the whole voltage range in any operating temperature
- Display LED

Standard models S08 range

Code	Dimensions in mm	Output current	Output voltage	Control voltage
SO865970	45 x 58,5 x 30	50 A	24-510 Vac	20-265 Vac/dc
SO867070		75 A	24-510 Vac	3,5-32 Vdc
SO867970		75 A	24-510 Vac	20-265 Vac/dc
SO868070		95 A	24-510 Vac	3,5-32 Vdc
SO868970		95 A	24-510 Vac	20-265 Vac/dc
SO869070		125 A	24-510 Vac	3,5-32 Vdc
SO869970		125 A	24-510 Vac	20-265 Vac/dc
SO965460		50 A	24-600 Vac	3,5-32 Vdc
SO967460		75 A	24-600 Vac	3,5-32 Vdc

Esquema típico de aplicación

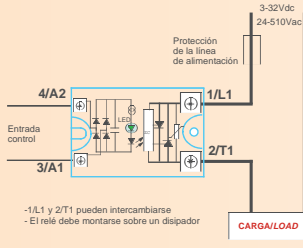

These products should be assembled on a thermal dissipater to obtain nominal values.

Thermal dissipaters, WF range

Code	Thermal characteristics	Specifications	Dimensions in mm	Installation	Figure nº
WF031100	0,3 KW	Ventilated by DIN rail or screw	110x120x145	SO /SGT	1
WF050000	0,55 KW	Optional DIN rail adapter	110x100x200	SO /SGT	2
WF070000	0,75 KW	Optional DIN rail adapter	110x100x100	SO /SGT	3
WF115100	0,9 KW	DIN rail or screw	110x100x90	SO /SGT	4
WF121000	1,2 KW	DIN rail or screw	100x40x100	SO /SGT	6
WF151200	2,2 KW	DIN rail or screw	45x73x80	SO	8

The R_{th} values shown correspond to a temperature increase of 50 °C in stable air. Other lengths available on demand.

DIN rail adapters

Code	Description
1LD00400	Adaptator DIN rail WF050000/ WF070000
1LD00500	Adaptator DIN rail SGT
1LD12020	Adaptator DIN rail SO vertical installation

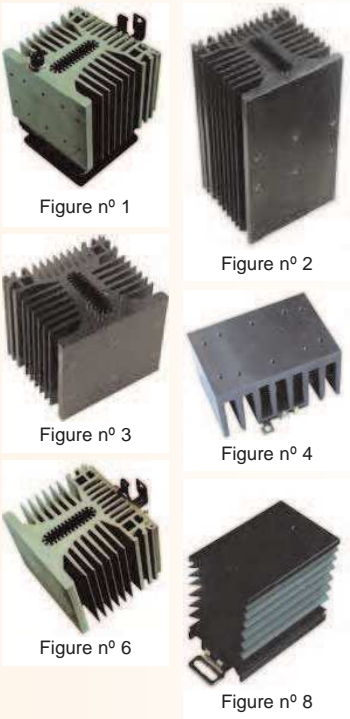



SO4 range, single phase proportional controllers

Static relay with analogue input that enables power control for resistive loads through phase angle variation.

- Current range: 35 to 125 A
- Protection of over voltage through integrated varistor
- Frequency range: 40 to 70 Hz self-adaptable
- Supply 8-30 Vcc, with green display LED
- Analogue input 0-5 V
- Compliant with EN60947-4-3 (IEC947-4-3) standards and EN60950/VDE0805 (reinforced insulation)
- IP-20 protection through covers on the terminals

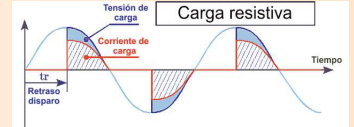

Standard models SO4 range

Code	Dimensions in mm	Output current	Output voltage	Control voltage	External supply
SO445020	45 x 58,5 x 27	50 A	180-280 Vac	0-10 Vdc	8-30 Vcc
SO465020		50 A	200-480 Vac	0-10 Vdc	8-30 Vcc
SO468020		95 A	200-480 Vac	0-10 Vdc	8-30 Vcc
SO469020		125 A	200-480 Vac	0-10 Vdc	8-30 Vcc
SO445120		50 A	180-280 Vac	0-5 Vdc	8-30 Vcc
SO468120		95 A	200-480 Vac	0-5 Vdc	8-30 Vcc
SO469120		125 A	200-480 Vac	0-5 Vdc	8-30 Vcc
SO445320		50 A	180-280 Vac	Potentiometer 10kΩ	8-30 Vcc
SO465320		50 A	200-480 Vac	Potentiometer 10kΩ	8-30 Vcc
SO445420		50 A	90-265 Vac	4...20 mA	Not require
SO465420		50 A	200-480 Vac	4...20 mA	Not require
SO467420		75 A	200-480 Vac	4...20 mA	Not require
SO468420	95 A	200-480 Vac	4...20 mA	Not require	
SO469420	125 A	200-480 Vac	4...20 mA	Not require	

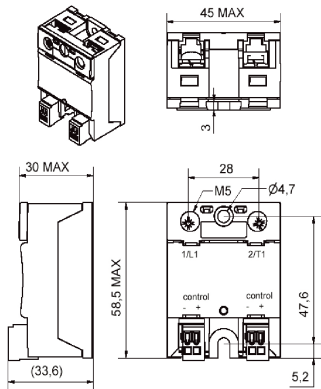

SGTA range, three-phase proportional controllers

Static relays with analogue input for power control for resistive loads through phase angle variation.

- Adaptable to three-phase resistive loads connected in star (or loads connected in delta on demand).
- Compact size.
- Broad frequency range (40-65Hz)
- Overvoltage protection.
- Three phase angle controllers fully opto-isolated (balanced currents, less harmonics,...)
- The minimum voltage applied to the load is the lowest on the market (3% RMS of nominal voltage compared to 40% RMS our competitors offer!)
- Multiple options possible on demand
- Manufactured in compliance with most international standards EMC, LVD, UL, VDE
- Usual applications: Temperature control of resistive loads (infrared lights, ceramic furnaces, heating elements, ...); lighting control of resistive loads (bulbs, halogen lights, scene lights ...)

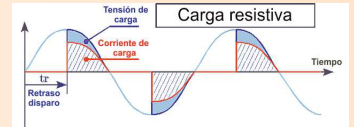

Standard models SGTA range

Code	Dimensions in mm	Output current	Output voltage	Control voltage	External supply
SGTA4650	75,15 x 100 x 46	50 A	300-510 Vac	0-10 Vdc	8-32 Vcc
SGTA4651		50 A	300-510 Vac	0-5 Vdc	8-32 Vcc
SGTA4653		50 A	300-510 Vac	Potentiometer 10kΩ	8-32 Vcc
SGTA4654		50 A	300-510 Vac	4...20 mA	8-32 Vcc

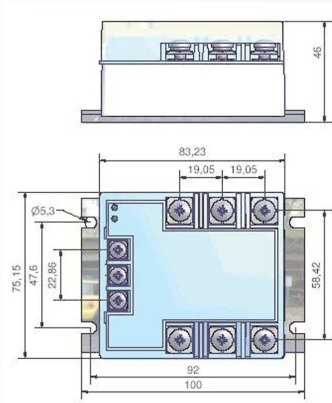

Internal diagram

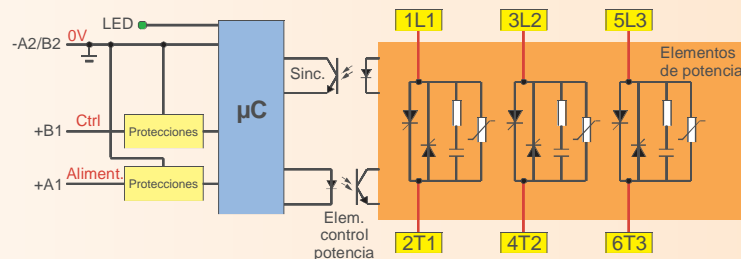



Configurable digital thyristor units, CD3000M model (1PH - 2 PH - 3PH)

The CD3000M models are digital and universal thyristor units that are configured through the serial communication port for calibration and power.

The CD3000M range includes thyristor units from: 1 phase up to 700 A; 2 phases for star or delta connection up to 700 A; 3 phases for star loads with neutral up to 500 A.

- Universal firing configurable by the user: Zero Crossing, ZC, 1-2-3 phases; Single cycle, SC, 1 phase; Burst firing, BF; Delayed triggering, DT; Phase angle, PA
- Universal input signal
- The Soft Start can be used for resistive loads in combination with phase angle and burst firing.
- Heater break alarm (HB) for load diagnosis or short circuit of the thyristors.
- Microprocessor electronic circuit fully isolated from the power.
- RS485 communication port. MODBUS protocol.
- IP-20 protection

Application guide	Load type	Model	Max current	N° of units	Suggested firing mode for your application						Sizing		Notes	
					ZC	SC	BF	S+BF	DT	PA	V	I		
	Normal Resistance Infraed Medium and long waveform	CD3000M-1PH	700 A	1		●	●				●	V	P/V	For general resistance applications with low variations in temperature and age. For low inertia loads use Single Cycle (SC) or Phase Angle (PA).
		CD3200	700 A	1							●			
	Noble metal, Tungsten, Superkarthol, Platinum Silicon carbide elements	CD3200	700 A	1							●	V	P/V	These resistances change with temperature but have low variations with age. Starting current with hold elements can be 16 times nominal current (superkanthal). Infraed lamp shot waveform can reach 8 time nominal current.
		CD3000M-1PH	700 A	1			●						V	P/V
	Transformers coupled with normal resistance	CD3000M-1PH	700 A	1						●		V	P/Vcosφ	Transformers and inductors have inrush current on start up. Phase Angle plus Soft Start and current limit are required. To switch the transformer ON-OFF, use DT firing that will automatically switch ON-OFF when current value is at zero.
		CD3200	700 A	1							●			
	Normal Resistance	CD3000M-2PH	700 A	2		●						V	P/V√3	CD3000M-2PH is suitable to control resistive loads with delta or star connection without neutral.
	Normal Resistance	CD3000M-3PH	500 A	3		●						V/√3	P/V√3	Three phase load with star plus neutral connection must be controlled in the three phases.
	Three phase normal load resistance with open delta connection	CD3000M-3PH	500 A	3		●						V	P/3V	Open delta can be driven by three phase unit or three on phase unit.



Firing modes

A correct choice of firing mode enables the thyristor unit to be optimised for the load installed.

The thyristor unit comes already configured according to the customer's requirements defined in the order code. However, if you need to change the kind of firing you can do so by changing the parameters or the configuration software through the serial communication port.

1.- ZC - Zero crossing

The ZC mode is used with the logic output of the temperature controllers and the thyristor operates like a contactor.

The cycle time is executed through the temperature controller. The ZC firing mode minimizes interferences as the thyristor unit switches ON/OFF at zero crossing volts.

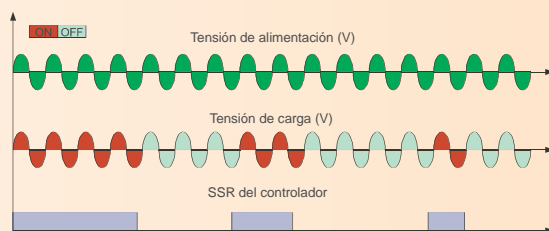

2.- SC - Single cycle

The SC firing mode is the fastest zero crossing switch in relation to the power demand made by the temperature controller or another external signal.

- With input signal at 25% the output is 1 cycle ON and 3 cycles OFF.
- With input signal at 50% the output is 1 cycle ON and 1 cycle OFF.
- With input signal at 75% the output is 3 cycles ON and 1 cycle OFF.
- With input signal at 76% the output is the same as at 75%, but for each cycle ON the microprocessor divides 76/75, and when the sum of the rest is one, the unit has an extra cycle in ON. For this kind of firing the input must be analogue.

The single cycle is used to control low inertia loads or short wave infrared lamps.

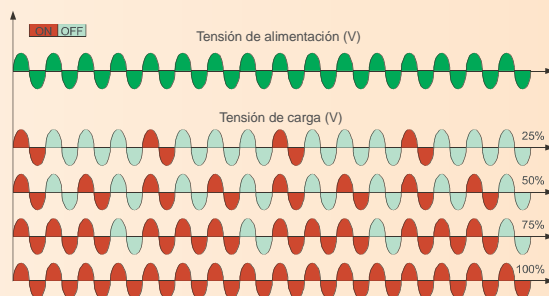

3.- BF - Burst firing

The BF firing mode is similar to the single cycle, but the number of consecutive cycles can be selected between 2 and 255, with the input signal at 50%.

The BF mode is a zero crossing mode that reduces electromagnetic interferences as the thyristor changes to zero crossing volts.

The example shows the BF with burst cycles = 4 (P126L=4)

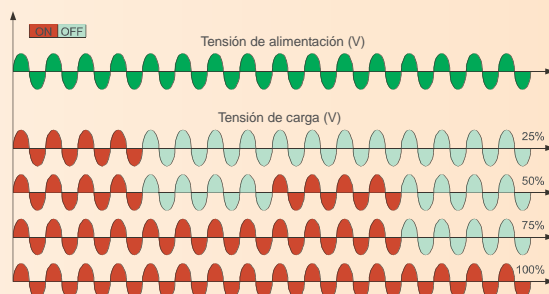

4.- S+BF - Soft start + Burst firing

This is an additional function to that of BF. The unit starts in phase angle mode with a ramp that goes from 0 to 100% of the voltage in the time set in the P125H parameter.

When the ramp finishes, the thyristor remains ON at full voltage until the burst cycles have finished. The mode S + BF is used to control small inductive loads in order to avoid input peak currents and to reduce electromagnetic interferences.

The example shows the firing with the burst cycles = 4 and the ramp time = 60 msec at 50 Hz. (P126L = 4 / P125H = 12)

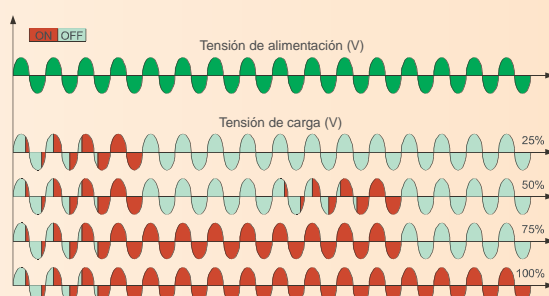

5.- PA - Phase angle

The PA mode enables the power on the load to be monitored. For this firing the thyristor can only be in conduction for a part of the load voltage cycle.

This part of the load voltage cycle can be adjusted according to the input signal from 0 to 100%.

The PA firing is usually used for monitoring inductive loads. The only disadvantage with the PA mode is the possibility of interferences, which, however, can be reduced by using filters.

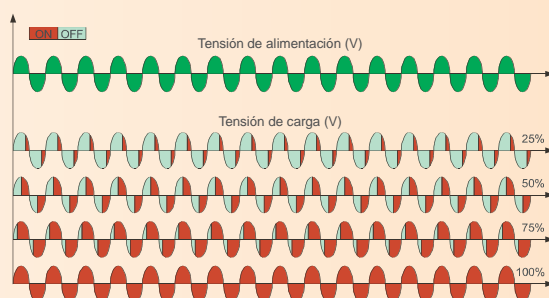

6.- DT - Delay triggering

The DT mode is used to control a transformer's primary, along with the normal heating element in the secondary (Note: Do not connect in the secondary cold heating elements type Superkanthal, Molybdenum, Platinum, Tungsten, quartz lamps).

For an inductive load (e.g. transformer), the switching of the thyristors to zero crossing can generate temporary over-intensities that may blow the fuses. To prevent this, delay triggering should be used. This firing mode delays the first half of the burst cycle.

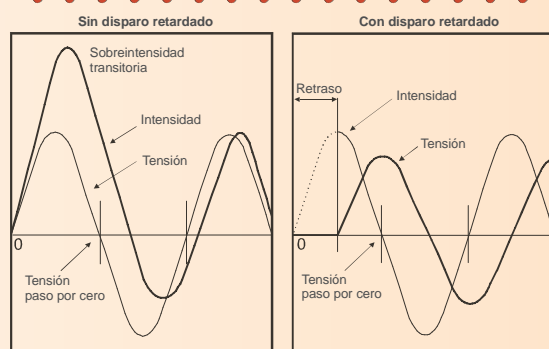



1 phase configurable universal thyristor, CD3000M-1PH model

Technical features

- Working temperature: 0/40 °C for models up to 110 A. For higher temperatures see the degradation curve.
- Supply voltage: 24 V minimum, 440 V maximum. 600 V on demand.
- Universal input signal: SSR, 4...20 mA, 0-10 V, potentiometer 10 K, configurable by user with automatic circuit calibration.
- Universal firing: one of these triggers can be configured through the serial port: zero crossing (ZC), burst firing (BF), single cycle (SC), soft start + burst firing (S + BF), delay triggering (DT), phase angle (PA), soft start + phase angle (S+PA)
- Auxiliary supply voltage: 240 V or 440 V ±15%, 10 VA
- Ventilator supply: 240 V ± 15%
- Heater alarm break: Discrimination over 20%. Microprocessor circuit based on the total or partial diagnosis of the load failure or short circuit in the thyristor. Alarm blocking + reset. Relay output 1 A - 240V
- Heater alarm break: Discrimination over 20%. Microprocessor circuit based on the total or partial diagnosis of the load failure or short circuit in the thyristor. Alarm blocking + reset. Relay output 1 A - 240V
- Assembly: DIN rail assembly for models up to 45 A, on plate from 45 A.
- IP-20 protection.

Encoding mode

Model	Current (A)	Op. voltage		Aux. voltage	Input	Firing mode	Feedback	Options
		min	max					
CD3200	15	24 V	480 V	230 V	0-10 V	S+PA (Soft start + Phase angle)	V	NCL (No current limit)
	25		600 V	460 V	4...20 mA	PA (Phase angle)	I	COMM (RS485 MODBUS)
	35			600 V	10 K Pot.		V ²	CD-KP (External Key pad)
	45							EF (External fuse + Fuse holder until 110A)
	60							NF (No fuse)
	90							IF (Internal fuses are standard over 110A)
	110							HB (Heater break alarm)
	125							110V FAN (Fan at 110 V)
	150							UL (cUL us Listed)
	200							
	300							
	400							
	500							
	600							
	700							

Example code

CD3200 /	125A /	440V /	480V /	460V /	0-10V /	PA /	V ² /	UL
----------	--------	--------	--------	--------	---------	------	------------------	----

Dimensions in mm

CD3200
15-25A



CD3200
35-45A



CD3200
60-90A



CD3200
110A



CD3200
125-200A



CD3200
300-700A

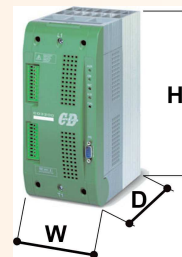

	W	H	D
15 A	63	120	120
25 A	63	120	120
35 A	85	120	120
45 A	85	120	120

	W	H	D
60 A	148	120	159
90 A	148	120	159
110 A	148	138	159
125 A	116	316	187

	W	H	D
150 A	116	316	187
200 A	116	316	187
300 A	137	520	270
400 A	137	520	270

	W	H	D
500 A	137	520	270
600 A	137	520	270
700 A	137	520	270

Fuses and fuse holders

- External fuse + fuse holder for models up to 110A
- Internal fuse for models from 125A to 700A





Tyristor universal configurable 1 fase, modelo CD3000M-1PH

Technical features

- Working temperature: 0/40 °C for models up to 100 A. For higher temperatures see the degradation curve.
- Supply voltage: 24 V minimum, 440 V maximum. 600 V on demand.
- Universal input signal: SSR, 4...20 mA, 0-10 V, potentiometer 10 K, configurable by user with automatic cycle calibration.
- Universal firing: one of these firings can be configured through the serial port: zero crossing (ZC), burst firing (BF)
- Auxiliary supply voltage: 230 V ó 460 V ±15%, 10 VA
- Ventilator input: 230 V ± 15%
- Heater break alarm: discrimination above 20%. Circuit to microprocessor based on the total or partial diagnosis of the load failure or short circuit in the thyristor. Alarm blocking + reset. Relay output 1A - 230V
- Online voltage drop: Automatic compensation ± 15% of the supply voltage with analogue input.
- Assembly: DIN rail assembly for models up to 100A, on plate from 100A.
- IP-20 protection.

Encoding mode

Model	Current (A)	Op. voltage		Aux voltage	Input	Firing mode	Options
		min	max				
CD3000M-1PH	15	24 V	480 V	230 V	SSR	ZC (Zero Crossing)	COMM (RS485 MODBUS)
	25		600 V	460 V	0-10 V	SC (Single Cycle)	CD-KP (External Key pad)
	35			600 V	4...20 mA	BF (Burst Firing)	EF (External fuse + Fuse holder until 110A)
	45				10K Pot.	DT (Delayed Trigg. + Burst F.)	NF (No fuse)
	60					S+BF (Soft Start + Burst F.)	IF (Internal fuses are standard over 110A)
	90					PA (Phase Angle)	HB (Heater break alarm)
	110						110V FAN (Fan at 110 V)
	125						UL (cULus Listed)
	150						
	200						
	300						
	400						
	500						
	600						
	700						

Note: for Burst Firing specify the desired n° of cycles ON at 50% of power demand

Example code

CD3000M-1PH /	150A /	440V /	480V /	460V /	4...20mA /	PA /	HB
---------------	--------	--------	--------	--------	------------	------	----

Dimensions in mm

CD3000M-1PH
15-25A



	W	H	D
15 A	63	120	120
25 A	63	120	120
35 A	85	120	120
45 A	85	120	120

CD3000M-1PH
35-45A



	W	H	D
60 A	148	120	159
90 A	148	120	159
110 A	148	138	159
125 A	116	316	187

CD3000M-1PH
60-90A



CD3000M-1PH
110A



	W	H	D
150 A	116	316	187
200 A	116	316	187
300 A	137	520	270
400 A	137	520	270

CD3000M-1PH
125-200A

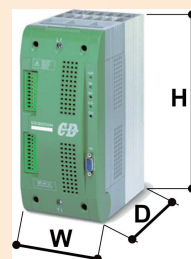

	W	H	D
500 A	137	520	270
600 A	137	520	270
700 A	137	520	270

CD3000M-1PH
300-700A



Fuses and fuse holders

- External fuse + fuse holder for models up to 100A
- Internal fuse for models from 125A to 700A





Universal 2 phase configurable thyristor, CD3000M-2PH model

Technical features

- Working temperature: 0/40 °C for models up to 90 A. For higher temperatures see the degradation curve.
- Supply voltage: 24 V minimum, 440 V maximum. 600 V on demand.
- Universal input signal: SSR, 4...20 mA, 0-10 V, potentiometer 10 K, configurable by user with automatic cycle calibration.
- Universal firing: One of these firings can be configured through the serial port: zero crossing (ZC), burst firing (BF)
- Auxiliary supply voltage: 230 V or 460 V ±15%, 10 VA
- Ventilator supply 230 V ± 15%
- Heater break alarm: Discrimination over 20%. Circuit at microprocessor based on the total or partial diagnosis of the load failure or short circuit in the thyristor. Alarm blocking + reset. Relay output 1A - 230V
- Online voltage drop: automatic compensation ± 15% of the supply voltage with analogue input.
- Assembly: DIN rail assembly for models up to 90A, on plate from 90A.
- IP-20 protection.

Modo de codificación

Model	Current (A)	Op. voltage		Aux. voltage	Input	Firing mode	Options
		min	max				
CD3000M-2PH	15	24 V	480 V	230 V	SSR	ZC (Zero Crossing)	COMM (RS485 MODBUS)
	25		600 V	460 V	0-10 V	BF (Burst Firing)	CD-KP (External Key pad)
	35			600 V	4...20 mA		EF (External fuse + Fuse holder until 110A)
	45				10 K Pot.		NF (No fuse)
	75						IF (Internal fuses are standard over 110A)
	100						HB (Heater break alarm)
	125						110V FAN (Fan at 110 V)
	150						UL (cUL us Listed)
	200						
	275						
	400						
	450						
	500						
	600						
	700						

Note: for Burst Firing specify the desired n° of cycles ON at 50% of power demand

Example code

CD3000M-2PH /	150A /	440V /	480V /	460V /	4...20mA /	ZC /	HB
---------------	--------	--------	--------	--------	------------	------	----

Dimensiones en mm

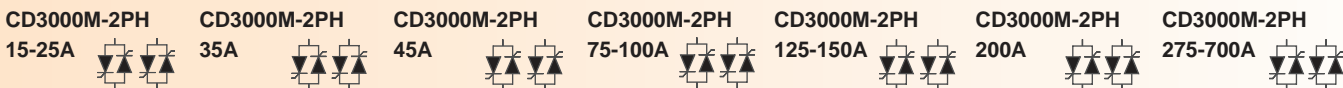

	W	H	D
15 A	123	145	120
30 A	148	120	123
45 A	148	138	123
60 A	148	138	159

	W	H	D
75 A	148	138	159
90 A	148	138	159
125 A	137	440	270
150 A	137	440	270

	W	H	D
225 A	262	440	270
300 A	262	520	270
350 A	262	520	270
400 A	262	520	270

	W	H	D
450 A	262	520	270
500 A	262	520	270

Fusibles y portafusibles

- Fusible externo + portafusibles para modelos hasta 100A
- Fusible interno para modelos desde 125A a 700A





Universal 3 phase configurable thyristor, CD3000M-3PH model

Technical features

- Working temperature: 0/40 °C for models up to 90 A. For higher temperatures see the degradation curve
- Supply voltage: 24 V minimum, 440 V maximum. 600 V on demand.
- Universal input signal: SSR, 4...20 mA, 0-10 V, potentiometer 10 K, configurable by user with automatic cycle calibration.
- Universal firing: One of these firings can be configured through the serial port: zero crossing (ZC), burst firing (BF)
- Auxiliary supply voltage: 230 V or 460 V ±15%, 10 VA
- Ventilator supply 230 V ± 15%
- Heater break alarm: Discrimination over 20%. Circuit at microprocessor based on the total or partial diagnosis of the load failure or short circuit in the thyristor. Alarm blocking + reset. Relay output 1A - 230V
- voltage drop: automatic compensation ± 15% of the supply voltage with analogue input.voltage drop: automatic compensation ± 15% of the supply voltage with analogue input.
- Assembly: DIN rail assembly for models up to 90A, on plate from 90A.
- IP-20 protection.

Encoding mode

Model	Current (A)	Op. voltage		Aux. voltage	Input	Firing mode	Options
		min	max				
CD3000M-3PH	15	24 V	480 V	230 V	SSR	ZC (Zero Crossing)	COMM (RS485 MODBUS)
	30		600 V	460 V	0-10 V	BF (Burst Firing)	CD-KP (External Key pad)
	45			600 V	4...20 mA	Note: for Burst Firing specify the desired n° of cycles ON at 50% of power demand	EF (External fuse + Fuse holder until 110A)
	60				10K Pot.		NF (No fuse)
	75						IF (Internal fuses are standard over 110A)
	90						HB (Heater break alarm)
	125						110V FAN (Fan at 110 V)
	150						UL (cULus Listed)
	225						
	300						
	350						
	400						
	450						
	500						

Example code

CD3000M-3PH /	150A /	440V /	480V /	460V /	4...20mA /	ZC /	HB
---------------	--------	--------	--------	--------	------------	------	----

Dimensions in mm

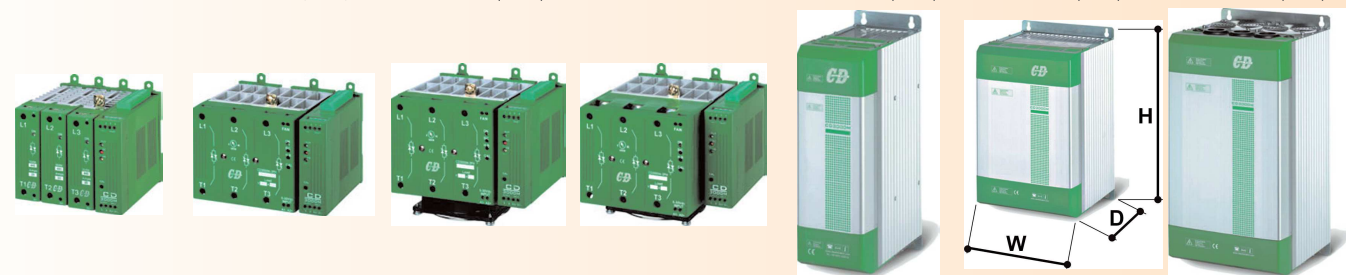
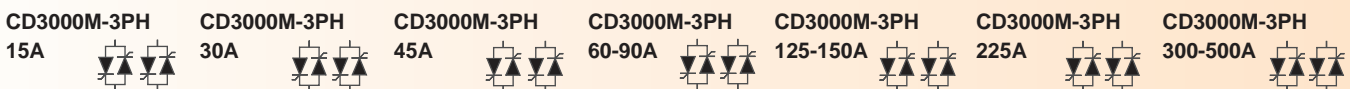

	W	H	D
15 A	123	145	120
30 A	148	120	123
45 A	148	138	123
60 A	148	138	159

	W	H	D
75 A	148	138	159
90 A	148	138	159
125 A	137	440	270
150 A	137	440	270

	W	H	D
225 A	262	440	270
300 A	262	520	270
350 A	262	520	270
400 A	262	520	270

	W	H	D
450 A	262	520	270
500 A	262	520	270

Fuses and fuse holders

- External fuse + fuse holder for models up to 90A
- Internal fuse for models from 125A to 500A





Safety valves for steam, gases and liquids.

If a fluids system is subjected to pressure higher than its design, the following could occur:

- Mechanical damages to the equipment and surrounding area.
- Loss of product and production.
- Environmental damage.
- Personal injury.

Examples of circumstances that may cause excess pressure surges in process applications include an inadvertently closed or open valve, a component breakdown, a failure in the cooling system, an abnormal input of heat in the process, a short circuit or fire.

Modern companies are obliged by health and safety standards to make sure their plants and processes include safety devices and that they take the appropriate precautions to avoid hazardous conditions.

However, where there might be a pressure surge situation a safety valve is required. The safety valve protects from pressure surges through a broad spectrum of industrial processes.

Systems that require protection against excess pressure vary in size and complexity from large chemical plants to distribution, service or commercial systems.

- API 527 watertight locking
- Appropriate for saturated, clean or superheated steam, air or inert gases.
- Safety valves up to DN300 and 400 pressure bar with a wide range of materials, conditions and options.
- Couplings with thread or flange ASME or DIN



Advantages for the user

- A safe working environment and continuous efficient production.
- Appropriate for pressure relief applications all around the world.
- Valid for a wide range of fluids.
- Comprehensive solution appropriate for applications throughout the process plant.
- Guarantee of quality and reliability.
- Proven reliability minimising inactivity time and maintenance costs.
- Safety valves when and where required.

Testing and development facilities

Our own dynamic testing facility uses cutting-edge software for fast data capture to log and assess the operating characteristics of each valve under development.

Performance tests can be performed in steam, air and water with a maximum pressure capacity of 45 bar.

Mechanical assembly, configuration and dispatch

All our products are manufactured according to ISO 9001. Most valves are designed and developed in-house and you can benefit from the most important and continuous investments we make, starting with the design outlines drawn up with CAD 3D system, going on to the mechanical components manufacturing in our own mechanising centres that have the latest technology in machine-tool and finally to the point where our qualified staff assemble and configure each valve before sending them to the customer.

Delivery speed is of utmost importance and many of our standard products are available in stock.

Measurements and selection

We can supply the correct valve for most pressure relief applications and we have a complete library of technical support that covers the most common fluids. Help is always available for any sizes or for selection and we have software to ensure fast measurement of the valve along with the datasheet.



library of technical support that covers the most common fluids. Help is always available for any sizes or for selection and we have software to ensure fast measurement of the valve along with the datasheet.

Valve dimensions

Maximum flow calculation

This value should be the maximum flow there may be in the system, for example, the maximum load of a boiler or the maximum capacity of the valve.

Calculating tare pressure

The tare pressure should be sufficiently low to ensure that it does not exceed the maximum accumulation pressure permitted in the boiler or system it should be protecting.

The tare pressure should be sufficiently high to ensure there is a sufficient margin above to ensure correct system operating and that the valve can be closed. However, it can never exceed the system's maximum working pressure permitted. For safety valves installed downstream in pressure reducing stations it is essential to establish the pressure without load, as this is significantly higher than the working pressure in a direct action valve.

Correct sizing of the safety valve

When the type of safety valve has been selected and the flow and tare pressure established, the correct valve size can be determined. For fluids like steam, air and water, it is usually enough to use the capacity tables published to correctly size the safety valve. That is, one whose capacity slightly exceeds the excess pressure. When there are no capacity tables or the specific fluid or conditions are not taken into consideration, then the effective area required should be calculated and a larger effective area selected.

For hot water applications where there might be re-steaming, the capacity tables are not appropriate as a percentage of the unloading will be steam and this should be taken into account when calculating the size.

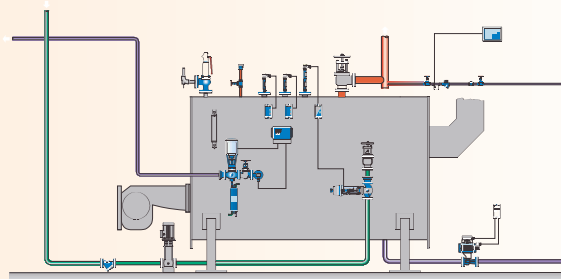

Typical application



The range of spring-loaded safety valves with SV60 full opening has been designed to protect against excess pressure during a broad spectrum of industrial processes. Appropriate for use with steam, gases and liquids, the SV60 safety valves provide a comprehensive and competitive solution to most applications, including protection of boilers, lines and pressure containers, compressors and receptors, and for most process applications.

The safety valves are of simple design and available with input sizes DN20 to DN150 and are appropriate for pressures up to 40 bar.

The safety valves protect staff, the plant and profit and therefore quality should not be compromised when selecting a valve.

The SV60 range of safety valves complies with the strict standard established by ADMerkblatt A2 and TRD 421. Their performance has been tested and approved by TÜV.

The hermetic seal quality is a critical feature of any safety valve and each is tested to make sure the seal complies with the requirements of standard API 527 of the

American Petrochemical Institute.

- Stock availability
- Compact design for large flows
- Wide range of materials for the body, lid and with lever or closed cover means they can be adapted to most applications' requirements.
- Watertight seal API 527



Technical data

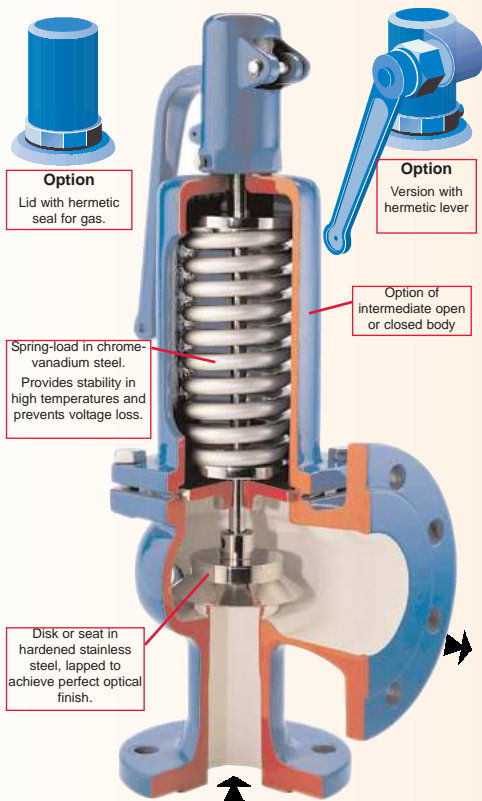

Model	SV604		SV607	
Valve size	DN20 - 150		DN20 - 150	DN65 - 100
Connections	Inlet	PN40 or ANSI 300	PN25	PN16
	Outlet	PN16 or ANSI 150	PN16	
Materials	Body	Carbon steel	SG iron	
	Bonnet	GSC 25	GGG 40.3	
	Cap	Carbon steel	SG iron	
		GSC 25	GGG 40.3	
	Seat	Stainless Steel 1.4057	Acero inoxidable 1.4057	
	Disc	Stainless Steel hardened 1.4021	Stainless Steel hardened 1.4021	
	Spring	Standard Temp. > 230 °C	Chrome-Vanadium alloy steel	Chrome-Vanadium alloy steel
Limiting conditions	Body design	PN40	PN25	PN16
	Set pressure range	0,2 to 40 bar	0,2 to 25 bar	0,2 to 16 bar
	Temperature range	-10 °C to +400 °C (*)	-10 °C to +350 °C (*)	

(*) Note: For temperatures over 230 °C the spring load must be tungsten steel alloy.

Dimensions in mm and weight in Kg

Connections		A	B	C	ØD	Weight
Inlet	Outlet					
DN20	DN32	85	95	385	17,1	10
DN25	DN40	100	105	435	23,8	12
DN32	DN50	110	115	450	30,7	15
DN40	DN65	115	140	520	38,1	17
DN50	DN80	120	150	535	50,2	20
DN65	DN100	140	170	710	59,0	38
DN80	DN125	160	195	790	73,0	50
DN100	DN150	180	220	835	91,0	77
DN125	DN200	200	250	1042	105,0	115
DN150	DN250	225	285	1165	125,0	180

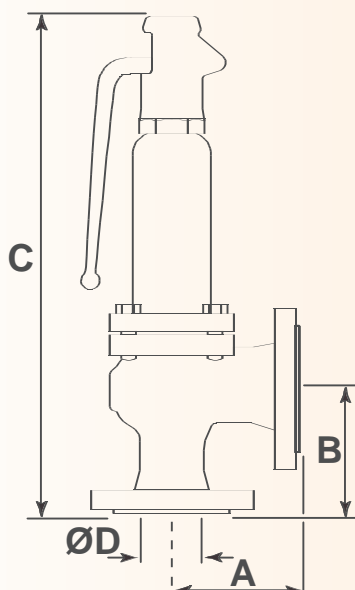

SV60 valve selection guide

Model	SV60			
Body material	4	Steel		
	7	SG iron		
Configuration	A	Closed bonnet / easing lever		
	B	Closed bonnet / gas tight cap		
	C	Closed bonnet / packed easing lever		
	D	Open bonnet / easing lever		
Seal material	S	Stainless steel with chrome-vanadium spring		
Selection example	SV60	7	A	S

How to place an order:

Example: 1 safety valve model SV607AS with DN50 input DN80 output PN16 calibrated to 6 Bar



The SV615 range of spring-loaded safety valves with full opening has been designed to protect against excess pressure for a wide range of industrial processes. Appropriate for use with steam, air and water, the SV615 safety valves provide a comprehensive and competitive solution for most applications, including protection of steam or hot water boilers, pressure containers, compressors or receptors, autoclaves, pressure reducing stations and for most process applications.

The safety valves are of simple design and available with input sizes DN15 to DN50. All the valves have a closed intermediate body with or without a lever, with optional seats in nitrile, EPDM or Viton. The safety valves protect staff, the plant and profit, so quality cannot be compromised when selecting a valve.

The SV615 range of safety valves are officially approved by **SAFed TAS** (Royal and Sun Alliance) and comply with the standards established by **BS6759 part 1, 2 and 3** and with the **European Pressure Equipment Directive EC 97/23**.

The quality of the hermetic seal is a critical feature of any safety valve and each one is tested to ensure the seal complies with the requirements of standard **API 527** of the American **Petrochemical Institute**.

- Stock availability
- Compact full opening design for large flows.
- Options of soft seat and no lever.
- API 527 watertight seal



Technical data

Valve size	Inlet	Screwed BSP (BS 21 parallel) or NPT Sanitary clamp (DN15 to DN25 sizes only) BS 4825 / ISO 2852 / DIN 32676	
	Outlet	Screwed BSP (BS 21 parallel) or NPT	
Materials	Body	Bronze	BS EN 1982 CC491K
	Nozzle	Standard	Stainless steel BS 3146 Pt2 Gr. ANC2
		Sanitary clamp	Stainless steel ASTM A276 316L
	Asiento blando	Nitrile	
		EPDM	
		Viton	
Disc	Standard	Stainless steel	BS 970 431 S29
	Sanitary clamp	Stainless steel	ASTM A276 316L
Spring	Chrome-Vanadium alloy steel		BS 2803 730 A65
Limiting conditions	Cond. diseño cuerpo	PN25	
	Set pressure range	1/2" a 1 1/2"	0.3 bar up to 18 bar
		1 1/2" y 2"	0.3 bar up to 14 bar
	Test pressure	37,5 bar	
	Temperature range	Stainless steel seat	-90 °C to +230 °C
	Soft seal material	Soft seal material	Nitrile
		EPDM	-50 °C to +150 °C
		Viton	-20 °C to +200 °C

Dimensions in mm and weight in Kg

Type of connection	Size	Connection		A	B	C	ØD	Weight
		Inlet	Outlet					
Screwed	DN15	1/2"	3/4"	40	40	194	12	1,3
	DN20	3/4"	1 1/4"	55	44	229	20	2,4
	DN25	1"	1 1/2"	60	48	242	24	2,9
	DN32	1 1/4"	2"	70	58	279	29	4,2
	DN40	1 1/2"	2 1/2"	81	67	365	37	8,8
Sanitary clamp	DN15	1/2"	3/4"	40	55	209	12	1,4
	DN20	1"	1 1/4"	55	60	245	20	2,6
	DN25	1"	1 1/2"	60	64	258	24	3,1

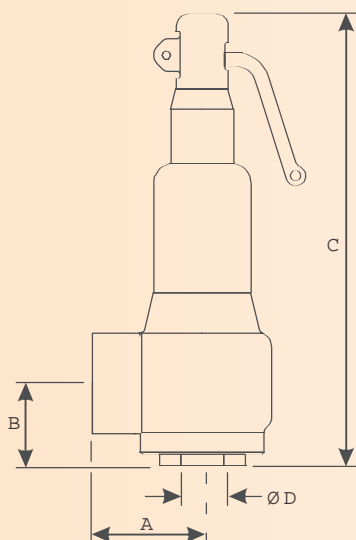
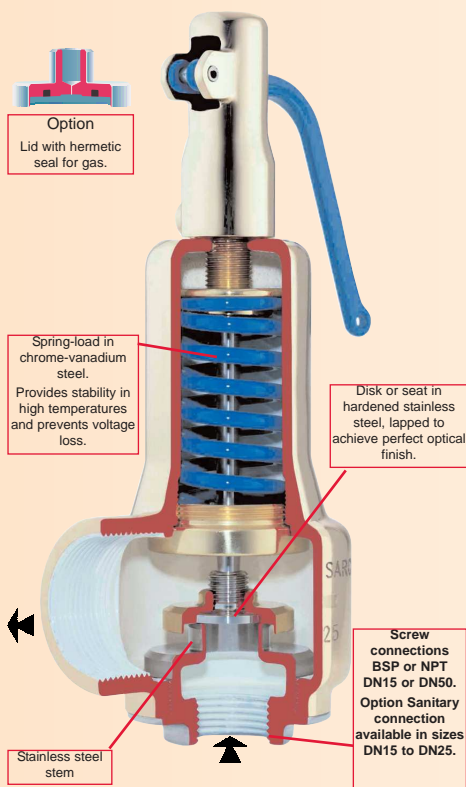

SV60 valve selection guide

Model	SV60				
Configuration	A	Closed bonnet / easing lever			
	B	Closed bonnet / gas tight cap			
Seal material	S	Stainless steel with chrome-vanadium spring			
	N	Nitrile			
	E	EPDM			
	V	Viton			
Size	DN15 – DN20 – DN25 – DN32 – DN40 – DN50				
Connection	BSP – NPT – Sanitary clamp (DN 15 to DN25 sizes only)				
Selection example	SV615	A	N	DN15	BSP

How to place an order:

Example: 1 safety valve model SV615AN with DN15 thread BSP (input 1/2" -output 3/4") calibrated to 3 bar.





SV-6205 safety valve

General features

- Brass body and cover
- Soft seat gasket with FPM seal.
- Unducted outlet.
- Input: male thread type G (BSP) as per ISO 228/1
- Working temperatures: -20 °C up to +160 °C
- Official approval TÜV-SV.1090.D/G
- Standard marking according to the Directive of Pressure Equipment 97/23/EC
- Special options on demand only:
 - Stainless steel spring-load, DIN EN 1.4571 material (AISI 316Ti)
 - Nickel-plated external parts

Applications

Designed as a safety device to protect from excess pressure in pressure containers. Appropriate for use with air and similar gases.

Code	Nominal Size GW	Set pressure range (bar)	Dimensions in mm				Weight Kg
			Orifice d ₀	H	L2	Wrench size across flats S1	
SV6205-0200	¼"	0,4 – 35	7	60	10	21	0,07
SV6205-0300	⅜"	0,4 – 35	7	60	10	21	0,07
SV6205-0704	½"	0,4 – 35	7	67	12	24	0,17
SV6205-0400	½"	0,2 – 22	12	78	12	27	0,17
SV6205-0600	¾"	0,2 – 16	15	92	15	32	0,27
SV6205-1000	1"	0,2 – 18	18	110	18	41	0,48
SV6205-1200	1 ¼"	0,2 - 16	20	125	20	48	0,75

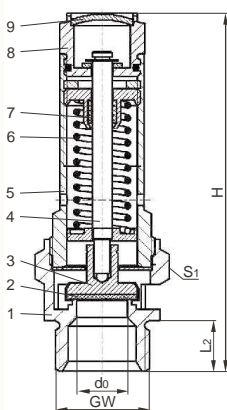

Materials	DIN EN	ASTM
1 Body	CW614N	B 283 UNS C38500
2 Valve seal	FPM (Vitón)	
3 Disc	CW614N	B 283 UNS C38500
4 Stem	CW614N	B 283 UNS C38500
5 Bonnet	CW614N	B 283 UNS C38500
6 Spring	1.1200	A 576 Gr. 1045
7 Stem guide	PTFE	
8 Lifting device	CW614N	B 283 UNS C38500
9 Closing cap	CW507L	B 30 UNS C26800

Attention: The valves are supplied calibrated so when you place your order please confirm the tare pressure, fluid and temperature. Appropriate for use with air and similar gases.



SV-6217 safety valve

General features

- Brass body and cover
- Soft seat gasket with FPM seal
- Unducted outlet
- Input: male thread type G (BSP) as per ISO 228/1
- Working temperatures -25 °C up to +200 °C
- Official approval TÜV-SV.1091.D/G
- Standard marking according to Directive for Pressure Equipment 97/23/EC (PED)
- Special options on demand only:
 - Discharge outlets with protection cover.
 - Stainless steel spring-load, material DIN EN 1.4571 (AISI 316Ti)
 - Nickel-plated external parts

Applications

Designed as a safety device to protect from excess pressure in pressure containers. Appropriate for use with air and similar gases.

Code	Nominal Size GW	Set pressure range (bar)	Dimensions in mm				Weight Kg
			Orifice d ₀	H	L2	Wrench size across flats S1	
SV6217-1400	1 ½"	0,2 – 16	32	202	22	55	1,73
SV6217-2000	2"	0,2 - 12	40	230	25	70	3,09

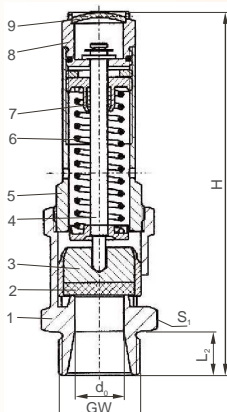

Materials	DIN EN	ASME Code Case 1750-20
1 Body	CW617N	EN 12165
2 Valve seal	FPM (Vitón)	
3 Disc	CW614N	EN 12164
4 Stem	CW614N	EN 12164
5 Bonnet	CW614N	EN 12164
6 Spring	1.1200	A 576 Gr. 1045
7 Stem guide	PTFE	
8 Lifting device	CW614N	EN 12164
9 Closing cap	CW507L	B 30 UNS C26800

Attention: The valves are supplied calibrated so when you place your order please confirm the tare pressure, fluid and temperature. Appropriate for use with air and similar gases.



SV-6370 safety valve

General features

- Body and cover in brass/bronze
- Elastomers seal
- With diaphragm for spring protection
- Input/output: female thread type G (BSP) as per ISO 228/1
- Working temperatures: -10 °C up to +110 °C
- Official approval TÜV-SV.749.F

- Standard marking as per the Directive for Pressure Equipment 97/23/EC (PED)
- Special options on demand only:
 - Spring-load in stainless steel, material DIN EN 1.4571 (AISI 316Ti)
 - Nickel-plated external parts

Applications

Designed as a safety device to protect against excess pressure in pressure containers.
Appropriate for use with non-toxic and non-flammable liquids that do not vaporise during discharge.

Code	Nominal Size GW - GA	Set pressure range (bar)	Dimensions in mm				Wrench size across flats S1	Weight Kg
			Orifice d ₀	H	L1	L2		
SV6370-0400	½"	1,0 – 16	12	92	25	20	27	0,24
SV6370-0600	¾"	1,0 – 16	15	111	30	25	32	0,40
SV6370-1000	1"	1,0 – 16	18	132	36	30	41	0,70
SV6370-1200	1 ¼"	1,0 – 16	20	152	40	35	50	1,07
SV6370-1400	1 ½"	1,0 – 16	24	175	48	40	58	1,65
SV6370-2000	2"	1,0 – 16	28	200	56	48	70	2,65

	Materials	DIN EN	ASTM
1	Body	CC491K	B 62 UNS C83600
2	Disc nut	CW612N	B 283 UNS C37700
3	Plate	CW507L	B 30 UNS C26800
4	Valve seal	NBR / PTFE / FPM	
5	Disc	CW612N	B 283 UNS C37700
6	Diaphragm	NBR	
7	Stem	CW612N	B 283 UNS C37700
8	Bonnet	CW612N	B 283 UNS C37700
9	Spring	1.1200	A 576 Gr. 1045
10	Lifting device	CW612N	B 283 UNS C37700
11	Closing cap	CW507L	B 30 UNS C26800

Attention: The valves are supplied calibrated so when you place your order please confirm the tare pressure, fluid and temperature.

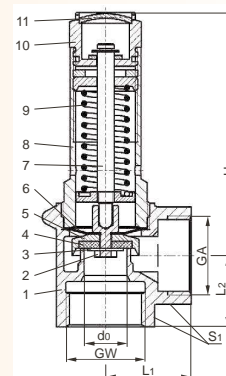

SV-6395 safety valve

General features

- Body and cover in brass/bronze
- Metal / metal seal
- Input/output: female thread type G (BSP) as per ISO 228/1
- Working temperatures: -10 °C up to +225 °C
- Official approval TÜV-SV.910.D/G

- Standard marking as per Directive for Pressure Equipment 97/23/EC (PED)
- Special options on demand only:
 - Stainless steel spring-load, material DIN EN 1.4571 (AISI 316Ti)
 - Nickel-plated external parts

Applications

Designed as a safety device to protect against excess pressure in pressure containers and steam boilers.

Code	Nominal size inlet GW	Nominal size outlet GA	Set pressure range (bar)	Dimensions in mm				Wrench size across flats S1		Weight Kg
				Orifice d ₀	H	L1	L2	S1	S2	
								S1	S2	
SV6395-0400	½"	1	0,5 - 25	15	144	36	41	32	41	0,75
SV6395-0600	¾"	1 ¼"	0,5 - 25	18	166	50	48	41	50	1,25
SV6395-1000	1"	1 ½"	0,5 - 25	23	195	48	58	50	58	1,85
SV6395-1200	1 ¼"	2"	0,5 - 12	28	222	58	68	55	70	3,0

	Materials	DIN EN	ASTM
1	Body	CC491K	B 62 UNS C83600
2	Inletbody	CW509L	B 111 UNS C28000
3	Valve seal		
4	Disc metal seated	1.4541	A 276 Gr. 321
4a	Disc soft seated	CW612N	B 283 UNS C37700
5	Stem	CW612N	B 283 UNS C37700
6	Bonnet	CW612N	B 283 UNS C37700
7	Spring	1.4571	A 276 Gr. 316Ti
8	Lifting device	CW612N	B 283 UNS C37700
9	Closing cap	CW507L	B 30 UNS C26800

Attention: The valves are supplied calibrated so when you place your order please confirm the tare pressure, fluid and temperature.

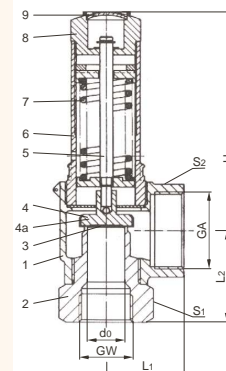
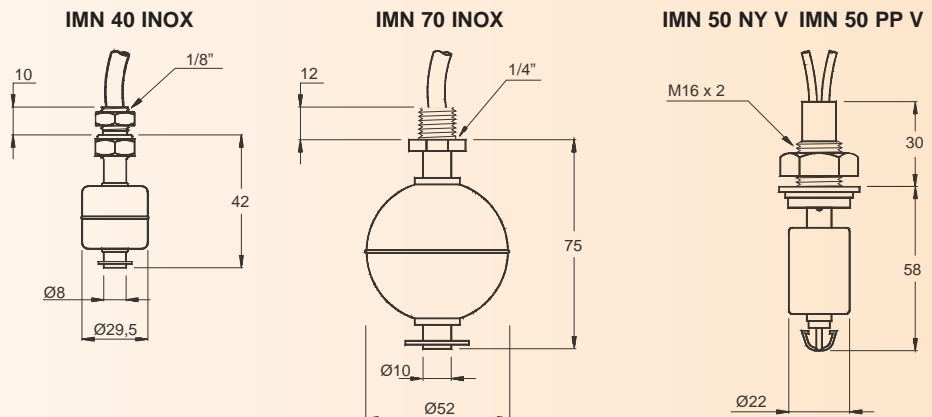



Table of chemical resistance to Stainless Steel AISI 316 (*)			
Product	Temperature °C		
	20	60	100
Mineral oils	+	+	+
Acetic acid 10-50%	+	+	+
Boric acid	+	+	+
Chromic acid 10%	+	+	•
Nitric acid 0-50%	+	+	+
Nitric acid 95-98%	+		•
Hydrogen peroxide 60%	+	+	+
Ammoniac liquid	+	+	+
Benzene	+	+	+
Glicol	+	+	+
Trichloroethylene	+		

SIGNALS			
Unaltered	+	Do not resist	•

NOTE: The data contained in the tables are understood to be without commitment and can be altered by factors like pressure, concentration etc.



MAGNETIC LEVEL SWITCHES. GENERAL CHARACTERISTICS. STANDARD MODELS

	IMN 40 INOX	IMN 70 INOX	IMN 50 NY V	IMN 50 PP V
ATTACHMENT	1/8" BSP connector	1/4" BSP connector	M 16 x 2 connector	
BODY MATERIAL	Stainless steel AISI 316			
FLOAT MATERIAL	Stainless steel AISI 316			
CONNECTION	Silicone cable 130 °C - PVC 90 °C 1 m Long		PVC Cable 0,5 m long	
CONTACT TYPE	NO or NC according to float position			
MAXIMUM CUTOUT CAPACITY	40 W/VA	80 W/VA	15 W/VA	
MAXIMUM CUTOUT VOLTAGE	220 Vac	250 Vac	250 Vac	
MAXIMUM CURRENT	3A	2A	1A	
INSULATION RESISTANCE	10 ¹¹ Ohms			
TEMPERATURE	-40 °C +130 °C		[NY] -30 °C +130 °C [PP] -30 °C +60 °C	
MINIMUM DENSITY	e > 0,8 g/cm ³	e > 0,6 g/cm ³	[NY] e > 0,9 g/cm ³ [PP] e > 0,7 g/cm ³	
ASSEMBLY POSITION	Vertical ±15°	Vertical ± 30°	Vertical ± 15°	
PROTECTION CLASS	IP-65			

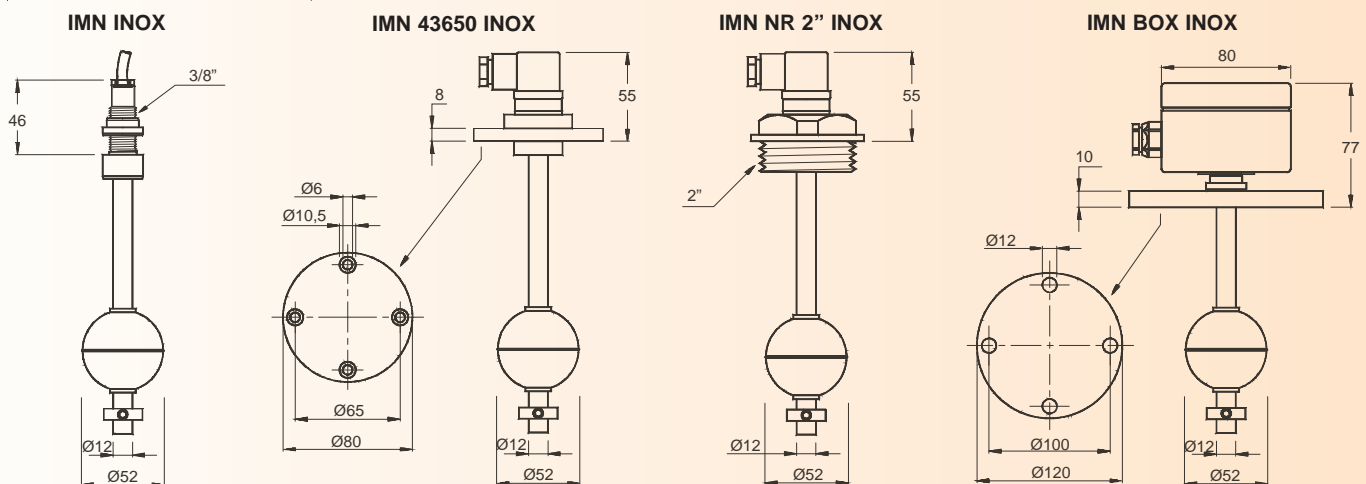

MAGNETIC LEVEL SWITCHES. MODELS AND PARTICULAR CHARACTERISTICS. SPECIAL MANUFACTURE

	IMN INOX	IMN 43650 INOX	IMN NR 2" INOX	IMN BOX INOX
ATTACHMENT	3/8" BSP S.S. AISI 316 connector	Stainless Steel AISI 316 flange	2" BSP S.S. AISI 316 threaded plug	PVC Flange
FLOAT	Type FEI - 1 Ø 52 mm AISI 316		Optional, types FCI-2, FCI-3, FEI-2	
CONNECTION	Cable: Silicone 130°C PVC 90°C - 1 m Long	DIN 43650 Connector		Aluminium connection box
Nº OF CONTACTS	Maximum 4 contacts	Maximum 2 contacts		Maximum 4 contacts
CONTACT TYPE	(NA) 80WVA/250Vac - 2A	(NC) 60WVA/220Vac - 2A	(NA/NC) 60WVA/220Vac - 2A	

Common characteristics to all models of special manufacture



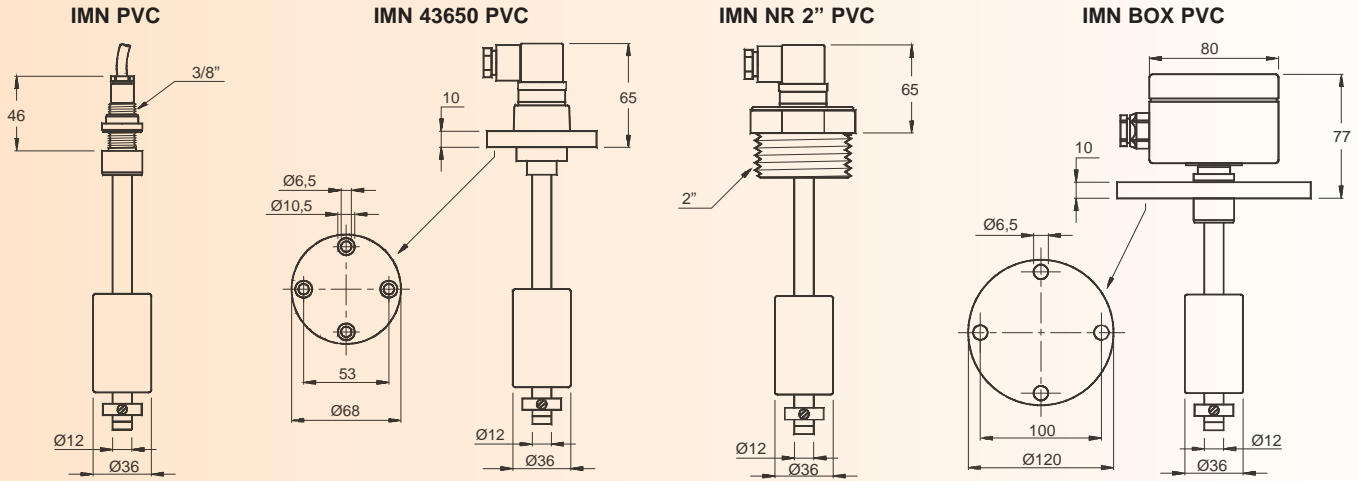

Table of chemical resistance to PVC and Polypropilene		
Product	Temperature °C	
	20	60
Bromic acid 50%	+	+
Hydrochloric acid	+	+
Hydrofluoric acid 48%	+	•
Oxalic acid 50%	+	•
Perchloric acid 10%	+	
Sulphuric acid 10%	+	+
Sulphuric acid 80%	+	+
Sulphuric acid 98%	+	•
Ammonic fluoride 20%	+	•
Calcic nitrate 50%	+	+
Photographics developers	+	

SIGNALS		
Unaltered	+	Do not resist •

MAGNETIC LEVEL SWITCHES. MODELS AND PARTICULAR CHARACTERISTICS. SPECIAL MANUFACTURE				
	IMN PVC	IMN 43650 PVC	IMN NR 2" PVC	IMN BOX PVC
ATTACHMENT	3/8" BSP PVC connector	PVC Flange	2" BSP PVC threaded plug	PVC Flange
FLOAT	Type FCP - 2, Ø36 x 61 mm, Polypropilene			
CONNECTION	Cable: PVC 90°C Long. 1 m	DIN 43650 Connector		ABS Connection box
Nº OF CONTACTS	Maximum 4 contacts	Maximum 3 contacts		Maximum 4 contacts
CONTACT TYPE	(NO) 80WVA/250Vac - 2A	(NC) 60WVA/220Vac - 2A		(NO/NC) 60WVA/220Vca - 2A

Common characteristics to all models of special manufacture

- Guide tube: Ø12 mm PVC
- Length: Min 100 mm - Max 3500 mm
- Distance between contacts: > 40 mm
- Temperature: -30 °C +60 °C
- Nominal pressure: 3 kg/cm³
- Minimum density: e>0,45 g/cm³
- Assembly position: Vertical ± 30°
- Protection class: IP65

NOTE: The data contained in the tables are understood to be without commitment and can be altered by factors like pressure, concentration etc.

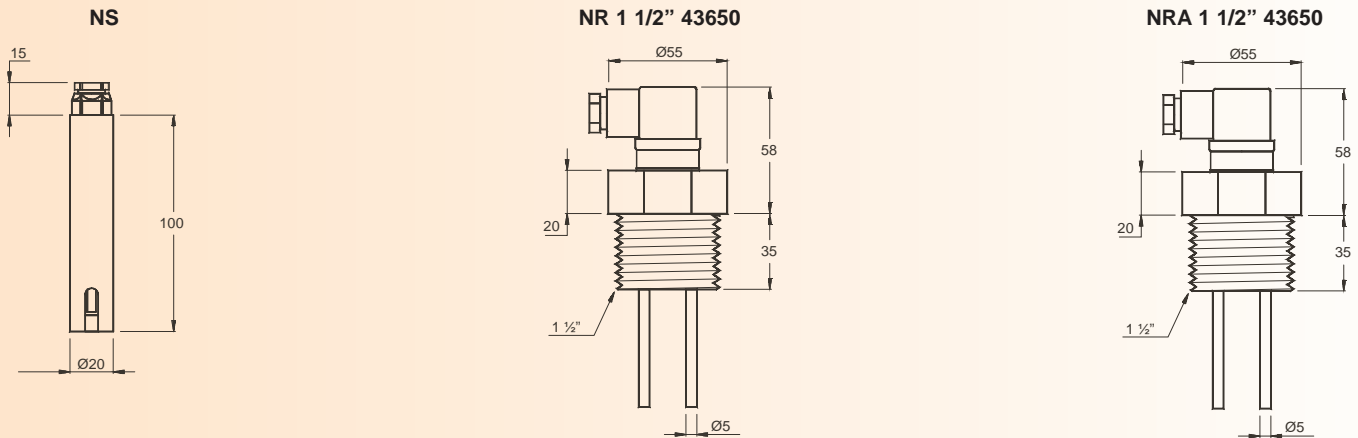

LEVEL CONTROLLERS FOR CONDUCTOR LIQUIDS, SOLIDS AND GRANULATES. GENERAL CHARACTERISTICS. STANDARD MODELS

	NS	NR 1 1/2" 43650	NRA 1 1/2" 43650
BODY MATERIAL	Grey Polypropilene	Red PVC	WhiteTeflon
ELECTRODE	Stainless Steel AISI 316	Stainless Steel AISI 316 Ø5 mm	
Nº ELECTRODES	1	From 1 to 4 electrodes	
ELECTRODE LENGTH	120 mm	1000 mm. Special lengths > 30 mm < 5000 mm	
ATTACHMENT	By cable	1 1/2" Connector	
CONNECTION	Screw terminal	DIN 43650 Connector	
MAXIMUM TEMPERATURE		+ 70°C	+ 140°C
PRESSURE		10 K/cm ² at +60°C	
ELECTRODE PROTECTION	---	Optional with PVC Ref: NR1 1/2	Optional with PTFE Ref: NRA1 1/2



Relay for level control in liquid, solid and granulate conductors, model PNSA

Dimensions

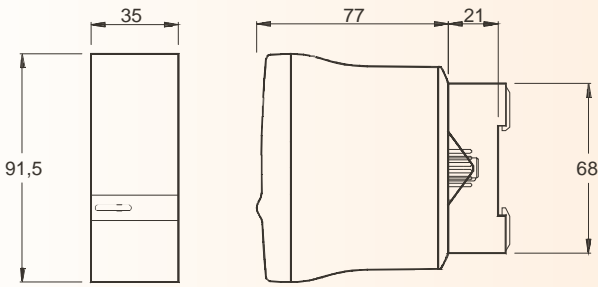

Power supply input

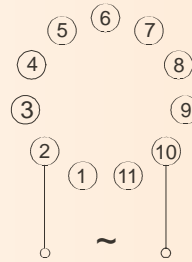

Technical data

Ac supply. Mode A

024	- 24Vca	50 / 60 Hz	+10 -15%
110	- 110Vca	50 / 60 Hz	+10 -15%
230	- 230Vca	50 / 60 Hz	+10 -15%
400	- 400Vca	50 / 60 Hz	+10 -15%
440	- 440Vca	50 / 60 Hz	+10 -15%

The transformer provides galvanic insulation between the supply voltage and the electronic circuit.

Other voltages available on demand

General characteristics

OPERATING PRINCIPLE CONNECTION	Control of maximum and minimum level The relay is activated when the liquid level reaches the maximum electrode level (5). It is deactivated when the liquid level drops below the minimum electrode level (6).
POWER SUPPLY	AC, Mode A
SENSITIVITY	Adjustable from 10 to 100 KΩ
VOLTAGE IN SENSOR	24 Vac
CURRENT IN SENSOR	4 mA (In shortcircuit)
CHARACTERISTICS OF THE SENSOR CABLE	Unshielded cables of section 1 to 2.5 mm ² with good insulation are usually used. In some installations, when the power and probe lines run parallel in the same tube over long distances, it is recommendable to use shielded cable. The resistance between cables and mass should be at least 200KΩ. The shield is connected to terminal 7, which corresponds to earth. Connection to mass: If the tank is not conductive, an additional probe should be installed for connection of mass, terminal 7.
LENGTH OF SENSOR CABLE	Unspecified
ACCESSORIES	Electrode models: NS, NR 43650, NRA 43650, NR, NRA, NT, NRP, NP, NRT2. Overvoltage protector PS-3 Separators NR.SEP Nuts NR.TUE/P 1 1/2".

Complements

Undecal base for relays of level control, model S3-B

Dimensions

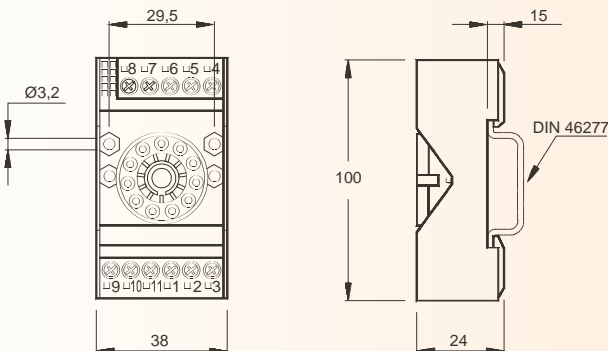

General characteristics

- **Undecal base:** 11 poles.
- **Borehole for screw:** M3
- **Box material and colour:** Noryl SE 100, light grey
- **Assembly:** DIN 46277 rail
- **Spring material:** Silver-plated brass
- **Accessory:** RB, relay-base coding ring

FIBER GLASS COVERED WITH A SILICONE RUBBER LAYER INSULATING SHEATHS, MODELS TU-FIVISI

General characteristics

- Plaited glass fibre protection covered with a silicon rubber layer.
- Continuous working temperature: from -60 °C to +250 °C. Peaks up to +290 °C.
- Adequate resistance to humidity, ozone and UV.
- Adequate resistance to most chemical atmospheres.
- Auto-extinguished
- Dry dielectrical strength from: **1,5 to 2 kV.**

Packaging: In coils of 50 or 100 m. according to stock.

Usual applications

- Internal wires for revolving machinery (Class H and C)
- All kind of insulators continuously reaching 250°C in electrical pipes
- Heating elements
- Lighting items
- Measuring and regulating
- Pipe connections
- Thermal insulation of wire handles

Code	Reference	Colour and temperature range	Dimensions in mm		Weight kg/km
			Øint + Tolerance	Wall thickness	
116030000	TU-FIVISI-1	RED BRICK -60 °C at +250 °C	1 ± 0,20	0,15 - 0,60	3,8
116030100	TU-FIVISI-2		2 ± 0,20	0,15 - 0,65	5
116030200	TU-FIVISI-3		3 ± 0,20	0,15 - 0,65	7,7
116030300	TU-FIVISI-4		4 ± 0,25	0,20 - 0,65	13,2
116030400	TU-FIVISI-5		5 ± 0,25	0,20 - 0,65	15
116030500	TU-FIVISI-6		6 ± 0,25	0,20 - 0,65	16,5
116030600	TU-FIVISI-8		8 ± 0,25	0,20 - 0,80	25
116030700	TU-FIVISI-10		10 ± 0,50	0,40 - 1,00	34
116031200	TU-FIVISI-12		12 ± 0,50	0,40 - 1,20	45

FIBER GLASS IMPREGNATED WITH PURE SILICONE GLAZE, MODELS TU-FIVI

General characteristics

- Plaited glass fibre protection fully impregnated with a pure silicon glaze.
- Continuous working temperature: from -60 °C to +350 °C. Peaks up to +400 °C.
- Adequate mechanical resistance.
- Incombustible.
- Dry dielectrical strength from: **0,8 to 1,2 kV.**

Packaging: In coils of 50 or 100 m. according to stock.

Usual applications

- Heating elements
- Heating wires for electrodomestic items
- Electrothermal machinery
- Cookers, etc.

Code	Reference	Colour and temperature range	Dimensions en mm		Weight kg/km
			Øint + Tolerance	Wall thickness	
116020000	TU-FVI-1	NATURAL WHITE -60 °C at +350 °C	1 ± 0,25	0,35	2,4
116020200	TU-FVI-2		2 ± 0,25	0,4	3,1
116020100	TU-FVI-2,5		2,5 ± 0,25	0,4	3,9
116020300	TU-FVI-3		3 ± 0,25	0,4	6,8
116020400	TU-FVI-4		4 ± 0,30	0,5	9
116020500	TU-FVI-5		5 ± 0,30	0,5	11
116020600	TU-FVI-6		6 ± 0,30	0,5	12
116020700	TU-FVI-8		8 ± 0,40	0,5	16
116020800	TU-FVI-10		10 ± 0,50	0,6	20
116020900	TU-FVI-12		12 ± 1,00	0,7	29
116021100	TU-FVI-16		16 ± 1,00	0,9	49

PLAITED PROTECTION OF SILICON FIBRE, NOT TREATED, NON IMPREGNATED, MODELS TU-SILICIO

General characteristics

- Continuous working temperature: + 1050°C. Peaks up to + 1200°C.
- Incombustible.
- Good flexibility.
- Excellent thermal insulation properties.
- Low thermal dilatation coefficient.
- Slight fraying at cut.
- Very high chemical resistance, specially towards acids.

Chemical composition

- Silica dioxide SiO₂ > 99,9%
- **PRODUCT GUARANTEED WITHOUT ASBESTOS.**

Usual applications

- Protection of rollers to transport annealing ovens for special glasses (does not modify the surface of the glass plates).
- High temperature insulating handle protection.
- Industrial ovens.

Code	Reference	Colour and temperature range	Dimensions in mm		Weight kg/km
			Øinternal	Wall thickness	
116035000	TU-SILICIO-1	NATURAL WHITE +1050 °C	1	0,7	3,8
116035100	TU-SILICIO-2		2	0,7	6,2
116035300	TU-SILICIO-4		4	0,7	15,2
116035500	TU-SILICIO-6		6	0,7	24

FMINERAL FIBRE PROTECTION COATED IN SILICONE RUBBER, WATER AND FIRE PROOF, MODELS TU-FIMINSI

General characteristics

- Continuous work temperature: from -60 °C to +260 °C.
- Peaks: 30 min at 800 °C / 15 min at 1100 °C / 1 min at 1500 °C
- Excellent flexibility at low temperature.
- Slight swelling with hydrocarbons.
- Does not harden, soften or flake.
- The plait thickness ensures thermal protection.
- The silicone layer ensures resistance to occasional flames and water and reinforces the thermal efficiency.
- **PRODUCT GUARANTEED WITHOUT ASBESTOS**

Usual applications

- Iron and steel industry, glass industry, chemical industry, naval and rail construction. Protection and insulation of electrical wire handles, water, gas, compressed air, hydraulic fluids pipes against several types of aggression:
- Presence of flames.
- Melted metal or glass projections.
- Steam projections... aeronautic and space construction. All aggressive environments (flames, projections, etc)

Standards

- Inspired by the American aeronautic norm SAE 1072

Code	Reference	Colour and temperature range	Dimensions in mm		Weight kg/km
			Øinternal	Wall thickness	
116040800	TU-FIMINSI-10	RED BRICK -60 °C at +260 °C	10	4	140



GROUP 12- Electrical cable and insulating sheaths

12.2 - Fiber glass covered electrical nickel cable

General characteristics

- Continuous working temperatures: -60 °C to +350 °C. Peaks at +400 °C.
- Adequate resistance to thermal shock and UV.
- Excellent ageing resistance.
- Adequate resistance to humidity

Electrical characteristics

- Working voltage: **500 V**
- Test voltage: **2000 V**.
- Dielectrical strength: **2500 V**.

Usual applications

- Wiring of heating elements
- Domestic electrical heating appliances
- Commercial cookers and ovens
- Machines for thermoplastics or rubber, etc.

Packaging: In coils of 25, 50 or 100 m according to stock.

Code	Colour	Section mm ²	Ø external mm	Nº Leads	Ø Lead mm	Weight kg/km	Max current at 320°C Amp.
119057009	WHITE	0,25	1,9	4	0,3	6,5	1,5
119010001	BROWN						
119010006	BLACK	0,5	2,2	7	0,3	8,7	2
119010009	WHITE						
119012001	BROWN	0,75	2,4	11	0,3	11,9	4,5
119012009	WHITE						
119008002	RED						
119008009	WHITE	1	2,5	14	0,3	14,5	5,5
119056007	GREEN+YELLOW (EARTH CONNECTION)						
119013001	BROWN	1,5	2,7	21	0,3	20,5	7
119013012	VIOLET						
119011011	ORANGE	2,5	3,2	35	0,3	32,2	10
119009003	BLUE	4	4	56	0,3	50,1	13,5
119046006	BLACK	6	4,6	84	0,3	72,3	16

GROUP 12- Electrical cable and insulating sheaths

12.3 - Silicone covered electrical copper cable

General characteristics

- Continuous work temperature: from -60°C to +180°C. Peaks up to +230°C.
- Adequate resistance to thermal shocks and to UV
- Excellent ageing resistance.
- Flexible red copper nucleus.
- Silicone rubber type EI2 - HD 22.1.

Electrical characteristics

- Working voltage: **500 V**
- Test voltage: **2000 V**.

Usual applications

- Heating wires for electrodomeestic items
- Revolving machinery (Class H)
- Lighting items
- Industrial wires in hot atmospheres, etc.

Packaging: In coils of 100 or 200 m according to stock.

Code	Colour	Section mm ²	Ø external mm	Nº Leads	Ø Lead mm	Weight kg/km	Max. linear resistance at 20 °C W/km
119001009	WHITE	0,75	2,3	24	0,2	11,5	< 26
119002009	WHITE	1	2,5	32	0,2	14,2	< 19,5
119056003	BLUE						
119056005	RED BRICK	1,5	2,8	30	0,25	19,8	< 13,3
119056009	WHITE						
119004003	BLUE						
119004005	RED BRICK	2,5	3,4	50	0,25	30,7	< 7,98
119004009	WHITE						
119005001	BROWN						
119005006	BLACK	4	4,2	56	0,3	48	< 4,95
119005009	WHITE						
119006001	BROWN						
119006005	RED BRICK	6	5,2	84	0,3	72,8	< 3,30
119006006	BLACK						

GROUP 13- Limescale control and cold production

13.1 - Magnetic anti-calcium that reduces corrosion

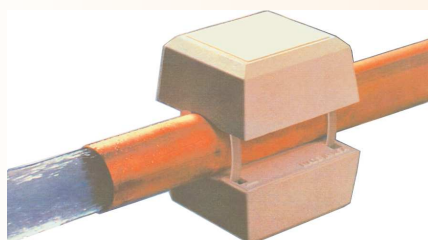

This is a revolutionary system for the conditioning of drinking water. By means of a magnetic field, it reduces the sedimentation speed of the calcium contained in water and changes the type of crystalline structure while reducing the thickness and type of calcium deposited on resistors, tubing, tap sprayers, hand-held shower heads, etc., keeping the passage of water clear and diminishing the effects of interstitial corrosion caused by calcium sediments.

Model	Code
STANDARD FOR PIPES (In blister pack)	575005000

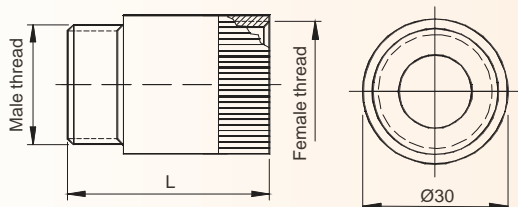

Model	Code	BSP Thread		L in mm
		Male	Female	
FOR SHOWERS	575002000	R 1/2"	R 1/2"	42
FOR WASHING MACHINES	575003000	R 3/4"	R 3/4"	44
FOR DISHWASHER	575004000	R 3/4"	R 3/4"	44

The **STANDARD** Magnetic Anti-Calcium Systems are for installation on the outside of copper, iron, plastic and other types of pipes. The pipe does not need to be cut and the water flow need not be interrupted. The installation may be performed manually without the help of tools. The benefits of the magnetic field are effective within an area of approximately 30 meters from the installation point. If a pump is installed on the line, the effect disappears, so another unit must be installed at the discharge of the pump.

If this product is installed at the water intake, corrosion is reduced. While corrosion is not completely eliminated for some types of water, in most cases the service life of resistors, tanks and pipes is effectively extended.

The **SHOWER** model is for installation between the outlet thread of the tap and the hand-held shower head thread, and in the other two models (**WASHING MACHINE** and **DISHWASHER**), between the outlet thread of the tap and the hose thread of the washing machine or dishwasher.

NOTE: Nowadays it is fashionable to magnetize water for therapeutic and other uses. ELECTRICFOR only has equipment to verify the improvement with respect to corrosion and reduction of calcium sediments, so we cannot provide advice on other applications. To determine the effect of this product on other characteristics of water, we recommend that a specialized technical expert be contacted.



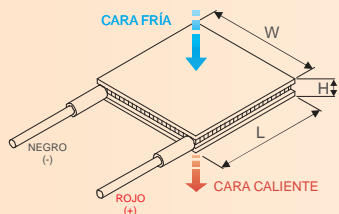

What is Thermoelectricity?

Thermoelectricity studies the behaviour of semiconductors that act as solid state heat pumps. It enables small surfaces to be cooled extremely accurately, up to 0.001 °C. The temperature difference between cell faces can reach up to 130 °C and work from 0.8 Vcc up to 15.4 Vcc; and from 0.8 A up to 20 A, at all times in continuous current.

Operating principle

A TEC is a thermoelectric device that converts electric energy into calorific energy.

The TEC's operating principle is the Peltier effect described by Jean Charles Athanase Peltier in 1834, which is when a current flows through two different material conductors and heat is generated or absorbed at the junction of the materials, depending on the value and sign of the current and the joining materials.

Each of these junctions receives the name thermocouple, and is most commonly used for measuring temperatures.

The Peltier cell, TEC, is a set of thermocouples located electrically in series and technically in parallel, so that all the thermocouples that are absorbing heat are on one side of the plate and those that give it off are on the other.

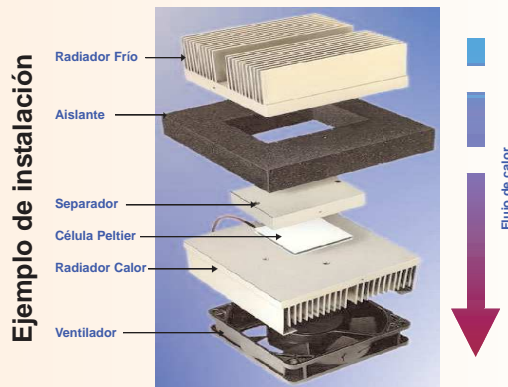
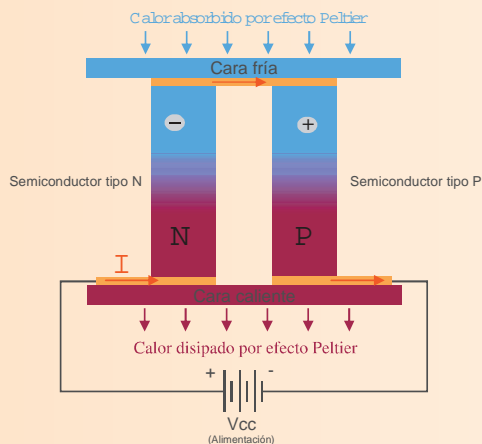

Standard Models

Model	Test Ambiance Temp.= 27 °C Max. Working temp. = 125 °C				Dimensions in mm		
	Junction	Imax	Vmax	Qmax (W) ΔT = 67 °C	L	W	H
TEC 1-00 703 T1 25	7	3	0,8	1,6	10	10	5,4
TEC 1-00 705 T1 25	7	5	0,8	2,6	10	10	4,2
TEC 1-00 707 T1 25	7	7	0,8	3,6	10	10	3,7
TEC 1-00 712 T1 25	7	12	0,8	6,2	10	10	3,2
TEC 1-01 703 T1 25	17	3	2,0	3,8	15	15	5,4
TEC 1-01 705 T1 25	17	5	2,0	6,3	15	15	4,2
TEC 1-01 707 T1 25	17	7	2,0	8,8	15	15	3,7
TEC 1-01 712 T1 25	17	12	2,0	15,1	15	15	3,2
TEC 1-02 303 T1 25	23	3	2,8	5,1	15	20	5,4
TEC 1-02 305 T1 25	23	5	2,8	8,5	15	20	4,2
TEC 1-02 307 T1 25	23	7	2,8	11,9	15	20	3,7
TEC 1-02 312 T1 25	23	12	2,8	20,5	15	20	3,2
TEC 1-03 503 T1 25	35	3	4,2	7,8	15	30	5,4
TEC 1-03 505 T1 25	35	5	4,2	13,0	15	30	4,2
TEC 1-03 507 T1 25	35	7	4,2	18,2	15	30	3,7
TEC 1-03 512 T1 25	35	12	4,2	31,2	15	30	3,2
TEC 1-04 703 T1 25	47	3	5,6	10,5	30	30	5,4
TEC 1-04 705 T1 25	47	5	5,6	17,4	30	30	4,2
TEC 1-04 707 T1 25	47	7	5,6	24,4	30	30	3,7
TEC 1-04 712 T1 25	47	12	5,6	41,8	30	30	3,2
TEC 1-07 103 T1 25	71	3	8,5	15,8	30	30	5,4
TEC 1-07 105 T1 25	71	5	8,5	26,3	30	30	4,2
TEC 1-07 107 T1 25	71	7	8,5	36,9	30	30	3,7
TEC 1-07 112 T1 25	71	12	8,5	63,2	30	30	3,2
TEC 1-09 503 T1 25	95	3	11,4	21,1	30	40	5,4
TEC 1-09 505 T1 25	95	5	11,4	35,2	30	40	4,2
TEC 1-09 507 T1 25	95	7	11,4	49,3	30	40	3,7
TEC 1-09 512 T1 25	95	12	11,4	84,6	30	40	3,2

Model	Test Ambiance Temp.= 27 °C Max. Working temp. = 125 °C				Dimensions in mm		
	Junction	Imax	Vmax	Qmax (W) ΔT = 67 °C	L	W	H
(*) TEC 1-12 703 T1 25	127	3	15,2	28,3	40	40	5,4
(*) TEC 1-12 704 T1 25	127	4	15,2	37,7	40	40	4,7
(*) TEC 1-12 705 T1 25	127	5	15,2	47,1	40	40	4,2
TEC 1-12 707 T1 25	127	7	15,2	65,9	40	40	3,7
TEC 1-12 712 T1 25	127	12	15,2	113,0	40	40	3,2
TEC 1-16 103 T1 25	161	3	19,3	35,8	45	45	5,4
TEC 1-16 105 T1 25	161	5	19,3	59,7	45	45	4,2
TEC 1-16 107 T1 25	161	7	19,3	83,6	45	45	3,7
TEC 1-16 112 T1 25	161	12	19,3	143,3	45	45	3,2
TEC 1-07 108 T1 25	71	8	8,5	42,1	38	38	4,6
TEC 1-07 118 T1 25	71	18	8,5	94,8	38	38	3,4
(*) TEC 1-12 708 T1 25	127	8	15,2	75,4	50	50	4,6
TEC 1-12 718 T1 25	127	18	15,2	169,6	50	50	3,4
TEC 1-03 102 T1 25	31	2	3,7	4,6	15	15	4,4
TEC 1-03 104 T1 25	31	4	3,7	9,2	15	15	3,1
TEC 1-04 702 T1 25	47	2	5,6	7,0	15	23	4,4
TEC 1-04 704 T1 25	47	4	5,6	13,9	15	23	3,1
TEC 1-06 302 T1 25	63	2	7,6	9,4	15	30	4,4
TEC 1-06 304 T1 25	63	4	7,6	18,7	15	30	3,1
TEC 1-07 102 T1 25	71	2	8,5	10,5	23	23	4,4
TEC 1-07 104 T1 25	71	4	8,5	21,1	23	23	3,1
(*) TES 1-127 03 T1 25	127	3	15,2	28,3	30	30	3,5
(*) TES 1-127 04 T1 25	127	4	15,2	37,7	30	30	3,1

(*) - Models in stock permanently

As well as Peltier cells, we can also offer a wide range of "Heat Pipe" models. Please refer to our Sales Department.



Electric panels and infrared radiation heating screens by Electricfor will provide the most efficient additional heat to your litter of piglets.

Heating for suckling piglets in pig breeding farms is a concern for producers as piglets are vulnerable to temperature changes. In the past, the air temperature had to be kept high, which meant significant heat losses as the air had to be constantly reheated, resulting in huge energy expenses.

Nowadays two heating systems are mainly used for animal breeding: electric panels and infrared heating lamps, which can not only enhance the sow and piglets' comfort, but will also save energy and increase productivity.

Electricfor's electric heating panels have been designed to provide supplementary heat for suckling and weaned pigs. They provide a comfortable area for the piglets to rest, away from the sow, thus avoiding losses from squashing. At the same time, the heating panels block out cold air currents coming from the pit.

Advantages

- Reduces losses from squashing.
- Prevents diseases.
- Increase weight of the weaned piglet.
- Long-lasting.
- Reduces energy costs

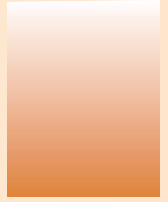

General features:

- Manufactured in polyester fibre with long-lasting resin coating, appropriate for use in adverse environmental conditions.
- Completely water and damp-proof. IP-55 protection.
- Insulated heating element. Models available in Class I and Class II .
- Even heat distribution.
- Power divided into two areas, evenly split over the whole surface area whatever the chosen power.
- Non-slip markings on the whole surface on both sides.
- With an accessory, possibility of providing a slight inclination to the plate.
- Possibility of optimising power consumption by connecting an energy regulator (infinite), an electronic power regulator or using a switch to select different types of connection. See Accessories for electric heater plates and infrared radiation heating screens.
- Input hose cable with neoprene cover 3x1 mm², 2000mm long
- 230 Vac - 125 W (62.5 + 62.5 W)



Code		Dimensions		Useful for	Maximum Power	energy consumed (KW·h / day / litter)	
		meters	feet				
PCG001	(Class I)	1,2 x 0,41	3.94 x 1.35	During the breastfed	From 8 to 10 piglets (per side)	62.5 W + 62.5 W	1.5
PCG002	(Class II)	1,2 x 0,41	3.94 x 1.35	During rest	From 14 to 18 piglets (per side)	62.5 W + 62.5 W	1.5

ACCPCG Accessory support to provide a slight tilt to the heater panel, allowing a better position sucker for the breastfed

Connection possibilities and corresponding powers

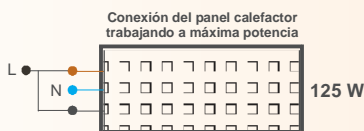

A bridge is made between the black and red cables and it is connected to the phase. The blue cable is connected to the neutral.

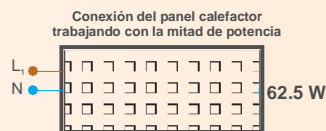

The red or black cables are connected to phases and the blue cable to the neutral.



The red and black cables are connected to the phase and neutral. The blue cable is not connected.

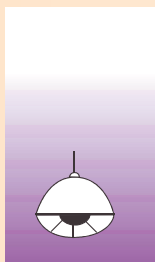

Advantages

The infrared radiation heating screens are a versatile and low cost source of heat for current breeding practices.

. When you want to heat a specific surface, that is, when you want to provide partial heat, rather than central or global heat, the infrared lamp produces the optimum heating effect. For example, in pig farms where the sows and piglets are together, infrared lamps are principally used to keep the piglets warm. The lamps' infrared rays pass through the air without heating it, just like the sun's energy. When these rays reach the animal, the absorbed energy is converted into heat.

If the lamps are mounted at an appropriate height a "comfort zone" is created where the piglets can move about freely and find the level of heat they want.

Experience and research has shown that infrared heating screens can save an average of 1-2 piglets per litter by preventing death from cold, which is so common after birth in winter months. Many farmers use this equipment as they are easy to install and are long-lasting. They are also portable, so they can be used for other purposes.

Models with infrared heater element in stainless steel

The first 12 to 24 hours after birth is a critical time for newborn animals, especially pigs. During this time it is often a good idea to use two 300 watt screens- one in the birthing area and the other in the nursing area. After 24 hours, one of the screens can be moved to provide a warm area in the rest area.

General features

- Heating element in stainless steel AISI 321, Ø6.4mm.
- IP-55 humidity protection.
- Input hose cable 1500mm long, finished with Schuco type connector of 16 A.
- Reflective screen in brushed aluminium of Ø210x140 mm.

Code	Voltage supply	Watts	Dimensions in mm
PIG030	~230 V	300 W	Ø275 x 135



Models with ceramic infrared heating element

With a robust design, its infrared emission spectrum ranges between 2 - 10 μm. It can be connected through an E27 ceramic cap. It is usually installed in a reflective screen (see accessories for infrared screens and heating plates).

Code	Voltage supply	Watts	Dimensions in mm
(*) PICG60	~230 V	60 W	Ø80x110
(*) PICG100	~230 V	100 W	Ø80x110
(*) PICG150	~230 V	150 W	Ø95x140
PICG250	~230 V	250 W	Ø95x140



(*) Models recommended for this application

Accessories for electric panels and infrared radiation heating screens

Code	Description
HBOS	Ceramic holder E27
PBOSP	reflective screen Ø210x140 mm
BOS60	Spare heating element for PICG60. 230 V – 60 W
BOS100	Spare heating element for PICG100. 230 V – 100 W
BOS150	Spare heating element for PICG150. 230 V – 150 W
BOS250	Spare heating element for PICG250. 230 V – 250 W
IGRR Ø30	Spare heating element for PIG030. 230 V – 300 W



For energy consumption optimisation there is the possibility of connecting devices

to the electric heating plates and the infrared radiation heating screens that regulate energy (or simmerstat), as well as power regulators.

An infinite energy regulator or simmerstat is an electric control element that enables the user to select the on and off cycles. The regulator button enables you to determine what proportion of cycles goes on and off. For example, with the control device turned at 1/4 you have a working cycle of 5 seconds on and 15 seconds off, giving approximately 35% of the total power of the heating element.

The power regulators are devices that enable you to select the % of power with which you wish to work. A scale button from 1 to 10 enables you to select the power with which the heating element will work (1 is 10% - 10 is 100%).



Code	Description	
517230000	Energy regulator (simmerstat)	~200 / 240 V – 13 A
517230001	White button for energy regulator	
517192000	Energy regulators based on triacs	Current: 2 A – 230 V – 440 W



SELF-ADHESIVE DE-MISTING ELEMENTS FOR MIRRORS, MODELS STOP VAPOR



StopVapor is the final effective solution for solving the problem of misting on the mirror after showers. It prevents the mirror from misting-up, so that you can see yourself immediately perfectly!

Very easy to install, StopVapor is a self-adhesive heating foil to be attached to the back of the mirror in the position you require.

You need to leave 1 cm between the wall and the mirror to allow the cable to pass through.

StopVapor is an interesting accessory which will complete your assortment of bathroom articles, adding innovation and quality.

StopVapor has been designed fully respecting the European safety regulations (EN 60335) and the CE regulation mark

Code	Description	Volts	Watts	Dimensions in mm
E09112	De-misting heater STOPVAPOR-P	~230 V	8 W	165 x 280
E09113	De-misting heater STOPVAPOR-M	~230 V	16 W	280 x 280
E09114	De-misting heater STOPVAPOR-G	~230 V	24 W	410 x 280
E09116	De-misting heater STOPVAPOR-C	~230 V	55 W	500 x 500
E09115	De-misting heater STOPVAPOR-R	~230 V	95 W	1010 x 440

GROUP 16- Heaters and accessories for aquariums, terrariums and gardens

ULTRA-THIN EXTERNAL HEATING PAD, MODELS TERRA

Undertank heating pad for terrariums which guarantees a safe heating system for a suitable environmental temperature to most reptiles, amphibians and small animals.

It has a low energy consumption, as opposed to incandescent lamps, and it represents the ideal way to provide an evenly distributed heat. The heating pad allows also the creation of a cooler area for your animals because it is installed on the bottom, unlike other heating systems.

Easy to install, the heating pad is ultra-flat and thin.

Placed outside the tank, it is totally safe for your animals. Sure and reliable even for the user because there are no electrical wires within the heating pad.

Code	Description	Volts	Watts	Dimensions in mm
E09100	Heating pad TERRA-S	~230 V	8 W	165 x 280
E09101	Heating pad TERRA-M	~230 V	16 W	285 x 280
E09102	Heating pad TERRA-G	~230 V	24 W	410 x 280

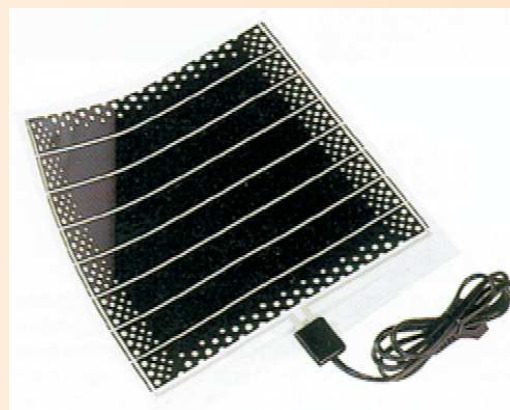

Definitions

- Load density:** Power emitted in watts per surface unit in a heater. It indicates the potential of a surface to transmit caloric energy and is expressed in W/cm².
- Heat radiation:** Process of emitting energy radiating in the form of waves. Infrared is an area of the electromagnetic spectrum with a range of 1 to 1000 microns.
- Heat:** Heat is the energy necessary to change the temperature of a body.
- Heat conduction:** Method of heat transfer by direct contact of bodies in which there is a temperature difference between the two.
- Heat convection:** Method of heat transfer linked to conduction, in which the heat is transferred from an area of higher temperature to another area of lower temperature as a result of moving masses of transmitting fluid.
- Dielectric strength:** Voltage applied to the insulating material without an electrical fault occurring. In Class I heating-component tests, a strength test of 1,250 V is performed for 1 minute between active parts and shielding. (EN 60335-1)
- Leakage current:** Electrical current between any pole of the power supply and the accessible metal parts of the apparatuses. In the heating devices, the leakage current must not be greater than 0.75 mA per kW with a maximum of 5 mA for the entire device (EN 60335-1)

Conversion factors

1 KJ	=	0,24	KCal
1 W	=	1	J/seg
1 Kcal	=	0,00116	KWh
1 KJ	=	0,948	BTU
1 W	=	3,412	BTU/h
1 KJ/Kg	=	0,423	BTU/lb
1 KJ/Kg°C	=	0,24	BTU/lb°F
1 cm	=	0,3937	in
1 Kg	=	2,205	lb
1 W/cm ²	=	6,45	W/in ²

1 KCal	=	4,18	KJ
1 J/seg	=	1	W
1 KWh	=	861,24	Kcal
1 BTU	=	1,055	KJ
1 BTU/h	=	0,2931	W
1 BTU/lb	=	2,326	KJ/Kg
1 BTU/lb°F	=	4,18	KJ/Kg°C
1 in	=	2,54	cm
1 lb	=	0,4536	Kg
1 W/in ²	=	0,155	W/cm

Temperature conversion. Formulas

°C = Degrees centigrade

°F = Degrees fahrenheit

K = Kelvins

$$°F = 1.8°C + 32$$

$$°C = (°F - 32) \times 5/9$$

$$K = °C + 273$$

Physical properties of the materials

Material	Density (Kg/dm ³)	Specific heat (KJ/Kg°C)	Haet of fusion (KJ/Kg)	Latent heat of vaporisation (KJ/Kg)
Oil	0,9	1,8	–	293
Water	1	4,18	–	2250
Air	0,0013	1	–	–
Aluminium	2,6	0,9	296	8350
Copper	8,92	0,39	181	7379
Tin	7,31	0,23	59	2739
Iron	7,8	0,44	272	6365
Paraffin	0,89	2,93	147	–
Petroleum	0,93	1,8	–	–
Soda (NaOH 18%)	1,2	3,5	–	1693
Trichloethylene	1,47	0,93	96	24



Determining the caloric power.

General method to determine the caloric power.

1.- Establish the reference data:

- Minimum initial temperature and maximum final temperature: ΔT
- Flow rate or maximum volume of material to be heated.
- Time required for heating process.
- Dimensions of the receptacle or duct.
- Insulation and its properties.
- Electrical data: voltage and electrical limitations.
- Control elements: temperature, power, level, intensity, etc.

2.- Calculate the necessary caloric power. (See Formulas)

3.- System factors that may influence the choice of the heating component.

- Working temperature.
- Maximum admissible load density.
- Mechanical considerations.
- Environmental factors.
- Safety factors.

4.- Selecting the heating component.

- Type, size, and quantity.

5.- Selecting the control and safety components.

- Type and positioning.

Formulas

$$P_T = (P_A + P_B + P_C) \times F_S$$

P_A = Power necessary to increase the temperature of the material in the desired time.

P_B = Power necessary to melt or vaporise the material in the desired time.

P_C = Heat losses through the surface.

F_S = Safety factor. Normally between 10% and 30% depending on the application.

$$P_A \text{ (KW)} = \frac{\text{Mass (Kg)} \times \text{Specific heat (KJ/Kg } ^\circ\text{C)} \times \Delta T \text{ (} ^\circ\text{C)}}{\text{Heating time (sec)}}$$

$$P_B \text{ (KW)} = \frac{\text{Mass (Kg)} \times \text{Latent heat of fusion or vaporisation (KJ/Kg)}}{\text{Heating time (sec)}}$$

$$P_C \text{ (W)} = \frac{\text{Heat conductivity (W/m} ^\circ\text{C)} \times \text{Surface area (m}^2\text{)} \times \Delta T \text{ (} ^\circ\text{C)}}{\text{Insulation thickness (m)}}$$

Ohm's Law

Definition: The potential difference between two points of a conductor is equal to the product of the current multiplied by the resistance of a conductor.

$$V = I \times R$$

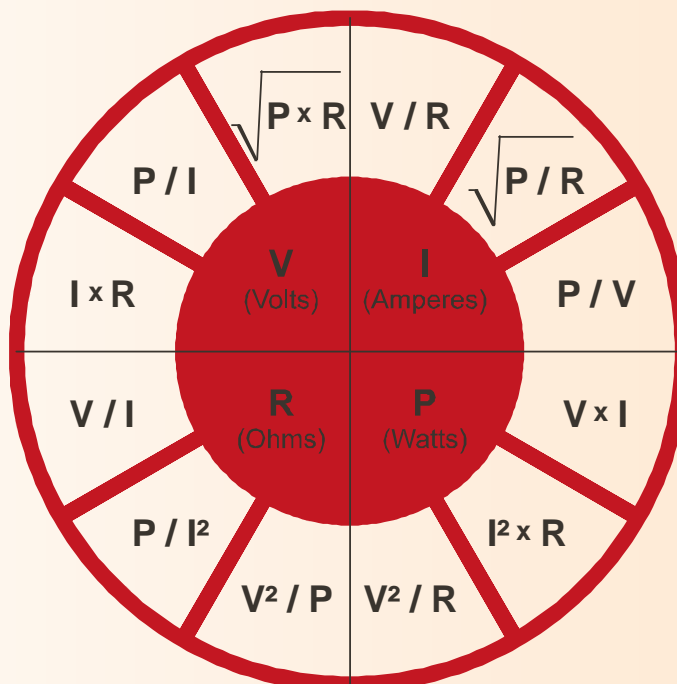

Linking of resistors

Linking in series

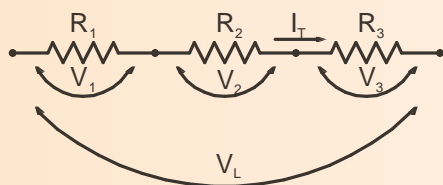

Formulas

Linking of resistor series

$$R_{eq} = R_1 + R_2 + R_3$$

$$I_T = I_1 = I_2 = I_3 = V_T / R_{eq}$$

$$V_T = V_1 + V_2 + V_3$$

$$P_T = (V_T)^2 / R_{eq} = V_T \times I_T$$

$$P_n = (P_T / V_T)^2 \times R_n$$

Legend

- P_T = Total circuit power
- $P_1 / P_2 / P_3$ = Power of each resistor
- V_L = Line voltage
- $V_1 / V_2 / V_3$ = Resistor terminals voltage

Three-phase circuits (balanced circuits)

Star

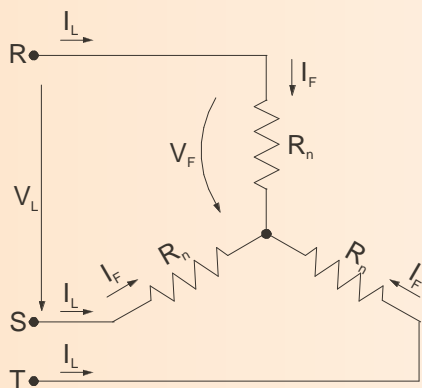

Formulas

Star

$$I_L = I_F$$

$$V_F = V_L / \sqrt{3}$$

$$P_T = (V_L)^2 / R_n = V_L \times I_L \times \sqrt{3}$$

$$P_n = (V_F)^2 / R_n$$

Legend

- P_T = Total circuit power
- P_n = Power of each branch
- V_L = (Line voltage (between phases))
- V_F = Resistor terminals voltage

Linking in parallel

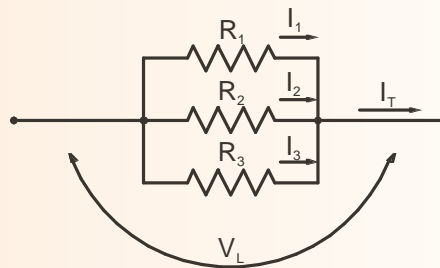

Linking of resistors in parallel

$$(1 / R_{eq}) = (1 / R_1) + (1 / R_2) + (1 / R_3)$$

$$I_T = I_1 + I_2 + I_3$$

$$V_T = V_1 = V_2 = V_3 = I_T \times R_{eq}$$

$$P_T = (V_T)^2 / R_{eq} = V_T \times I_T$$

$$P_n = (P_T / V_T)^2 \times R_n$$

- R_{eq} = Total resistive value of circuit
- $R_1 / R_2 / R_3$ = Resistors
- I_T = Total circuit current
- $I_1 / I_2 / I_3$ = Current through each resistor

Triangle

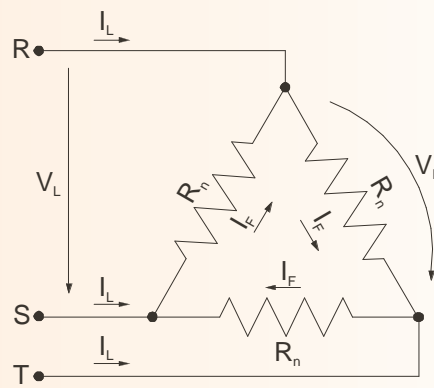

Triangle

$$I_F = I_L / \sqrt{3}$$

$$V_L = V_F$$

$$P_T = 3 \times (V_L)^2 / R_n = V_L \times I_L \times \sqrt{3}$$

$$P_n = (V_F)^2 / R_n$$

- R_n = Resistors
- I_L = Line current
- I_F = Current through each branch

